



产品规格书

PRODUCT SPECIFICATION

客户名称 CUSTOMER: _____

产品型号 MODEL: MLT-5030

客户型号 USER'S MODEL: _____

日期 DATE: 2021-3-12

江苏华能电子有限公司			客户回签		
HUAWHA			CUSTOMER		
SERVE RATITY			CUSTOMER RATIGY		
拟制	审核	批准	检验	审核	批准
REPORT	CHECKED	APPROVED	TEST	CHECKED	APPROVED
王文娟	工稿用章	张长华			

江苏华能电子有限公司

JIANGSU HUAWHA ELECTRONICS CO.,LTD

地址：江苏省泰州市兴化市陈堡镇工业园区

ADD:Chenbao Industrial Park, Chenbao Town, Xinghua,Taizhou City, Jiangsu China.

电话 TEL:0523-83710666 传真 FAX:0523-83724866

网址: www.huawha.com 邮箱: hndz_wwj@huawha.com

1.基本规格/General specification

项目/Item		规格/Spec	条件/Condition
1	额定电压 Rated voltage	3.0Vo-p	
2	工作电压 Operation voltage	2~4Vo-p	
3	声压 Sound Pressure Level=SPL	$\geq 80\text{dB}$	测试环境：标准状态，标准驱动电路， 额定电压 测试距离：0.1m Standard State,Standard Drive Circuit. Rated voltage,Distance at 0.1m
4	电流 current	Max100mA	
	阻抗 Coil Resistance	$12 \pm 3 \Omega$	
5	振荡频率 Oscillation frequency	4000Hz	
6	工作温度范围 Operating Temperature	-20~+70℃	声压 $\geq 80\text{dB}$ SPL $\geq 80\text{dB}$
7	保存温度范围 Storage temperature	-40~+85℃	
8	外部尺寸 Externals size (mm)	5.2*5.2*3	参阅附图 Refer to the attached drawing
9	重量 Mass	0.3g	
10	材质 Housing Material	LCP	

2.电气和声学测试条件/Electrical And Acoustical Measuring Condition

驱动电路/Recommended Driving Circuit

设置 Recommended Setting

Resonant frequency, 1/2 duty cycle. Square wave.
 Signal amplitude should be large enough to saturate the transistor.

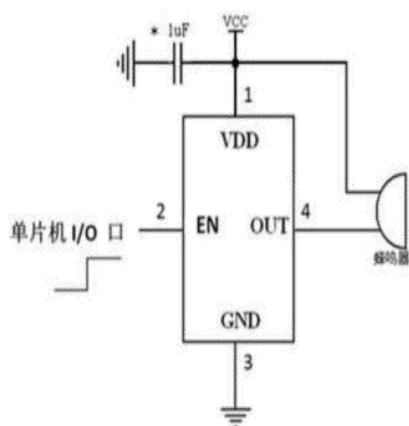

注：*建议在芯片电源输入端增加1uF电源滤波电容。

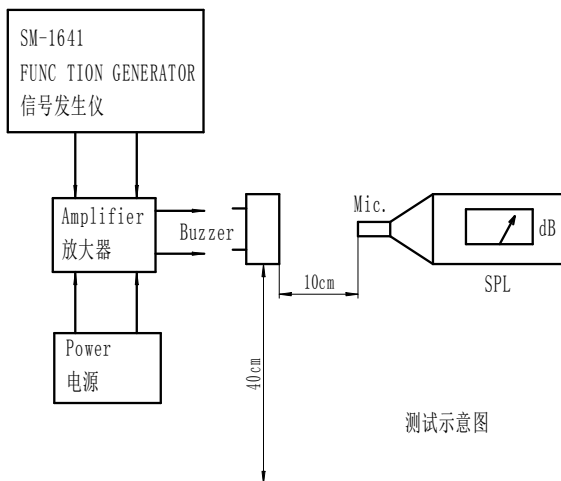

测试示意图

3.可靠性测试/Reliability Test

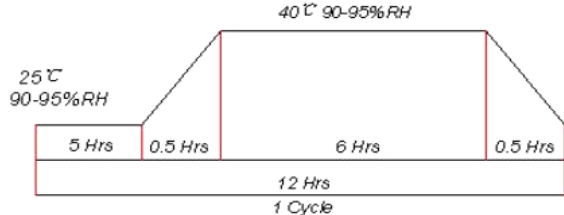
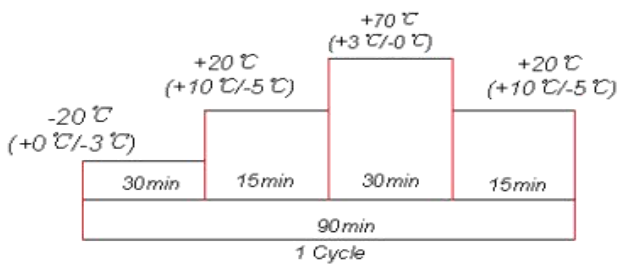
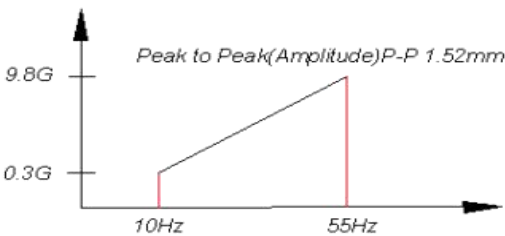
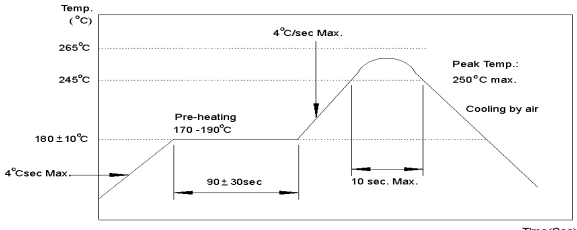
	项目 ITEM	测试方法 TEST
1	高温试验 High Temperature Test	在+80℃±2℃储存温度下存放 96 小时，恢复 2 小时后测试 After being placed in a chamber with +80±2℃ for 96 hours and then being placed in normal condition for 2 hours
2	低温试验 Low Temperature Test	在-20℃±2℃储存温度下存放 96 小时，恢复 2 小时后测试 After being placed in a chamber with -20±2℃ for 96 hours and then being placed in normal condition for 2 hours
3	恒定湿热试验 Humidity Test	
4	温度变化试验 Temperature Cycle Test	
5	振动试验 Vibration Test	
6	跌落试验 Drop Test	70cm 高自由掉落到 40mm 的木板上，每个方向三次 Drop on a hard wood board of 40mm thick, any directions, three times, at the height of 70cm
7	插针的抗拉强度试验 Terminal Strength Pulling Test	插针承受 1.0kg 拉力，负荷时间 5s The force 5 seconds of 1.0kg is applied to each terminal.
8	可焊性试验 Solder ability Test	焊锡温度 255±5℃，浸润时间为 3±0.5s，试验后目测产品情况 Lead terminals are immersed in rosin for 5 seconds and then immersed in solder bath of 255±5℃ for 3±0.5 seconds.
9	回流焊测试 Soldering Test	

--	--	--	--

4.尺寸图 Dimension

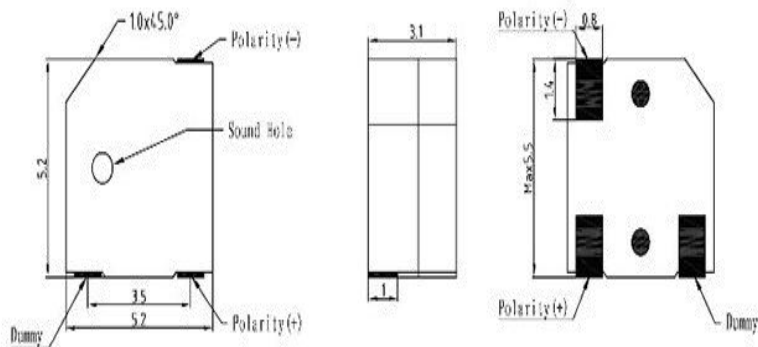

MLT-5030

*Unit: mm; Tolerance: $\pm 0.3\text{mm}$ Except Specified

*Housing Material: Black LCP

5.1 Soldering pattern

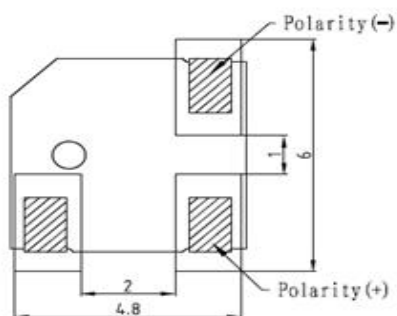

5.2 频率响应/Frequency Response

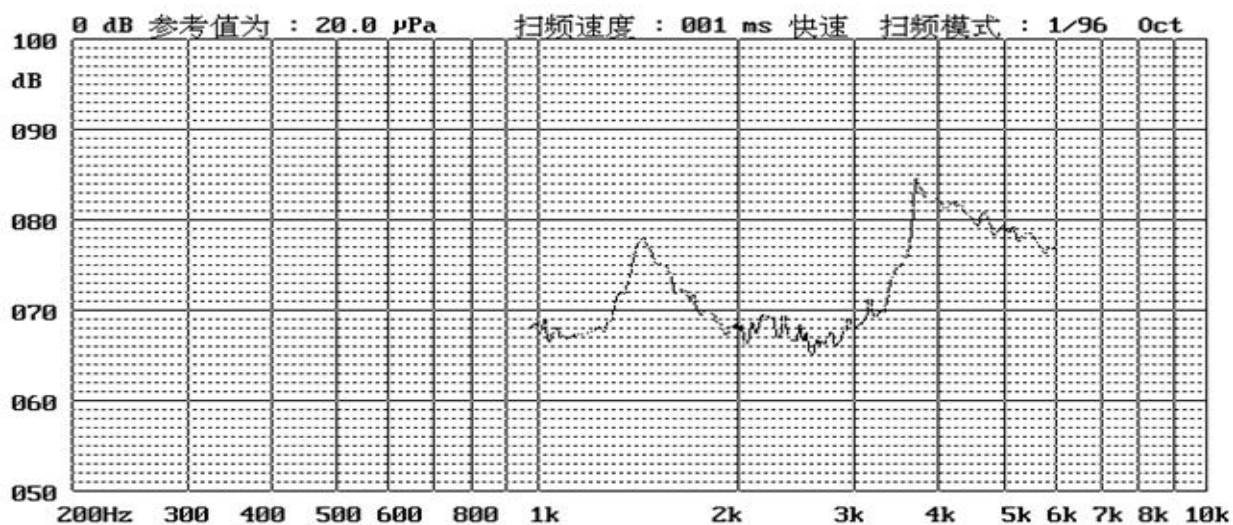

3.0Vo-p 50% duty Square wave, 10cm

6.包装方式/Packing

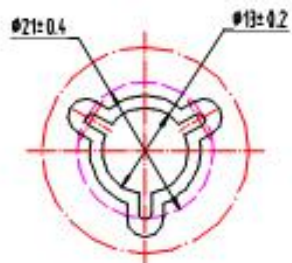
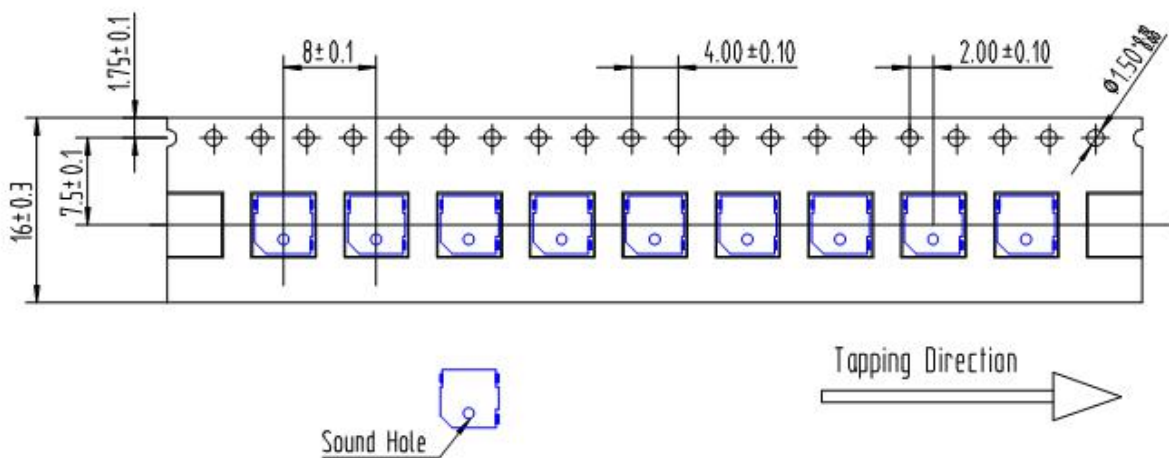

DETAIL: A
SCALE: 8:1

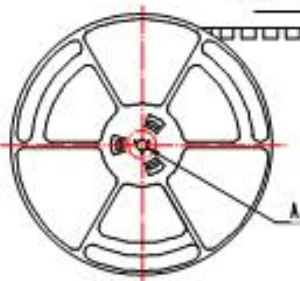

Tapping Direction

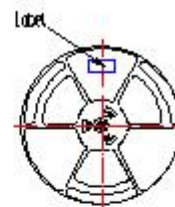
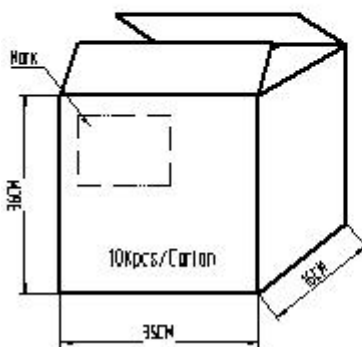

Inside box



1 Reel/Inside box
13*34*35 CM