

样品承认书

Specification For Approval

| | |
|---------------------------|-------------------|
| 客户名称 Customer Name | |
| 品名 Variety | 有源电磁式蜂鸣器 |
| 型号 Part No | SUN-12095-5VPA7.6 |
| 客户型号 The customer Part No | |
| 样品日期 Model Date | |

客户承认签署

| | | |
|----------------------|---------------------|----------------------|
| 签定结果: | | |
| 核准/ <i>Approved:</i> | 审核/ <i>Checked:</i> | 经办/ <i>Designed:</i> |
| | | |

海旭确认签署

| | | |
|----------------------|---------------------|----------------------|
| 核准/ <i>Approved:</i> | 审核/ <i>Checked:</i> | 经办/ <i>Designed:</i> |
| 丁爱勇 | 黄锡梅 | 梁嘉敏 |

承认后请签回一份! *Thank you very much!*

公司地址: 广东省中山市东风镇东风大道南 238 号电星工业园 B 座 4 楼
Email: ZShaixu@163.com Web: <http://www.haixucn.com/>

型号 part No: SUN-12095-5VPA7.6

性能参数 Electrical Characteristics

| | | |
|----|--|---|
| 1 | 额定电压 Rated Voltage (VDC) | 5 |
| 2 | 工作电压 Operating Voltage (VDC) | 4~7 |
| 3 | *在 10cm 处测试声压值 Sound Output at 10cm (dB) | ≥85 |
| 4 | *消耗电流 Current Consumption (mA) | ≤50 |
| 5 | 共振频率 Resonant Frequency (Hz) | 2700±300 |
| 6 | 工作温度 Operating Temperature (°C) | -20~+70 |
| 7 | 储存温度 Storage Temperature (°C) | -30~+80 |
| 8 | 单品重量 Weight (g) | 1.6 |
| 9 | 外壳材料 Housing Material | 黑色 Black PPO |
| 10 | 环保要求 Environmental Protection Regulation | RoHS |
| 11 | 焊接方式 Welding method | 手工焊接 Artificial welding / 波峰焊接 wave soldering |

外形图 DIMENSIONS (UNIT: mm) 未标注公差按±0.5mm 计算 Tolerance: ±0.5mm Except Specified

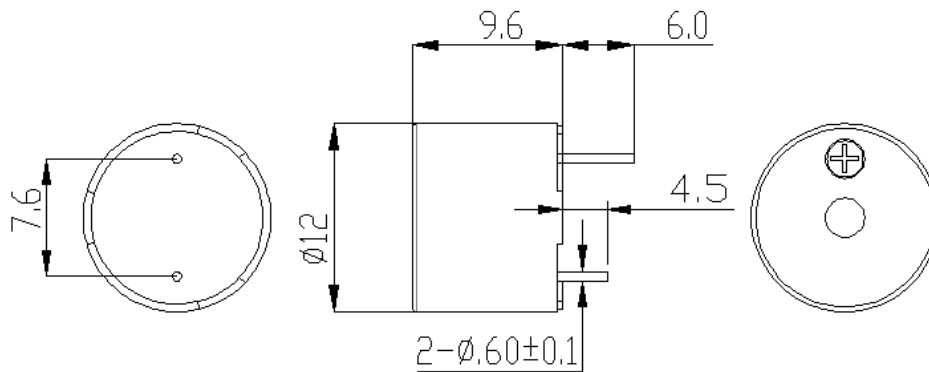

备注：顶部贴防尘贴纸

|  昆山海旭科技电子有限公司 Kunshan Haixu Electronic Technology Co. Ltd | | |
|--|--|--|
| 型号 part No: SUN-12095-5VPA7.6 | | |
| 可靠性测试 RELIABLY TEST | | |
| 项目 ITEM | 测试条件 TESTING CONDITION | 试验后要求 VARIANCE AFTER TEST |
| 高温试验 High Temperature Test | 放置 85±2℃ 96 小时，再室温放置 2 小时。 After being placed in a chamber with 85±2℃ for 96 hours and then being placed in natural condition for 2 hours. | 声压变化±10dB。 Allowable variation of SPL after test: ±10dB. |
| 低温试验 Low Temperature Test | 放置-30±2℃ 96 小时，再室温放置 2 小时。 After being Placed in a chamber with -30±2℃ for 96 hours and then being placed in natural condition for 2 hours. | 声压变化±10dB。 Allowable variation of SPL after test: ±10dB. |
| 恒湿试验 Humidity Test | 存放在温度: 60±5℃湿度: 90%--95%的环境里 96 小时，然后放置到室温下放置 2 小时后测试。 Stored in the temperature humidity: 60±5℃ 90%--95% environment for 96 hours, and then placed into storage at room temperature for 2 hours after the test. | 声压变化±10dB。 Allowable variation of SPL after test: ±10dB. |
| Temperature Cycle Test 温度循环试验 | 放置-30±2℃ 30 分钟、25℃±10℃放置 15 分钟，15 分钟后再将产品放入 +85±2℃30 分钟、常温 25℃±10℃放置 15 分钟，20 个循环后放置常温下 2 小时。 After being placed in a chamber with -30±2℃ for 30 minutes, products shall be placed at room temperature(25℃±10℃).After 15 minutes at this temperature, products shall be placed in a chamber at +85±2℃.After 30 minutes at this temperature, products shall be return to room temperature (25℃±10℃) for 15 minutes. After 20 above cycles, products shall be measured after being placed in natural condition for 2 hours. | 声压变化±10dB。 Allowable variation of SPL after test: ±10dB. |
| Drop Test 跌落试验 | 正面和侧面从 100mm 高度只有跌落在 4cm 厚度的木板上 3 次。 The front and side from a height of 100mm only drop in the 4cm thickness of theboard 3 times each. | 声压变化±10dB。 Allowable variation of SPL after test: ±10dB. |
| Vibration Test 振动试验 | After being applied vibration of amplitude of 1.5mm with 10 to 55 Hz band of vibration frequency to each of 3 perpendicular directions for 2 hours. 频率 10~55Hz, 振幅 1.5mm, 3 个方向, 振动 2 小时。 | 声压变化±10dB。 Allowable variation of SPL after test: ±10dB. |
| Solderability Test 可焊性试验 | Lead terminals are immersed in rosin for 5 seconds and then immersed in solder bath of 265±5℃ for 3±0.5 seconds (Except the edge of terminals). 端子在松香中浸入 5 秒并在 265±5℃锡中浸 3±0.5 秒 | 95% min. lead terminals shall be wet with solder 有 95%吃锡效果。 |

型号 part No: SUN-12095-5VPA7.6

可靠性测试 RELIABLY TEST

| 项目 ITEM | 测试条件 TESTING CONDITION | 试验后要求 VARIANCE AFTER TEST |
|--|---|---|
| Continuous electricity test 连续通电试验 | Temperature: room temperature 25 °C Voltage: rated voltage 5 V Frequency: the rated frequency for 2.7 KHZ Time: 500 hours 温度: 室温 25°C 电压: 额定电压 5V, 频率: 频率 2.7KHz 时间: 500 小时 | 声压变化±10dB。 Allowable variation of SPL after test: ±10dB. |
| Terminal Strength Pulling Test 端子强度试验 | The force of 9.8N(1.0kg) is applied to each terminal in axial direction for 10 seconds. 在每个端子上施加 9.8N (1.0kg) 的轴向力 10 秒。 | No visible damage and cutting off. 端子没有明显的损坏和切断 |

Typical Frequency Response Curve (音频曲线图)

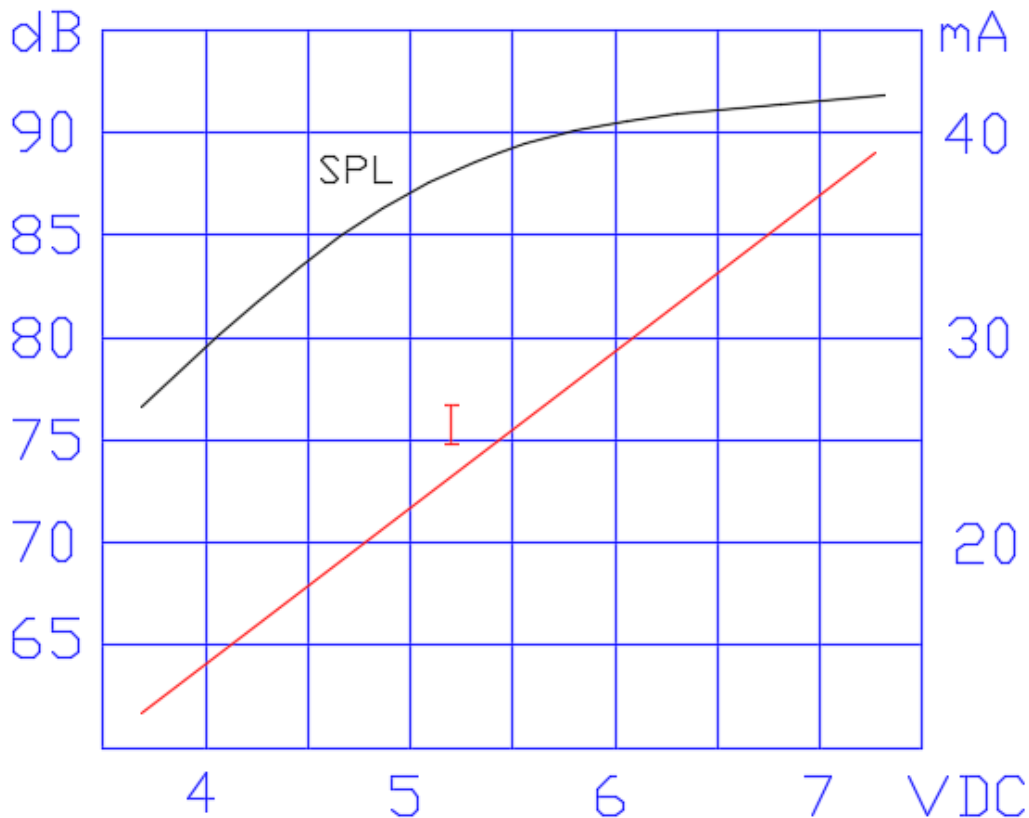

型号 part No: SUN-12095-5VPA7.6

TESTING METHOD (测试方法)

Standard Measurement conditions

Temperature: $25 \pm 2^\circ\text{C}$ Humidity: 45-65%

Acoustic Characteristics:

The oscillation frequency, current consumption and sound pressure are measured by the measuring instruments shown below

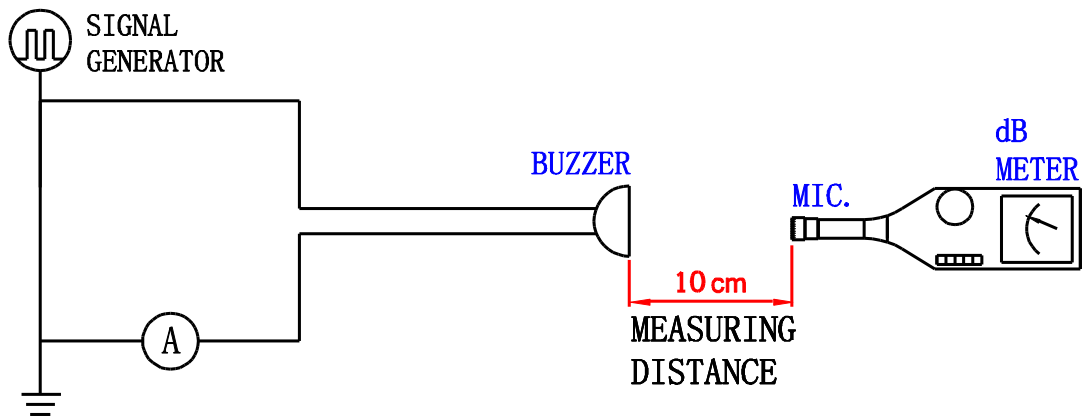

In the measuring test, buzzer is placed as follows:

