



FM1694C (文件编号: S&CIC2086)

Single Pole Double Throw Switch

PRODUCT DESCRIPTION

The FM1694C is very low loss SPDT specifically designed for high performance antenna tuning applications. All RF path performance is enhanced with ultra-low on state resistance and off state capacitance. FM1694C allows the creation of advanced tuning topologies to maximize TRP & TIS performance in space constrained applications.

- Off Ports, 'open Type'
- Two pin GPIO control Interface for standard SP4T operation
- Very Small 1.1mm x 1.5mm, Laminate Package
- Very low profile, 0.44mm
- 2.5V to 4.8V Supply Range (VBATT Connect)

FEATURES

- Ultra-Low On-resistance, 1.0Ω

APPLICATIONS

- Antenna Tuning
- Band Switching
- Impedance Tuning

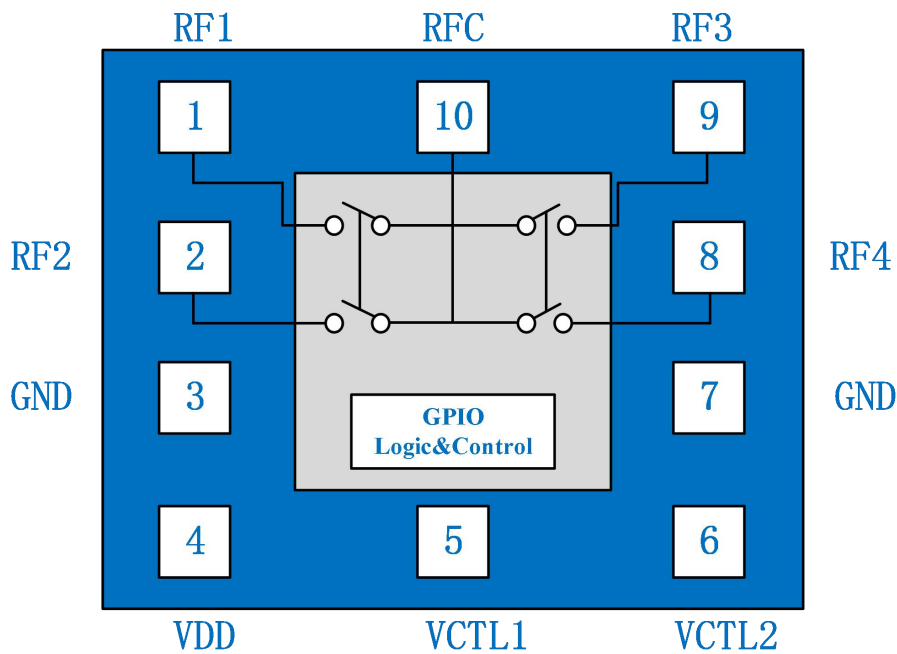

Figure 1. FM1694C Block Diagram

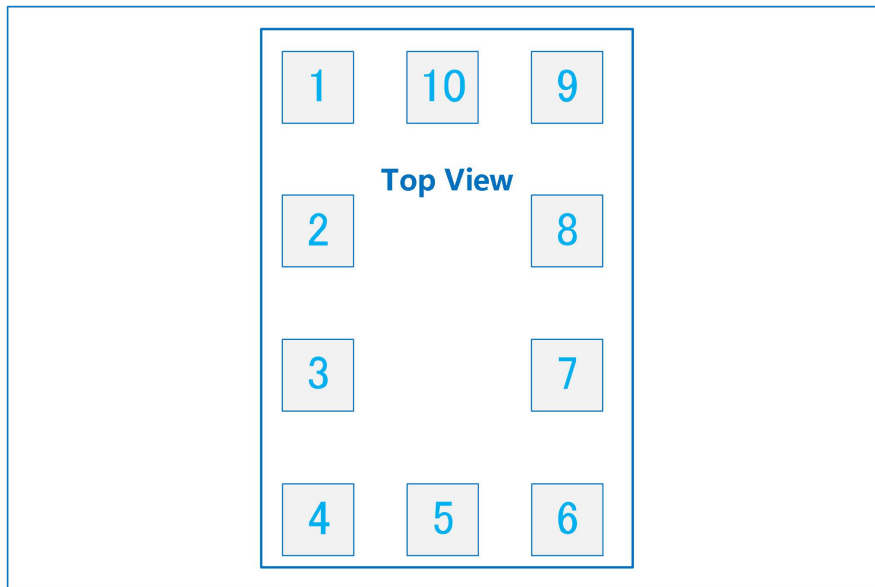

Figure 2. FM1694C Pinout - 10-Pin QFN (Top View)

Table 1.FM1694C Signal Descriptions

Pin#	Name	Details
1	RF1	RF port 1.
2	RF2	RF port 2.
3	GND	Ground
4	VDD	Voltages Supply
5	CTL1	Control Voltage 1.
6	CTL2	Control Voltage 2.
7	GND	Ground
8	RF4	RF port 4
9	RF3	RF port 3.
10	RFC	RF Common port.

Table 2. FM1694C Absolute Maximum Ratings

Parameter	Rating	Unit
Supply Voltage, V_{DD}	+6.0	V
Control Voltage, V_{CTL}	+3.3	V
Max voltage between any combination of RF ports or ground VRF, $V_{DD} = 2.85V_{DC}$, $V_{CTL1/2} = 0/1.8V_{DC}$, Temp = 25°C	36	VP
Operating Case Temperature	-30 to +90	°C
Storage Temperature	-55 to +150	°C
ESD ALL Pins, HBIM, JESD22-A114	2.0	kV



FM1694C (文件编号: S&CIC2086)

Single Pole Double Throw Switch

CAUTION: ESD sensitive device

FM Green: RoHS status based on EU Directive 2011/65/EU (at time of this document revision), halogen free per IEC 61249-2-21, <1000ppm each of antimony trioxide in polymeric materials and red phosphorus as a flame retardant, and <2% antimony in solder.

Exceeding any one or a combination of the Absolute Maximum Rating conditions may cause permanent damage to the device. Extended application of Absolute Maximum Rating conditions to the device reliability. Specified typical performance or functional operation of the device under Absolute Maximum Rating conditions is not implied.

Table 3. FM1694C General Electrical Specifications

(Active Mode $V_{DD} = 2.89V$, $CTL=0/1.8V$, $T_{emp} = +25^{\circ}C$, Characteristic Impedance $[Z_0] = 50 \Omega$)

Parameter	Specification			Unit	Conditions
	Min	Typ	Max		
Operating Frequency	700		2700	MHz	
Supply Voltage V_{DD}	2.5	2.85	4.8	V	
Supply Current I_{DD}		50		μA	
Control Voltage High V_{CLT1} , V_{CLT2}	1.4	1.8	2.7	V	
Control Voltage Low V_{CLT1} , V_{CLT2}	0		0.45	V	
Control Current I_{CTL}		0.1		μA	$V_{CTL} = 1.8V$

Table 4. FM1694C Control Logic

Logic State	Mode	CLT1	CLT2	State Description	RF Applied
1	Low Power	V_{LOW}	V_{LOW}	Low Power Mode	No
2	Active	V_{LOW}	V_{HIGH_CTL}	RFC to RF2 ON	Yes
3	Active	V_{HIGH_CTL}	V_{LOW}	RFC to RF1 ON	Yes
4	Active	V_{HIGH_CTL}	V_{HIGH_CTL}	All Off Mode	Yes

Table 5. FM1694C Electrical Specification

(Active Mode $V_{DD} = 2.85V$, $CTL=0/1.8V$, $T_{emp} = +25^{\circ}C$, Characteristic Impedance $[Z_0] = 50 \Omega$)

Parameter	Specification			Unit	Conditions
	Min	Typ	Max		
Insertion Loss (RFC to RF1 & RF2) LS2 & LS3		0.28	0.40	dB	700 – 915 MHz
		0.40	0.70	dB	915 – 1910 MHz
		0.60	0.95	dB	1910 – 2700 MHz
Isolation (RFC to RF1 & RF2) LS2 & LS3		23		dB	700 – 915 MHz
		20		dB	915 – 1910 MHz
		16		dB	1910 – 2700 MHz
Isolation (RFC to RF1 & RF2)		17		dB	700 – 915 MHz
		13		dB	915 – 1910 MHz



FM1694C (文件编号: S&CIC2086)

Single Pole Double Throw Switch

LS4, All Off Mode		11		dB	1910 – 2700 MHz
Return Loss		20		dB	915 MHz
		15		dB	1910 MHz

Table 6. FM1694C Electrical Specification

(Active Mode $V_{DD} = 2.85V$, $CTL=0/1.8V$, $T_{emp} = +25\text{ }^{\circ}C$, Characteristic Impedance $[Z_0] = 50\ \Omega$)

Parameter	Specification			Unit	Conditions
	Min	Typ	Max		
RON (RFC to RF1/RF2)		1		Ω	100 MHz
Start Up Time		9		μS	10% VDD ramp up to 90% of final RF amplitude
On switching speed		5		μS	90% of final RF amplitude
OFF Switching Speed		5		μS	90% of final RF amplitude
Second Harmonics		-80		dBm	700MHz, Pin = 23 dBm
Third Harmonics		-82		dBm	
Second Harmonics		-55		dBm	915MHz, Pin = 35 dBm
Third Harmonics		-60		dBm	
Second Harmonics		-50		dBm	1910MHz, Pin = 33 dBm
Third Harmonics		-60		dBm	
Second Harmonics		-60		dBm	2570MHz, Pin = 23 dBm
Third Harmonics		-70		dBm	



FM1694C (文件编号: S&CIC2086)

Single Pole Double Throw Switch

Handling Information

FM1694C application schematic is shown in Figure.3. Component value is shown in Table 9.(Note1)

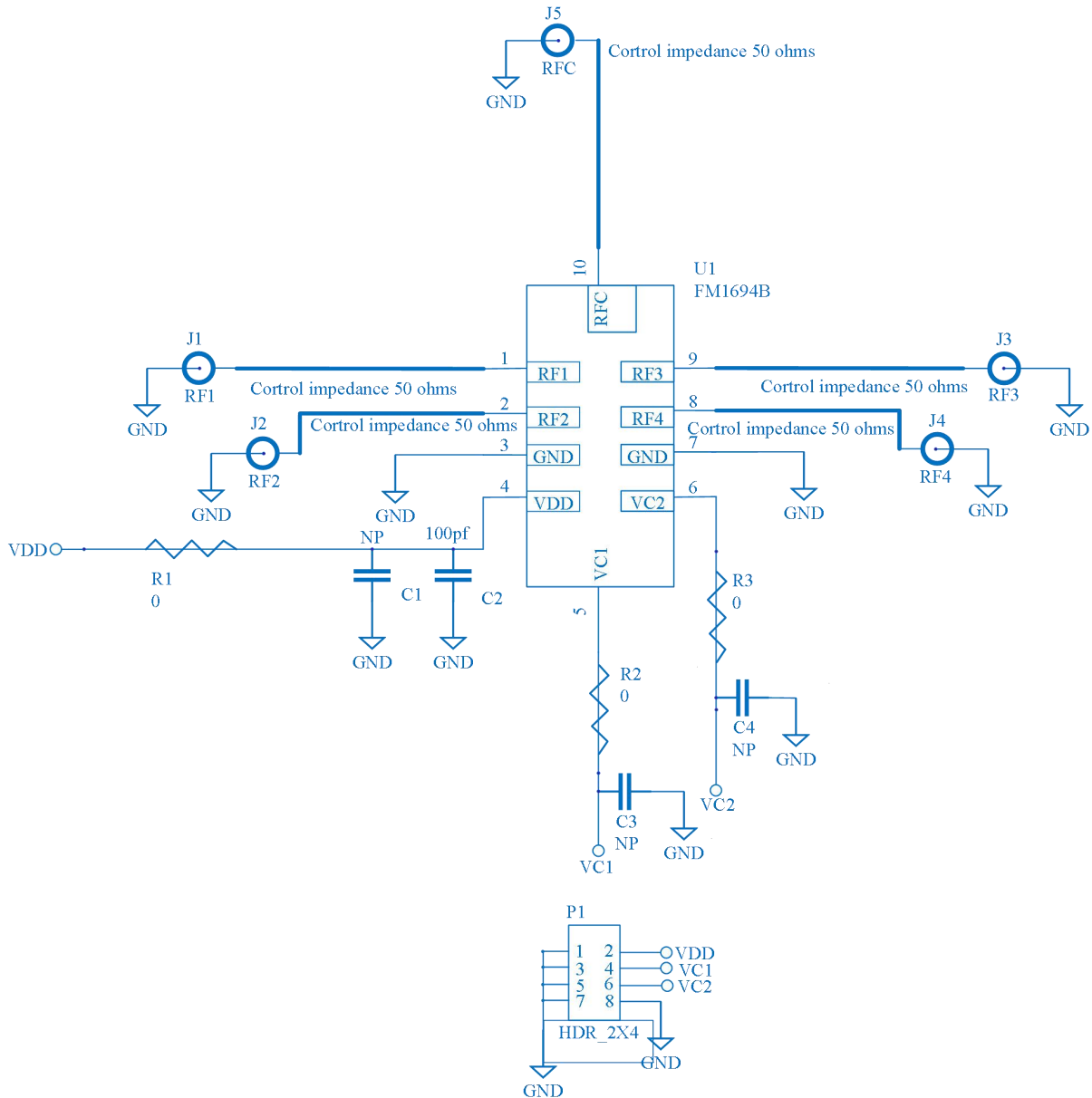

Figure 3. FM1694C Application Schematic



Package Dimensions

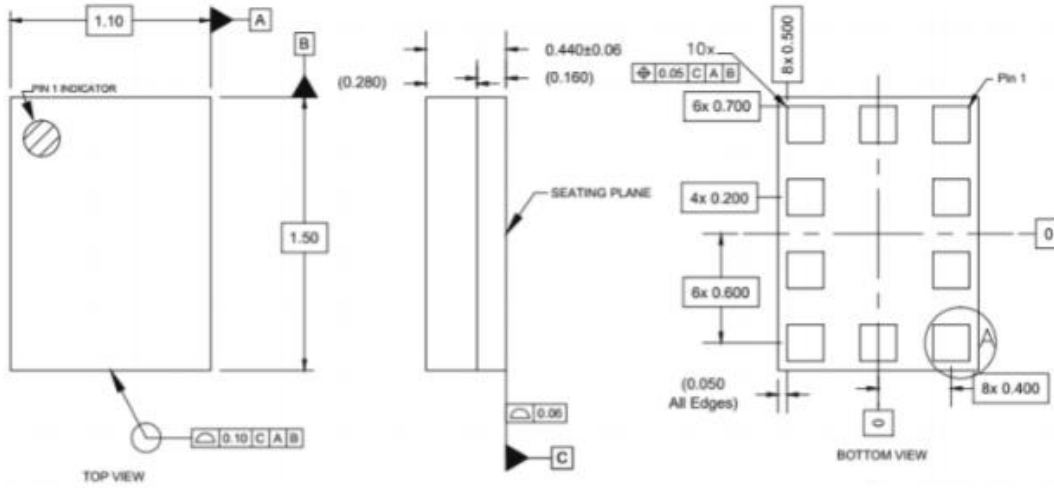

Figure 4. FM1694C 10-Pin QFN Package Dimensions