

## GL Silicon N-Channel Power MOSFET

### General Description :

The GL80N06A4 uses advanced trench technology and design to provide excellent  $R_{DS(ON)}$  with low gate charge. It can be used in a wide variety of applications. The package form is TO-252, which accords with the RoHS standard.

$V_{DSS}$	60	V
$I_D$	80	A
$P_D$	110	W
$R_{DS(ON)type}$	6.0	m $\Omega$

### Features :

- $R_{DS(ON)} < 8.5m\Omega @ V_{GS}=10V$  (Typ6m $\Omega$ )
- High density cell design for ultra low  $R_{dson}$
- Fully characterized avalanche voltage and current
- Excellent package for good heat dissipation

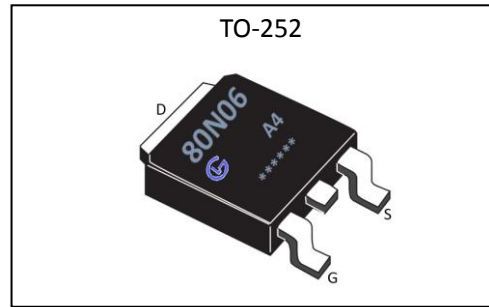

### Applications :

- Power switching application
- Hard switched and high frequency circuits
- Uninterruptible power supply

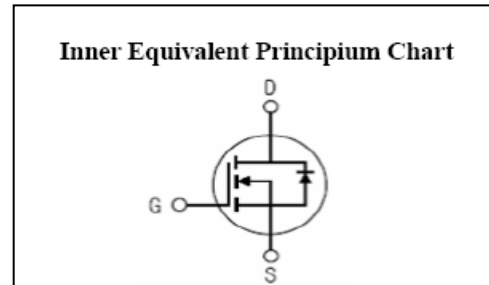

### Absolute ( $T_c = 25^\circ C$ unless otherwise specified ) :

Symbol	Parameter	Rating	Units
$V_{DSS}$	Drain-to-Source Voltage	60	V
$I_D$	Continuous Drain Current	80	A
$I_{DM}$	Pulsed Drain Current	180	A
$V_{GS}$	Gate-to-Source Voltage	$\pm 20$	V
$P_D$	Power Dissipation	110	W
$E_{AS}$	Single pulse avalanche energy <sup>a5</sup>	390	mJ
$T_J, T_{stg}$	Operating Junction and Storage Temperature Range	175 , -55 to 175	$^\circ C$



# GL80N06A4

无锡光磊电子科技有限公司

## GL Silicon N-Channel Power MOSFET

Electrical Characteristics (  $T_c = 25^\circ\text{C}$  unless otherwise specified ) :

OFF Characteristics						
Symbol	Parameter	Test Conditions	Rating			Units
			Min.	Typ.	Max.	
$V_{DSS}$	Drain to Source Breakdown Voltage	$V_{GS}=0V, I_D=250\mu A$	60	--	--	V
$I_{DSS}$	Drain to Source Leakage Current	$V_{DS}=60V, V_{GS}=0V, T_a=25^\circ\text{C}$	--	--	1.0	$\mu A$
$I_{GSS(F)}$	Gate to Source Forward Leakage	$V_{GS}=+20V$	--	--	0.1	$\mu A$
$I_{GSS(R)}$	Gate to Source Reverse Leakage	$V_{GS}=-20V$	--	--	-0.1	$\mu A$

ON Characteristics <sup>a3</sup>						
Symbol	Parameter	Test Conditions	Rating			Units
			Min.	Typ.	Max.	
$R_{DS(ON)}$	Drain-to-Source On-Resistance	$V_{GS}=10V, I_D=40A$	--	6.0	8.5	$m\Omega$
$V_{GS(TH)}$	Gate Threshold Voltage	$V_{DS}=V_{GS}, I_D=250\mu A$	1.0	--	2.5	V

Pulse width  $t_p \leq 380\mu s, \delta \leq 2\%$

Dynamic Characteristics <sup>a4</sup>						
Symbol	Parameter	Test Conditions	Rating			Units
			Min.	Typ.	Max.	
$g_{fs}$	Forward Transconductance	$V_{DS}=10V, I_D=40A$	20	--	--	S
$C_{iss}$	Input Capacitance	$V_{GS}=0V, V_{DS}=30V$ $f=1.0\text{MHz}$	--	4000	--	pF
$C_{oss}$	Output Capacitance		--	290	--	
$C_{rss}$	Reverse Transfer Capacitance		--	210	--	

Resistive Switching Characteristics <sup>a4</sup>						
Symbol	Parameter	Test Conditions	Rating			Units
			Min.	Typ.	Max.	
$t_{d(ON)}$	Turn-on Delay Time	$V_{DD}=30V, R_L=1\Omega$ $V_{GS}=10V, R_G=3\Omega$	--	8.5	--	ns
$t_r$	Rise Time		--	7	--	
$t_{d(OFF)}$	Turn-Off Delay Time		--	40	--	
$t_f$	Fall Time		--	15	--	
$Q_g$	Total Gate Charge	$V_{DD}=30V, I_D=20A$ $V_{GS}=10V$	--	90	--	nC
$Q_{gs}$	Gate to Source Charge		--	9	--	
$Q_{gd}$	Gate to Drain ( "Miller" ) Charge		--	18	--	

## GL Silicon N-Channel Power MOSFET

Source-Drain Diode Characteristics						
Symbol	Parameter	Test Conditions	Rating			Units
			Min.	Typ.	Max.	
$I_S$	Continuous Source Current <sup>a2</sup> (Body Diode)		--	--	80	A
$V_{SD}$	Diode Forward Voltage <sup>a3</sup>	$I_S=80A, V_{GS}=0V$	--	--	1.2	V

Symbol	Parameter	Typ.	Units
$R_{\theta JC}$	Junction-to-Case <sup>a2</sup>	1.36	°C/W

<sup>a1</sup> : Repetitive Rating: Pulse width limited by maximum junction temperature.

<sup>a2</sup> : Surface Mounted on FR4 Board,  $t \leq 10\text{sec}$ .

<sup>a3</sup> : Pulse Test: Pulse Width  $\leq 300\mu\text{s}$ , Duty Cycle  $\leq 2\%$ .

<sup>a4</sup> : Guaranteed by design, not subject to production

<sup>a5</sup> : EAS condition :  $T_j=25^\circ\text{C}, V_{DD}=20\text{V}, V_G=10\text{V}, L=0.5\text{mH}, R_g=25\Omega$

### Test circuit

#### 1) EAS test Circuit

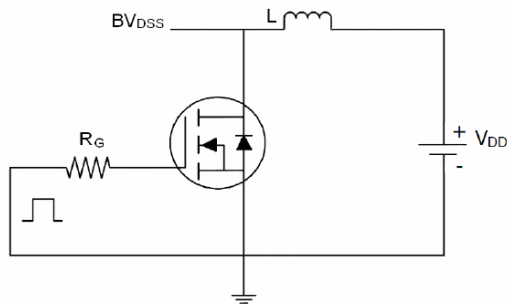

#### 2) Gate charge test Circuit

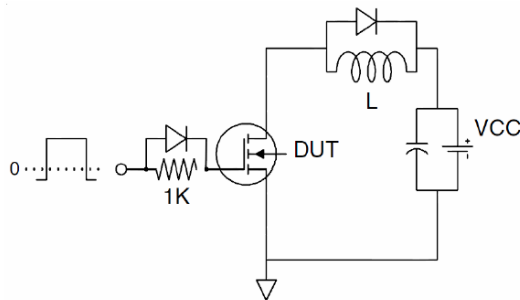

#### 3) Switch Time Test Circuit

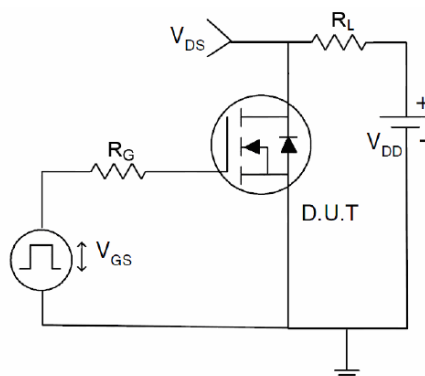



## GL Silicon N-Channel Power MOSFET

### Characteristics Curve :

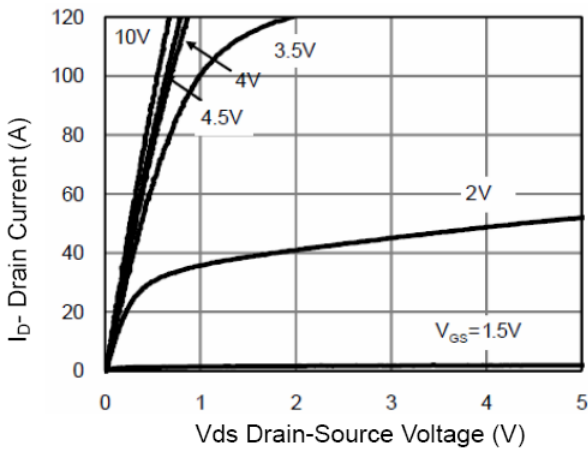

Figure 1 Output Characteristics

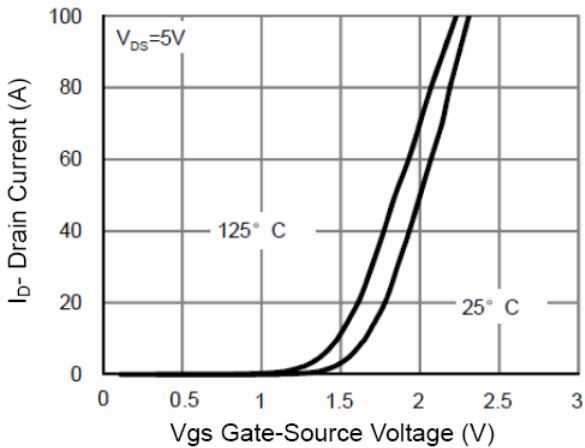

Figure 2 Transfer Characteristics

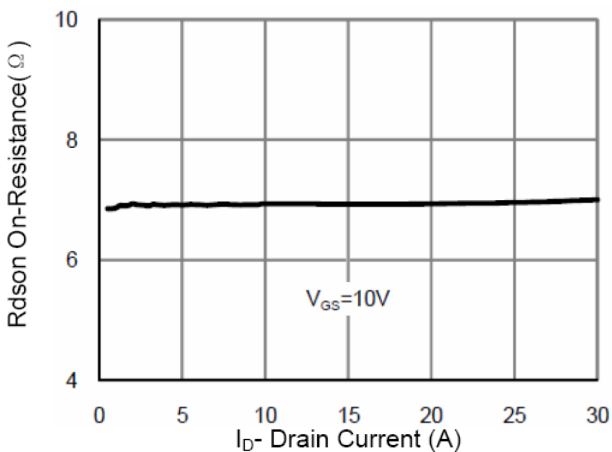

Figure 3 Rds(on)- Drain Current

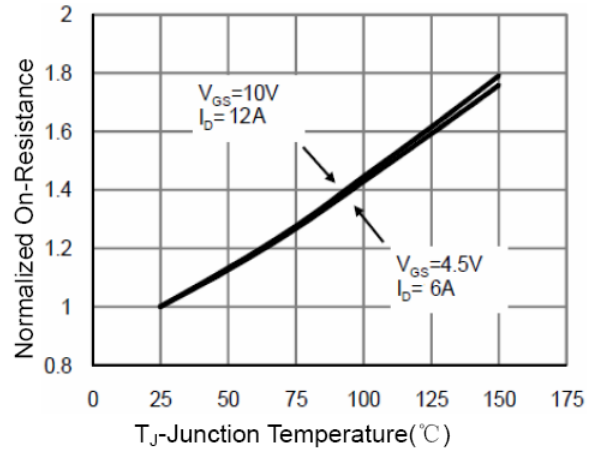

Figure 4 Rds(on)-Junction Temperature

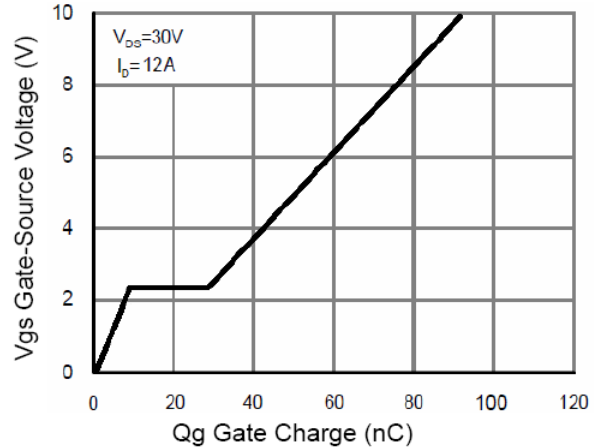

Figure 5 Gate Charge

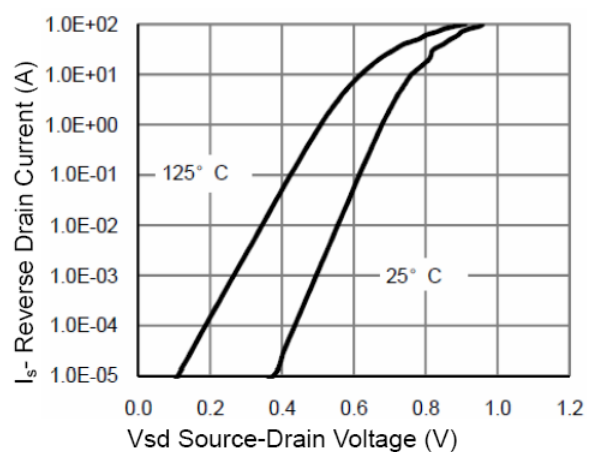

Figure 6 Source- Drain Diode Forward



GL Silicon N-Channel Power MOSFET

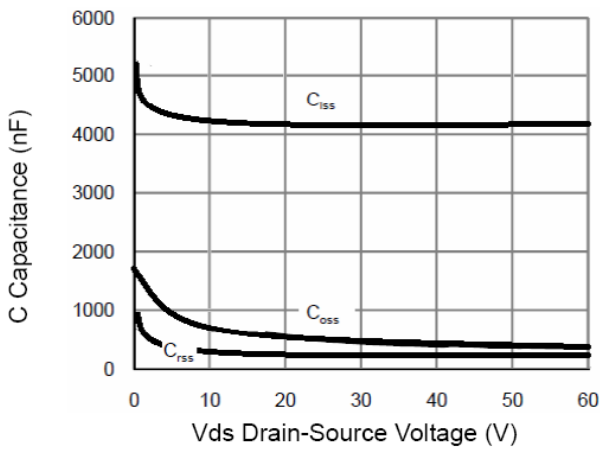

Figure 7 Capacitance vs Vds

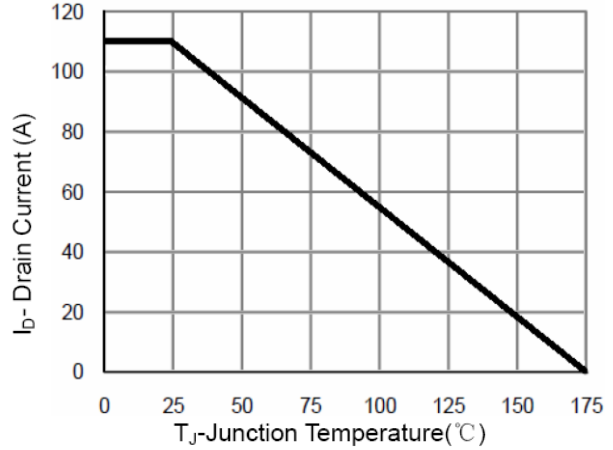

Figure 9 Current De-rating

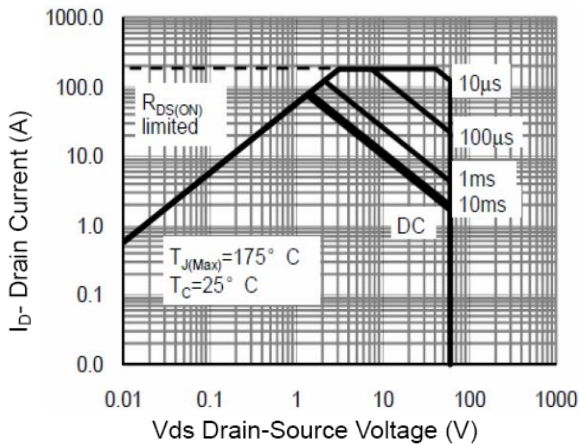

Figure 8 Safe Operation Area

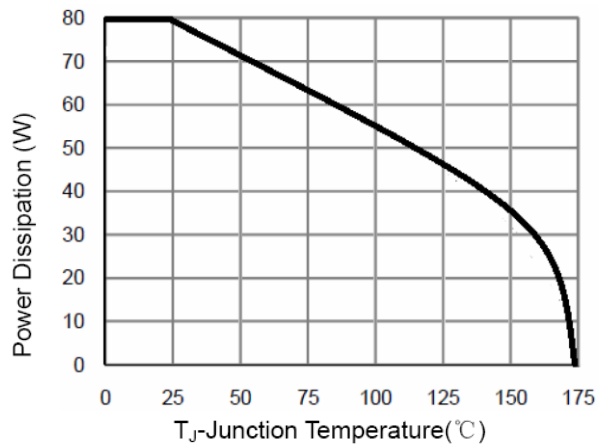

Figure 10 Power De-rating

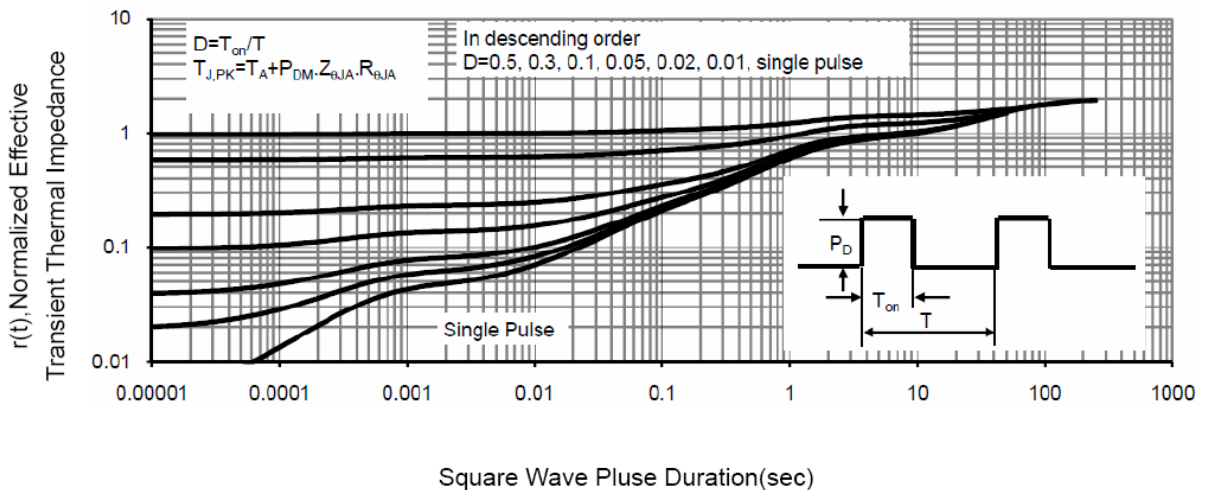

Figure 11 Normalized Maximum Transient Thermal Impedance

TEL:0755-23068119