

Technology Request:
 1.Outlook:No burr, no hurt.
 2.Electronic performance:
 a:Insulation resistance: Above DC500V/100MΩ;
 b:Endure voltage:AC500V at 1 minute;
 c:Contact resistance:Under 30mΩ;
 3.Insertion force & withdrawal force:0.3–3kgf.
 4.Salt spray test:24H.
 5.Meet RoHS.
 6.Remark * is important specification.

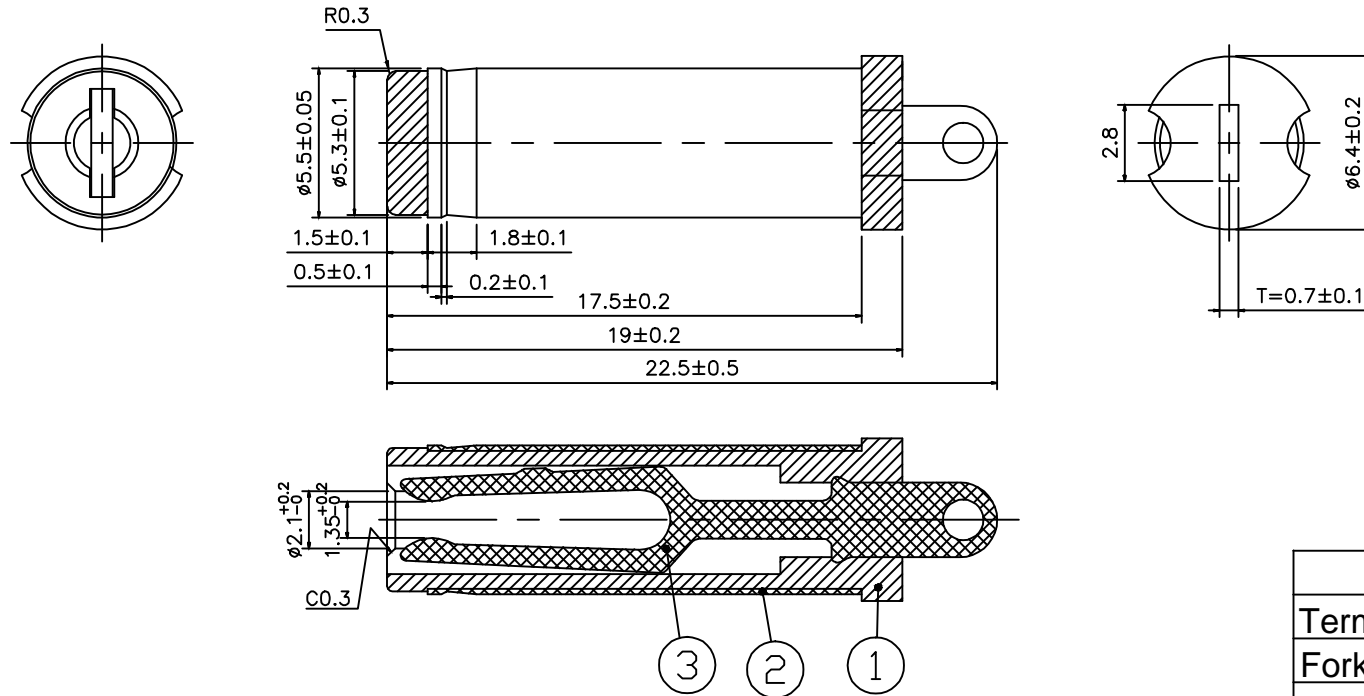

	MATERIAL	PLATING
Terminal	phosphor bronze	NI
Fork hook tube	H65	NI
Plastic	Pbt	Black

					DSND	DATE	SCALE: N/A	MODEL TYPE:		
ΔX					ANGLAR		VIEW:	DC PIUG		
ΔX					±5°		UNIT: mm	PART NO.: DT-2255521		
ΔX					±0.2mm		SIZE: A4	DWG NO.:		
MARK	DESCRIPTION	DATE	REVISED	APPROVED	X.X					
	REVISIONS				X.XX					
					X.XXX					
					UNSPECIFIED TOLERANCES					
XKB INDUSTRIAL PRECISION CO.,LIMITED								WEIGHT	SHEET	REVISION
www.xk-dg.cn www.helloddb.com www.helloddb.cn								1.0g	1/1	A0