

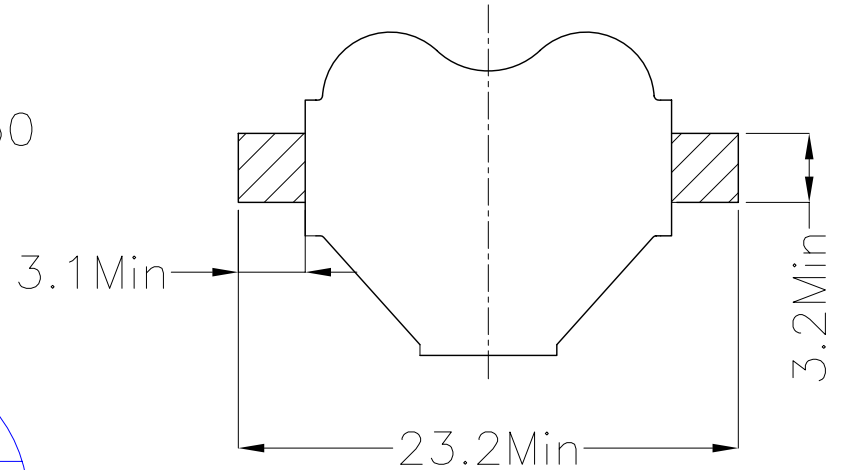

A型

REV.	ECN NO.	REVISED	DATE

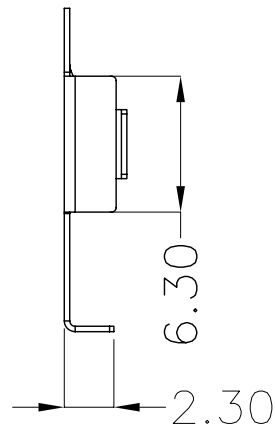
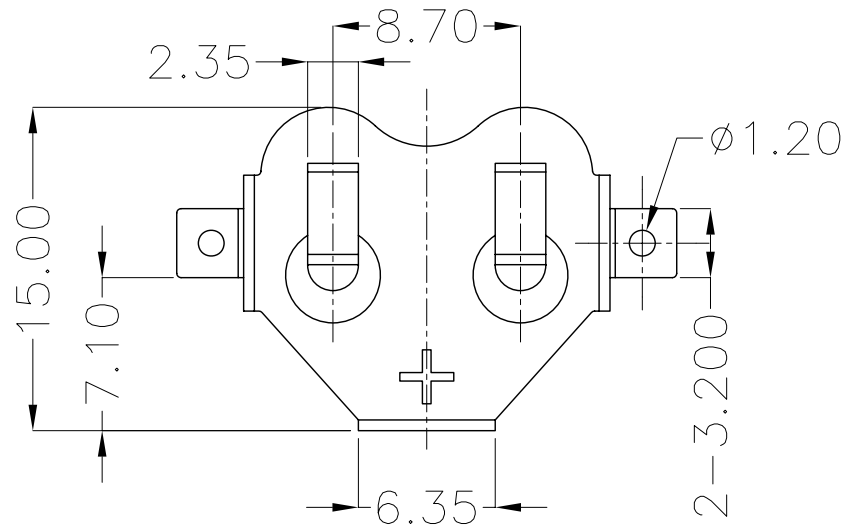

PCB Layout Diagram
Top View

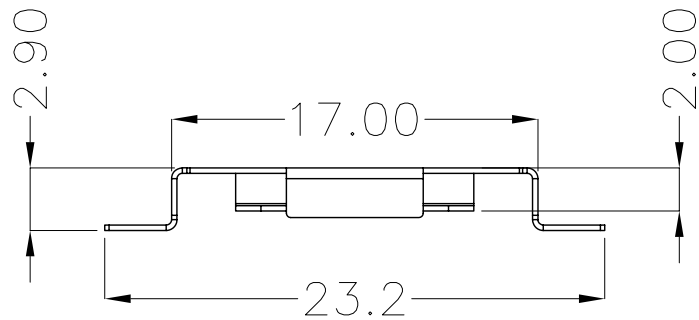

工程部
2017-03-10
ZW DANG

UNLESS OTHERWISE SPECIFIED TOLERANCES		MYOUNG 美阳 www.meiyangdz.com			
DECIMALS: X :±0.30 X.X :±0.25 X.XX :±0.20 X.XXX :±0.10	ANGLES: X :±1° X.X :±0.5°	DSND	YangFeng	DATE	2017-03-10
WEIGHT: 0.53g		CHKD	ZhouRuicai	DATE	2017-03-10
SHEET 1 OF 1		APVD	XueShunyong	DATE	2017-03-10
TITLE:		SCALE:	3:1	SIZE:	A4
PART NO.:		VIEW:	⊙ ↺	UNIT:	mm
DRAW NO.:MY-CP-0043		REV.:	A/0	OBJECT:	MY
MY-1620-01		DATE			

1	TERMINAL(+)	1	PHOSPHOR BRONZE, T=0.25mm	Ni-Plating
NO.	PART NAME	Q'TY	MATERIAL	PLATING & COLOR

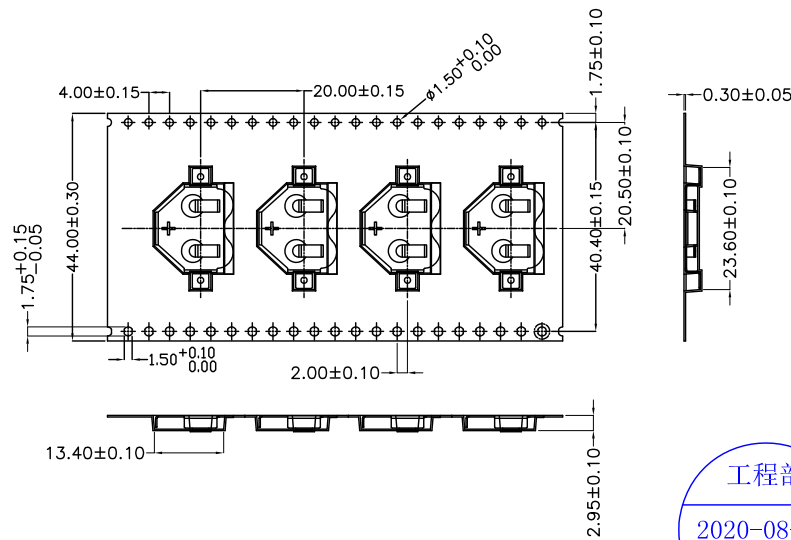
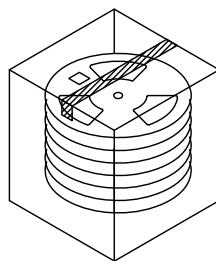
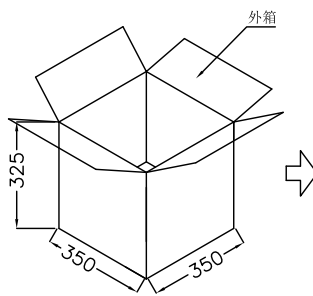
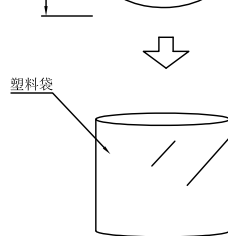
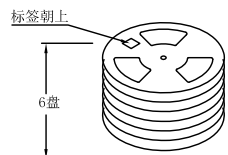
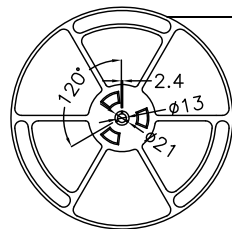
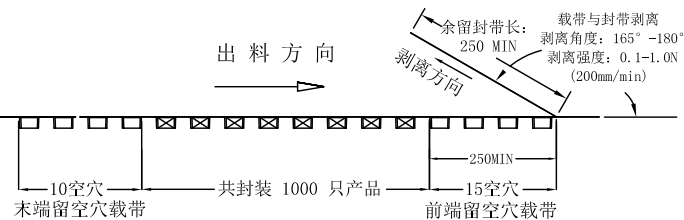
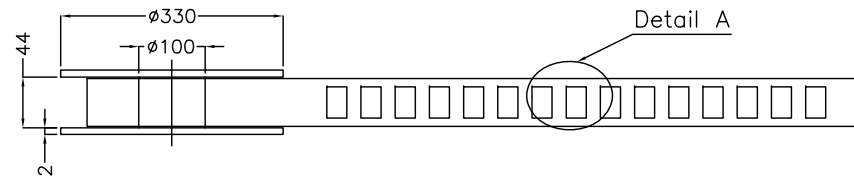
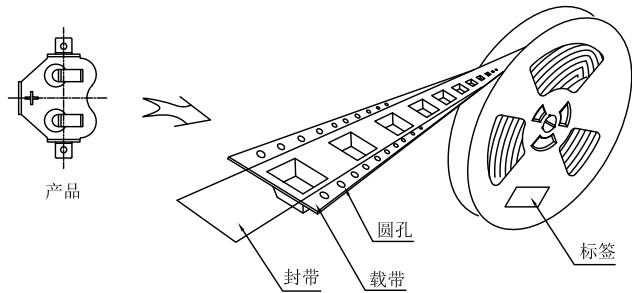

Detail A



技术要求:

1. 圆孔十个孔距离累计允许公差为±0.2mm
2. 带长250mm内容许弯曲度1mm
3. 材料厚度以在载带边缘测量为准
4. 所有尺寸定义依循EIA-481-C系准则定义之
5. 材料: 黑色PS T=0.30mm
6. 所有卷轮为灰蓝挖空旋转塑胶卷轮
7. 整模成型长度:20.5M,
8. 非指明公差范围为: ±0.1mm; 超过250mm不计算累计误差
9. 型腔外形凡未标明处倒角R为0.2-0.3; 拔模斜度未标注的为3° 以下

包装信息:

- 1、每卷盘装产品 1000 只, 卷盘外侧贴相关标签;
- 2、每 6 卷盘放在一个塑料袋中;
- 3、每外箱装6盘, 产品总数: 6000 只;
- 4、外箱上下用胶纸封成“工”字;
- 5、净重: 3.18 KG, 毛重: 6.5KG.

UNLESS OTHERWISE SPECIFIED TOLERANCES		MYOUNG 美阳 www.meiyangdz.com				
DECIMALS: X : ±*** X.X : ±*** X.XX : ±*** X.XXX : ±***	ANGLES: X : ±*** X.X : ±***	DSND	YangFeng	DATE	2020-08-22	TITLE: 电池扣CR1620-W SMT卷装
WEIGHT:		CHKD	ZhouRuicai	DATE	2020-08-22	PART NO.:
SHEET 1 OF 1		APVD	XueShunyong	DATE	2020-08-22	MY-1620-01-R
		SCALE:	SIZE: A4	VIEW:		DRAW NO.:MY-BD-0024
		UNIT: mm	REV.: A/0	OBJECT:	MY	