

Features

- High input voltage: 60V
- Low temperature coefficient
- Integrated Short-Circuit Protection
- High PSRR: 70dB at 1KHz
- Good Transient Response
- Large Output Current: 150mA
- Low Quiescent Current: 2uA
- Output voltage accuracy: tolerance $\pm 2\%$
- Built-in current limiter
- Dropout Voltage: 70mV@10mA/700mV@100mA
- High Input Voltage Rating: Up to 80V
- SOT89-3, SOT23-3 and SOT23-5 packages

Applications

- Battery-powered equipment
- Home Appliance
- Smoke detector and sensor
- Microcontroller Applications

General Description

The SSP7985 series is a group of positive voltage output, three-pin regulators, that provide a high current even when the input/output voltage differential is small. Low power consumption and high accuracy is achieved through CMOS and laser trimming technologies.

The SSP7985 consists of a high-precision voltage reference, an error amplification circuit, and a current limited output driver. Transient response to load variations have improved in comparison to the existing series. SOT89-3, SOT23-3 and SOT23-5 packages are available.

Order Information

SSP7985P①②③④

Designator	Symbol	Description
① ②	Integer	Output Voltage(2.5V~5.0V)
③	P	Package:SOT89-3
	M	Package:SOT23-3
	M5	Package:SOT23-5
④	R	RoHS / Pb Free
	G	Halogen Free

Note: "①②" stands for output voltages. Other voltages can be specially customized.

Selection Table

Part No.	Output Voltage	Package
SSP7985P25XX	2.5V	SOT89-3 SOT23-3 SOT23-5
SSP7985P27XX	2.7V	
SSP7985P30XX	3.0V	
SSP7985P33XX	3.3V	
SSP7985P36XX	3.6V	
SSP7985P40XX	4.0V	
SSP7985P44XX	4.4V	
SSP7985P50XX	5.0V	

Typical Application

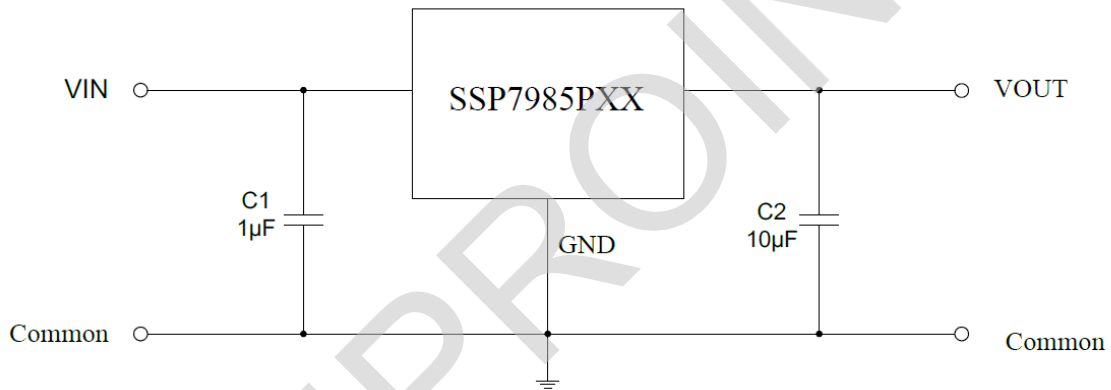

Block Diagram

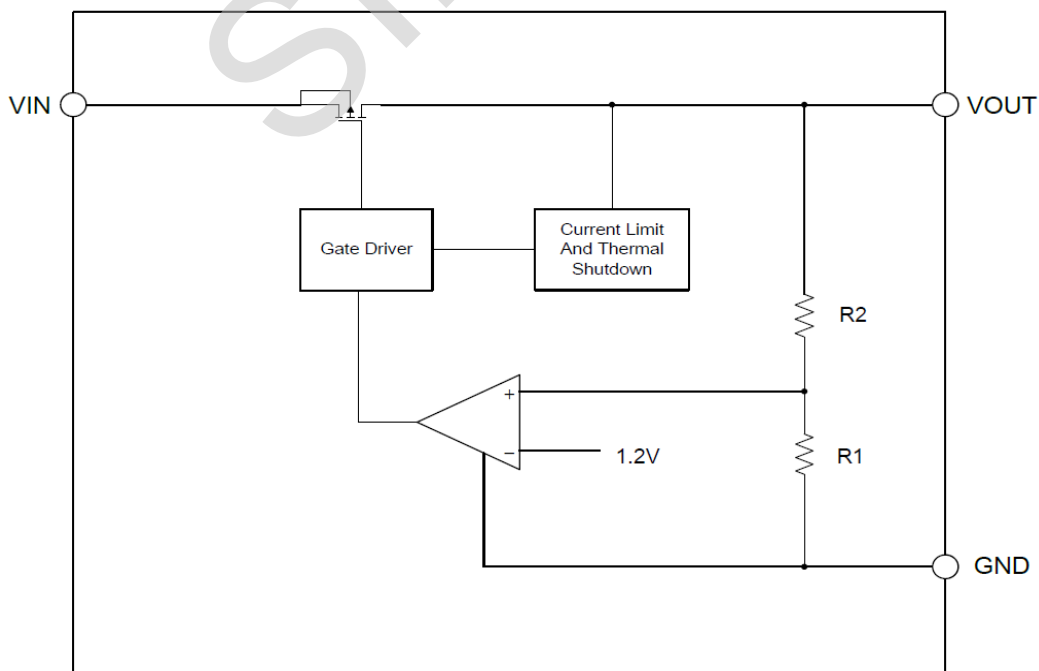

Pin Assignment

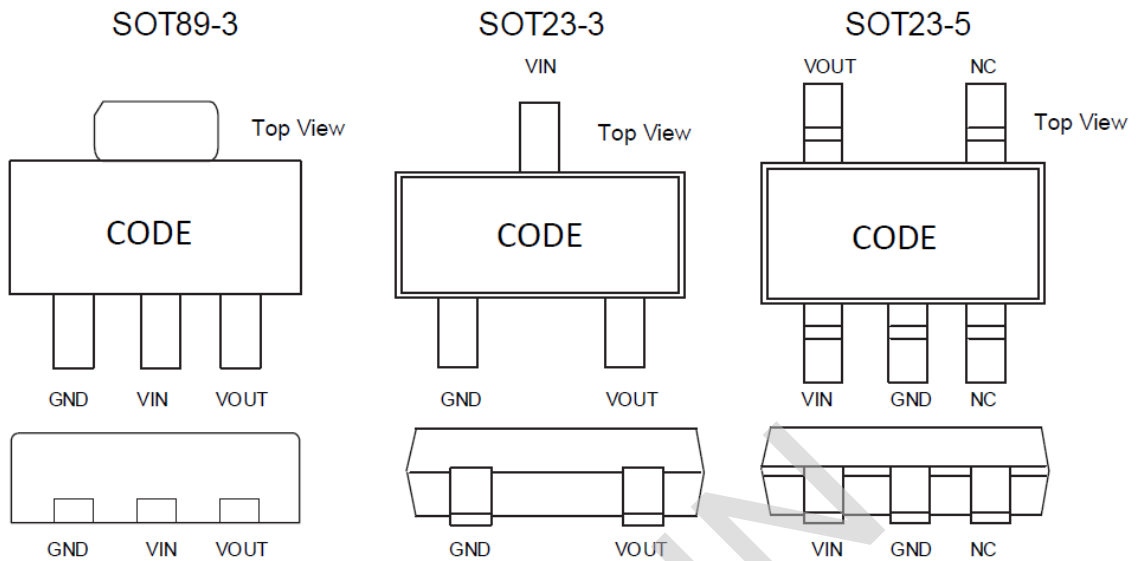

Absolute Maximum Ratings

Item	Description	Min	Max	Unit
Voltage	VIN Pin to GND Pin	-0.3	80	V
	VOUT Pin to GND pin	-0.3	6	V
	VOUT Pin to VIN Pin	-35	0.3	V
Current	Peak output	Internally limited		
Temperature	Operating Ambient Temperature	-40	85	°C
	Storage Temperature	-40	150	°C
	Operating virtual junction Temperature	-	150	°C
Thermal Resistance (Junction to Ambient)	SOT89-3	180		°C/W
	SOT23-3	380		°C/W
	SOT23-5	300		°C/W
Power Dissipation	SOT89-3	600		mW
	SOT23-3	300		mW
	SOT23-5	400		mW
Electrostatic discharge rating	Human Body Model (HBM)	4		kV
	Charged Device Model (MM)	100		V

Note: Stresses exceeding the range specified under “Absolute Maximum Ratings” may cause substantial damage to the device. Functional operation of this device at other conditions beyond those listed in the specification is not implied and prolonged exposure to extreme conditions may affect device reliability.

Electrical Characteristics

(At $T_A=25^\circ\text{C}$, $C_{IN}=1\mu\text{F}$, $V_{IN}=V_{OUTNOM}+1.0\text{V}$, $C_{OUT}=10\mu\text{F}$, unless otherwise noted)

Symbol	Parameter	Test Conditions	MIN	TYP	MAX	UNIT
V_{IN}	Input Voltage		5	—	60	V
I_{GND}	Quiescent Current	$V_{IN}=12\text{V}$, No load	—	2	—	μA
V_{OUT}	Output Voltage	$V_{IN}=12\text{V}$, $I_{OUT}=10\text{mA}$	V_{OUTNOM}^* 0.98	V_{OUTNOM}	V_{OUTNOM}^* 1.02	V
I_{OUT_MAX}	Output Current		—	150	—	mA
V_{DROP}	Dropout Voltage(1)	$I_{OUT}=10\text{mA}$, $V_{IN}=V_{OUTNOM}-0.1\text{V}$	—	70	—	mV
		$I_{OUT}=100\text{mA}$, $V_{IN}=V_{OUTNOM}-0.1\text{V}$	—	700	—	mV
$\Delta V_{OUT}(\Delta I_{OUT})$	Load Regulation	$V_{IN}=12\text{V}$, $1\text{mA}\leq I_{OUT}\leq 100\text{mA}$	—	0.02	—	%/mA
$\Delta V_{OUT}(\Delta V_{IN})$	Line Regulation	$I_{OUT}=1\text{mA}$, $V_{OUTNOM}+0.5\text{V}\leq V_{IN}\leq 60\text{V}$	—	0.01	—	%/V
I_{LIMIT}	Current Limit		—	250	—	mA
T_{SHDN}	Thermal Shutdown Temperature	Shutdown, temperature increasing	—	150	—	$^\circ\text{C}$
		Reset, temperature decreasing	—	140	—	
PSRR		$V_{in}=12\text{V}$, $I_{out}=10\text{mA}$ $F=1\text{KHz}$, $V_{out}=3.3\text{V}$	—	70	—	dB

Note: *1 Dropout Voltage is the voltage difference between the input and the output at which the output voltage drops 2% below its nominal value.

Package Information

3-pin SOT89 Outline Dimensions

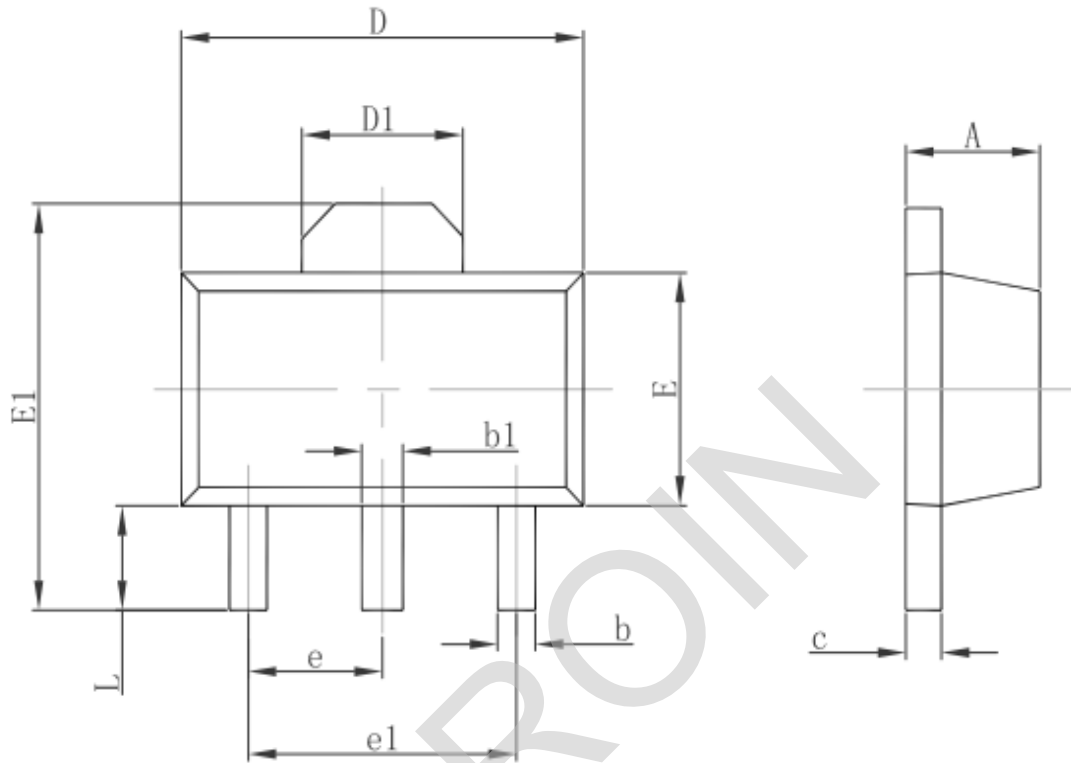

Symbol	Dimensions In Millimeters		Dimensions In Inches	
	Min.	Max.	Min.	Max.
A	1.400	1.600	0.055	0.063
b	0.320	0.520	0.013	0.020
b1	0.400	0.580	0.016	0.023
c	0.350	0.440	0.014	0.017
D	4.400	4.600	0.173	0.181
D1	1.550 REF.		0.061 REF.	
E	2.300	2.600	0.091	0.102
E1	3.940	4.250	0.155	0.167
e	1.500 TYP.		0.060 TYP.	
e1	3.000 TYP.		0.118 TYP.	
L	0.900	1.200	0.035	0.047

3-pin SOT23-3 Outline Dimensions

SOT-23-3L PACKAGE OUTLINE DIMENSIONS

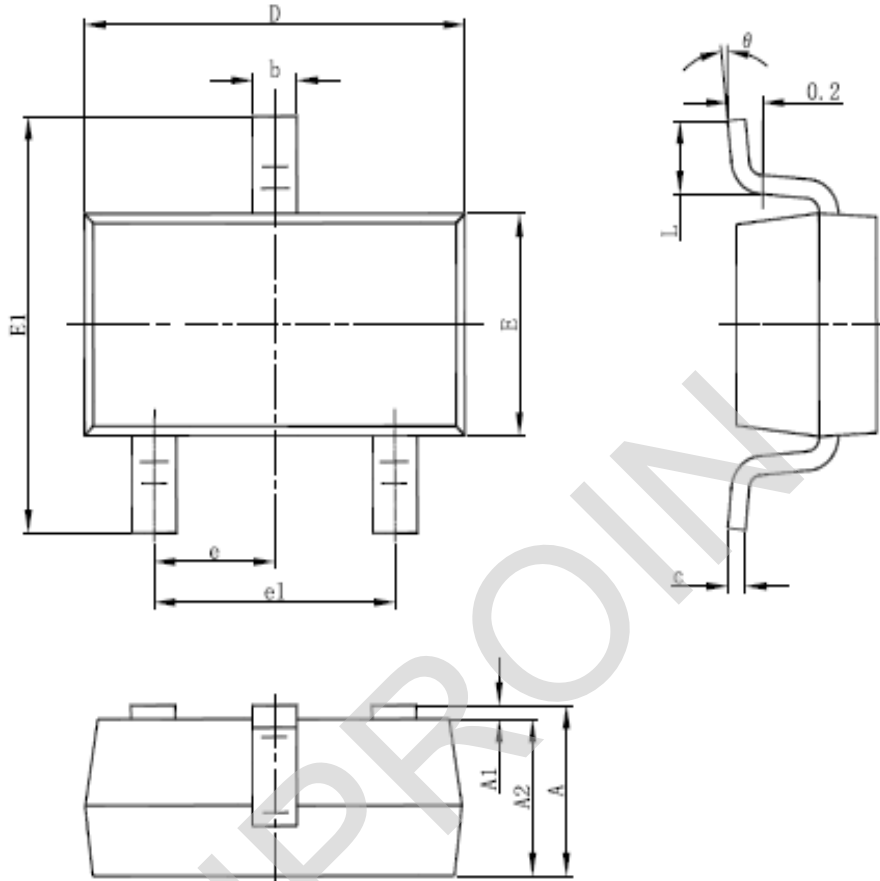

Symbol	Dimensions In Millimeters		Dimensions In Inches	
	Min	Max	Min	Max
A	1.050	1.250	0.041	0.049
A1	0.000	0.100	0.000	0.004
A2	1.050	1.150	0.041	0.045
b	0.300	0.500	0.012	0.020
c	0.100	0.200	0.004	0.008
D	2.820	3.020	0.111	0.119
E	1.500	1.700	0.059	0.067
E1	2.650	2.950	0.104	0.116
e	0.950(BSC)		0.037(BSC)	
e1	1.800	2.000	0.071	0.079
L	0.300	0.600	0.012	0.024
θ	0°	8°	0°	8°

SOT23-5 Outline Dimensions

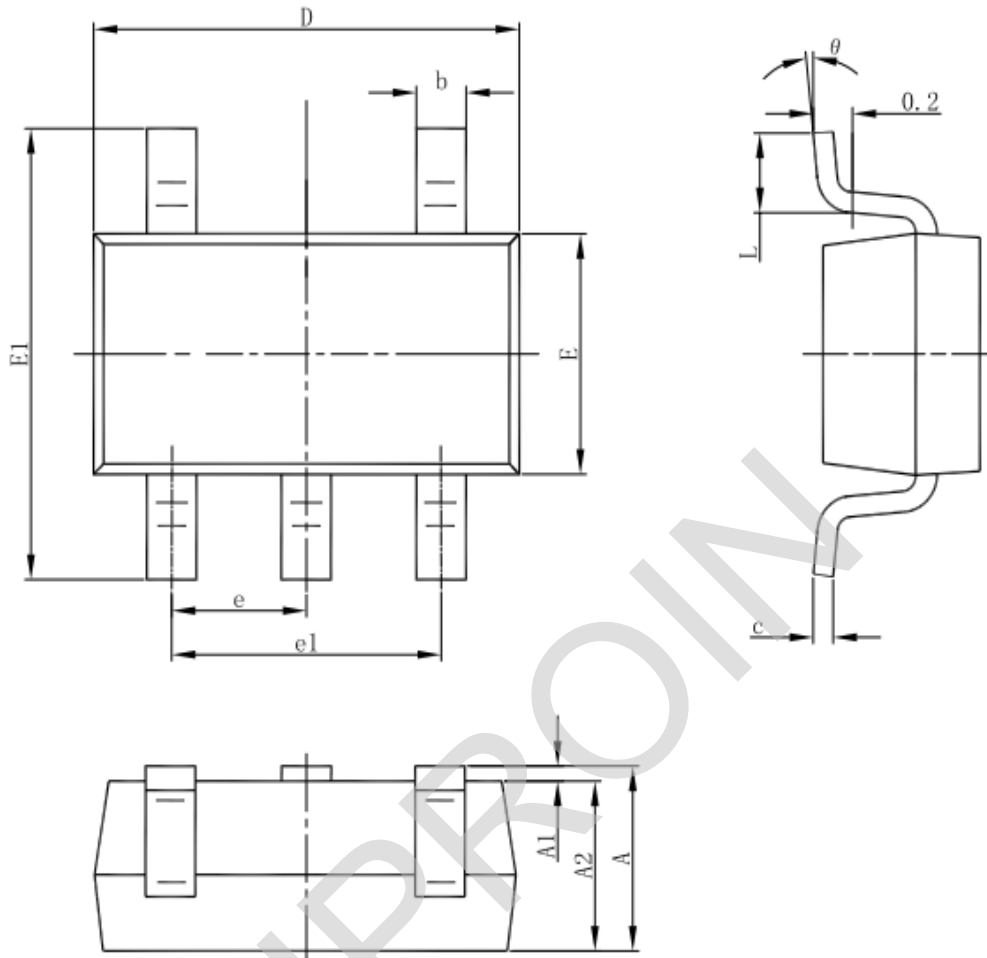

Symbol	Dimensions In Millimeters		Dimensions In Inches	
	Min	Max	Min	Max
A	1.050	1.250	0.041	0.049
A1	0.000	0.100	0.000	0.004
A2	1.050	1.150	0.041	0.045
b	0.300	0.500	0.012	0.020
c	0.100	0.200	0.004	0.008
D	2.820	3.020	0.111	0.119
E	1.500	1.700	0.059	0.067
E1	2.650	2.950	0.104	0.116
e	0.950(BSC)		0.037(BSC)	
e1	1.800	2.000	0.071	0.079
L	0.300	0.600	0.012	0.024
θ	0°	8°	0°	8°