

RoHS

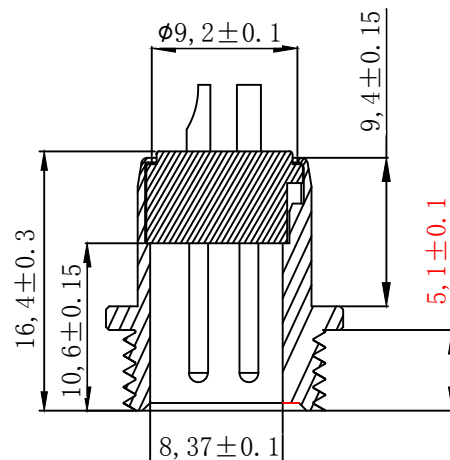
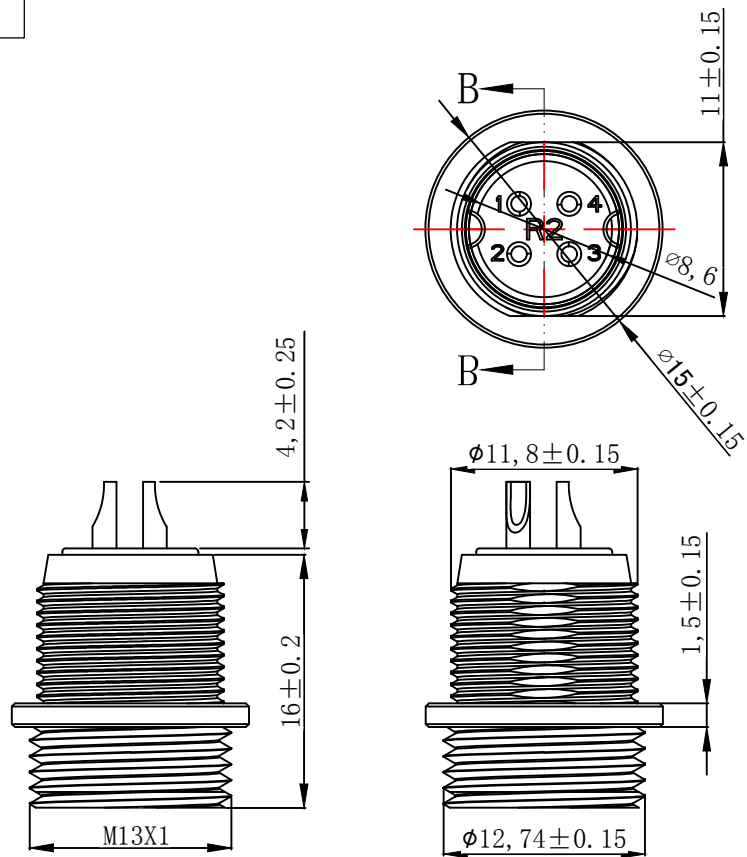

截面 B-B

检验要求

1. 所有尺寸均为重点检验尺寸,
2. 产品应无披锋、变形、气孔、缺浇等缺陷,
3. 不得有镀层脱落、开裂、等电镀不良, (重点卷边区域)
4. 铆压好之后公座胶芯不得有摇晃松动现象,
5. 六角螺母跟垫片装配是否顺畅,
6. 用通止规检验螺纹,

				OPERATION		DRAW	SCALE	FIT	深圳市连盛精密连接器有限公司		
				X.X	±0.30		UNIT	mm			
				X.XX	±0.20	CHECK	SIZE	A4			
				X.XXX	±0.10	APPROVE	SHEET	1/1	PART NO.	HKT-00006	
REV	DATE	MODIFICATION DESCRIPTION		CHANGE	DIM		TOL	PROJ.	◆	TITLE:	航空头 RY焊线12M-4P H5.8 PC4.2
1		2	3	4	5	6	7	8	9		