



PARA LIGHT ELECTRONICS CO., LTD.
4F, No.1, Lane 93, Chien Yi Road, Chung Ho City, Taipei, Taiwan
Tel: 886-2-2225-3733 Fax: 886-2-2225-4800
E-mail: para@para.com.tw <http://www.para.com.tw>

DATA SHEET

PART NO.: SZT2835KYCT

REV: A/0

CUSTOMER'S APPROVAL : _____

DCC : _____

DRAWING NO. : DS-31P-19-0225

DATE :2019-10-18

PAGE

1 of 9

● Benefits

- Low power consumption
- Available in various colors.
- Long life span (up to 30000hours)
- Soldering methods: IR reflow soldering and Hand soldering
- high brightness surface mount technology, for safe touch
- Emitting viewing angle 120°
- ROHS standard.

● Application

- Automotive
- Backlighting
- Decorative light
- Appliance light
- Sign and Channel Letter

● Mechanical dimension

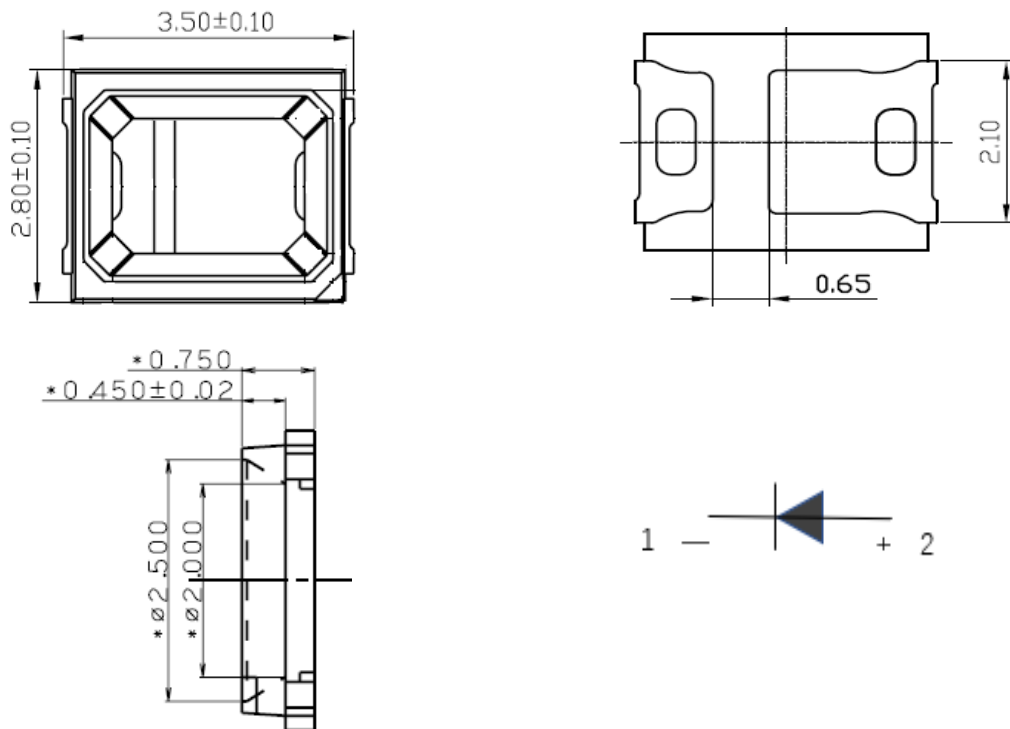

Notes:

1. All dimensions are in millimeters (inches).
2. Tolerance is ± 0.254 mm (0.01") unless otherwise specified.
3. Lead spacing is measured where the leads emerge from the package.
4. Specifications are subject to change with notice.

● **CHIP MATERIALS**

Dice Material : AlGaInP

Light Color : Yellow

Lens Color : Clear white

● **Absolute Maximum Ratings(Ta=25°C)**

Symbol	Parameter	Rating	Unit
PD	Power Dissipation	40	mW
IPF	Peak Forward Current (1/10 Duty Cycle, 0.1ms Pulse Width)	70	mA
IF	Continuous Forward Current	20	mA
VR	Reverse Voltage	5	V
Topr	Operating Temperature Range	-30 ~ + 80	°C
Tstg	Storage Temperature Range	-40 ~ + 100	°C
Tslid	Soldering Temperature (One times MAX.)	Reflow Soldering : 260 °C for 5 sec.	
		Hand Soldering : 350 °C for 3 sec	

pulse width <=0.1msec duty <=1/10

● **Electro-Optical Characteristics (Ta=25°C)**

Parameter	Symbol	Condition	Min.	Typ.	Max.	Unit
Forward Voltage	V _F	I _F = 20mA	1.9	---	2.3	V
Total Flux for white	IV	I _F =20mA	2	---	3	Lm
Dominant Wave Length	WLD	I _F = 20mA	590	---	595	nm
Reverse Current	I _R	V _R =5V	0	---	10	μA
View Angle	2θ _{1/2}	I _F =20mA	---	120	---	degree

- 1) Tolerance of measurement of luminous intensity is ±15%.
- 2) Tolerance of measurement of dominant wavelength is ±1nm.
- 3) Tolerance of measurement of Vf is ±0.05 V.



SURFACE MOUNT DEVICE LED

Part No. : SZT2835KYCT

REV: A/0

◆ Bin Intensity Bin Limits (At 20mA)

BIN CODE	Min(lm)	Max(lm)
A0	2	2.5
A1	2.5	3

◆ Bin VF Bin Limits (At 20mA)

BIN CODE	Min(v)	Max(v)
B	1.9	2.1
C	2.1	2.3

◆ Bin Color Bin Limits (At 20mA)

BIN CODE	Min(nm)	Max(nm)
6	590	595

● Package Dimensions Of Tape And Reel

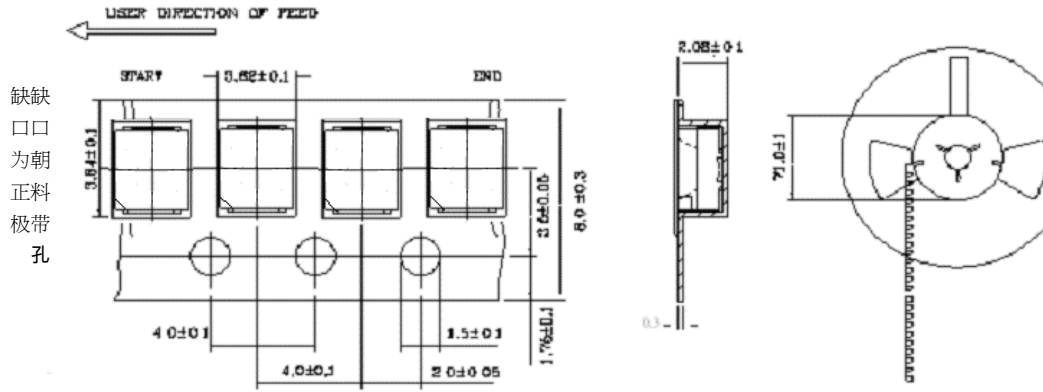

缺缺
口口
为朝
正料
极带
孔

Note: Tolerance unless mentioned is ± 0.1 mm; Unit = mm

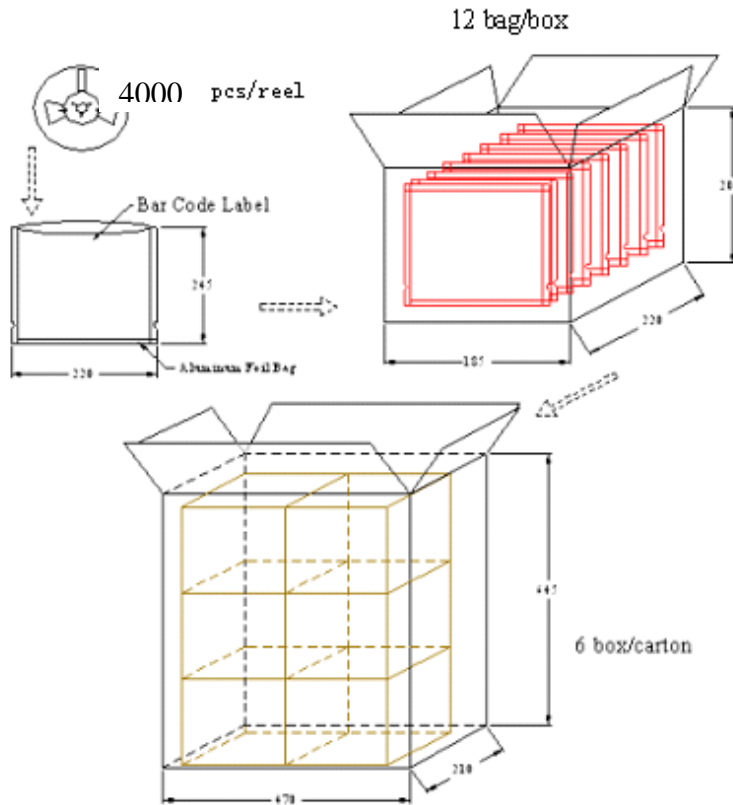

Carrier Tape Dimensions: Loaded Quantity 4000 pcs Per Reel.

● Label Explanation



● Recommended Soldering Pattern(unit:mm)

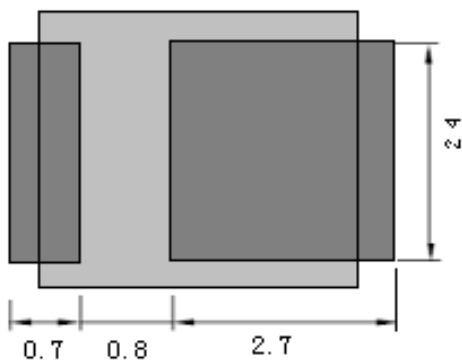
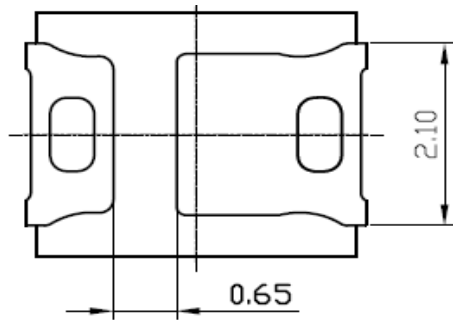

■ Solder resist
■ Solder paste stencil
Pad design for improved heat dissipation(Cu-area)

●Reliability Test

Classification	Test Item	Reference Standard	Test Conditions	Result
Endurance Test	Operation Life	MIL-STD-750:1026 MIL-STD-883:1005 JIS-C-7021 :B-1	I _F =40mA T _a =Under room temperature Test time=1,000hrs	0/20
	High Temperature High Humidity Storage	MIL-STD-202:103B JIS-C-7021 :B-11	T _a =+65°C±5°C RH=90%-95% Test time=168hrs	0/20
	High Temperature Storage	MIL-STD-883:1008 JIS-C-7021 :B-10	High T _a =+85°C±5°C Test time=1,000hrs	0/20
	Low Temperature Storage	JIS-C-7021 :B-12	Low T _a =-35°C±5°C Test time=1,000hrs	0/20
Environmental Test	Temperature Cycling	MIL-STD-202:107D MIL-STD-750:1051 MIL-STD-883:1010 JIS-C-7021 :A-4	-35°C ~ +25°C ~ +85°C ~ +25°C 60min 20min 60min 20min Test Time=5cycle	0/20
	Thermal Shock	MIL-STD-202:107D MIL-STD-750:1051 MIL-STD-883:1011	-35°C±5°C ~+85°C±5°C 20min 20min Test Time=10cycle	0/20
	Solder Resistance	MIL-STD-202:201A MIL-STD-750:2031 JIS-C-7021 :A-1	Preheating : 140°C-160°C, within 2 minutes. Operation heating : 260°C (Max.), within 10seconds. (Max.)	0/20

●Soldering :

1. Manual Soldering

The temperature of the iron tip should not be higher than 350°C and Soldering time to be within 3 seconds per solder-pad.

2. Reflow Soldering Temp/Time

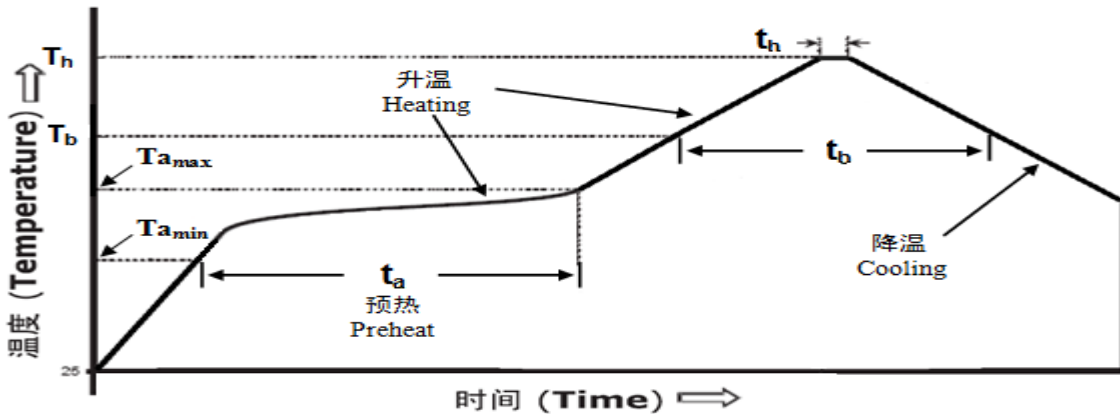

Temperature curve Parameters	Lead solder paste	Lead -free solder paste
The rate of temperature	4°C/SEC.MAX	4°C/SEC.MAX
Preheat : Min temperature (T_{amin})	100°C	120°C
Preheat : Max temperature (T_{amax})	150°C	180°C
Preheat time (t_{amin} to t_{amax})	60~100 SEC	60~120 SEC
Soldering temperature (T_b)	180°C	217°C
Soldering time (t_b)	60~120 SEC	60~120 SEC
Peak temperature	215°C	260°C
Peak temperature time	10 ~15 SEC	5~10 SEC
Cooling speed	6°C/SEC.MAX	6°C/SEC.MAX

● **Judgment criteria of failure for the reliability**

Measuring items	Symbol	Measuring conditions	Judgement criteria for failure
Forward voltage	V_F (V)	$I_F=40mA$	Over $U^1 \times 1.2$
Reverse current	$I_R(\mu A)$	$V_R=5V$	Over $U^1 \times 2$
Luminous intensity	I_v (mcd)	$I_F=40mA$	Below $S^1 \times 0.5$

Note: 1. U means the upper limit of specified characteristics. S means initial value.

2. After each test, remove test pieces, wait for 2 hours and test pieces have returned to ambient temperature, then take next measurement.

● **storage:**

1. recommended storage condition: At $5^{\circ}C-30^{\circ}C$ and relative humidity 60 % RH Max.

2. After this bag is opened, devices that will be applied to infrared reflow, vapor-phase reflow, or equivalent soldering process must be:

- a. completed within 24 hours
- b. Stored at less than 30% RH.

3. Devices require baking before mounting, if:

2a or 2b is not met.

4. If baking is required, devices must be baked under below conditions:

12 hours at $60^{\circ}C \pm 3^{\circ}C$

● **Note:**

(1) Care must be taken not to damage LED's silicone resin while exposing to high temperature or contact LED's silicone resin with hard or sharp objects, such as metal hook, tweezer or sand blasting..

(2) Current limiting resistor must be used in the circuit to drive Grand LEDs within the rated figures and not to overload Grand LEDs with instantaneous voltage at the turning ON and OFF cycles.

When using pulse driving, the average current must be within the rated figures. And the circuit should be designed to avoid reverse voltage when turning off the Grand LEDs.