

DATA SHEET

PART NO.: SZC170WZDT

REV: A / 0

CUSTOMER'S APPROVAL : _____

DCC : _____

DRAWING NO. : DS-72-18-0019G

DATE : 2018-12-15 PAGE

1 of 14

SURFACE MOUNT DEVICE LED

Part No. : SZC170WZDT

REV: A / 0

● PACKAGE OUTLINE DIMENSIONS

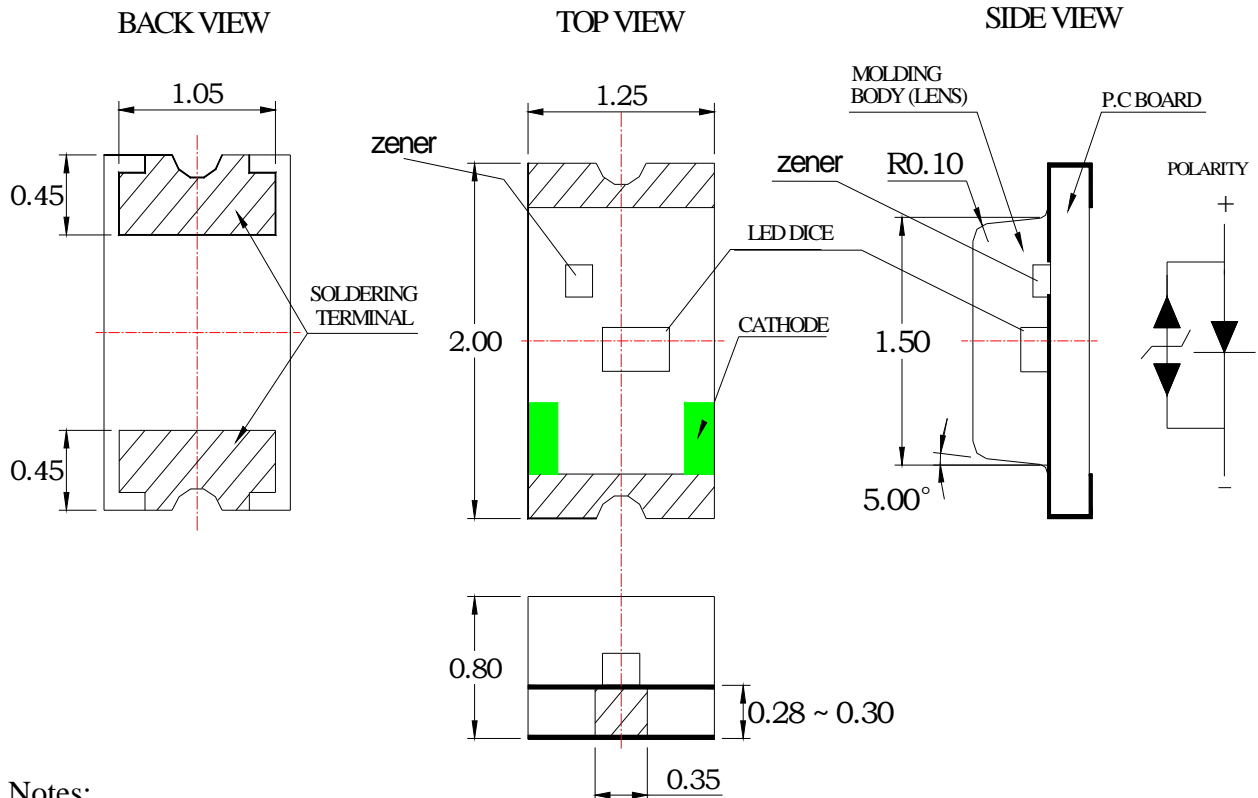

Notes:

1. All dimensions are in millimeters.
2. Tolerance is $\pm 0.1\text{mm}$ (.004") unless otherwise noted.

● Features

- * Wide view angle, White color SMD chip LED .
- * Compatible with automatic Pick & Place equipment.
- * Compatible with Reflow soldering and Wave soldering processes.
- * EIA STD package.(ANSI/EIA-481-B-2001)
- * I.C. compatible, low current application
- * Pb free product and acceptable lead-free process!.
- * Meet RoHS Green Product.

● Application

- * LCD back light
- * Switch back lights
- * Illuminations.

SURFACE MOUNT DEVICE LED

Part No. : SZC170WZDT

REV: A / 0

● CHIP MATERIALS

- * Dice Material : GaInN
- * Light Color : White
- * Lens Color : Light Yellow Diffused.

● Absolute Maximum Ratings(Ta=25°C)

| Symbol | Parameter | Rating | Unit |
|--------|--------------------------------------------------------------|------------|-------|
| PD | Power Dissipation | 100 | mW |
| IPF | Peak Forward Current (1/10 Duty Cycle, 0.1ms Pulse Width) | 80 | mA |
| IF | Continuous Forward Current | 20 | mA |
| - | De-rating Linear From 25°C | 0.25 | mA/°C |
| VR | Reverse Voltage | 5 | V |
| ESD | Electrostatic Discharge Threshold(HBM)Note A | 8000 | V |
| Topr | Operating Temperature Range | -40 ~+ 85 | °C |
| Tstg | Storage Temperature Range | -40 ~ + 85 | °C |

Note A :

HBM : Human Body Model. Seller gives no other assurances regarding the ability of to withstand ESD.

● Electro-Optical Characteristics(Ta=25°C)

| Parameter | Symbol | Min. | Typ. | Max. | Unit | Test Condition |
|--------------------|---------|--------|------|---------|------|----------------|
| Luminous Intensity | IV | 560 | | 1120 | mcd | IF=20mA |
| Viewing Angle | 2 θ 1/2 | | 130 | | Deg | Note 2 |
| CIE Chromaticity | X | 0.2804 | | 0.3135 | | IF=20mA |
| CIE Chromaticity | Y | 0.264 | | 0.32165 | | |
| Forward Voltage | VF | 2.8 | | 3.25 | V | IF = 20mA |
| Reverse Current | IR | | | 50 | μ A | VR = 5V |

SURFACE MOUNT DEVICE LED

Part No. : SZC170WZDT

REV: A / 0

● Bin Code List

| Luminous Intensity(IV), Unit:mcd@20mA | | |
|---------------------------------------|-----|------|
| Bin Code | Min | Max |
| U2 | 560 | 710 |
| V1 | 710 | 900 |
| V2 | 900 | 1120 |

Tolerance of each bin are $\pm 15\%$

| Forward Voltage(VF), Unit:V@20mA | | |
|----------------------------------|------|------|
| Bin Code | Min | Max |
| K8 | 2.8 | 2.95 |
| K9 | 2.95 | 3.1 |
| K10 | 3.1 | 3.25 |

Tolerance of each bin are ± 0.1 Volt

| Color Rank (CIE chromaticity X , Y) @ 20mA | | | | | | | | | |
|--------------------------------------------|---------|--------|--------|---------|----------|---------|--------|--------|---------|
| Rank A11 | | | | | Rank B11 | | | | |
| X | 0.2804 | 0.2884 | 0.2967 | 0.2888 | X | 0.2888 | 0.2967 | 0.3051 | 0.2972 |
| Y | 0.2735 | 0.2640 | 0.2793 | 0.29865 | Y | 0.28965 | 0.2793 | 0.2953 | 0.30565 |
| Rank C11 | | | | | | | | | |
| X | 0.2972 | 0.3051 | 0.3135 | 0.3056 | | | | | |
| Y | 0.30565 | 0.2953 | 0.3113 | 0.32165 | | | | | |

* Measurement of Color coordinates : ± 0.02

LC170WZDT

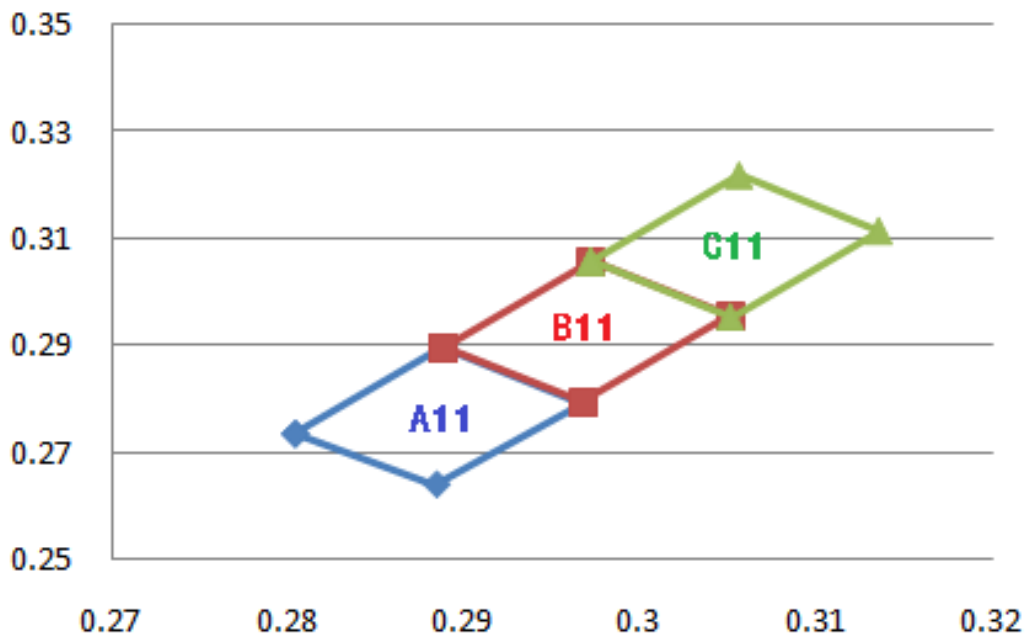

SURFACE MOUNT DEVICE LED

Part No. : SZC170WZDT

REV: A / 0

Notes:

1. Luminous intensity is measured with a light sensor and filter combination that proximates the CIE eye-response curve.
2. $\theta_{1/2}$ is the off-axis angle at which the luminous intensity is half the axial luminous intensity.
3. Caution in ESD :
Static Electricity and surge damages the LED. It is recommended use a wrist band or anti-electrostatic glove when handling the LED. All devices, equipment and machinery must be properly grounded.
4. Major standard testing equipment by "Instrument System" Model : CAS140B Compact Array Spectrometer and "KEITHLEY" Source Meter Model : 2400.

● Typical Electro-Optical Characteristics Curves

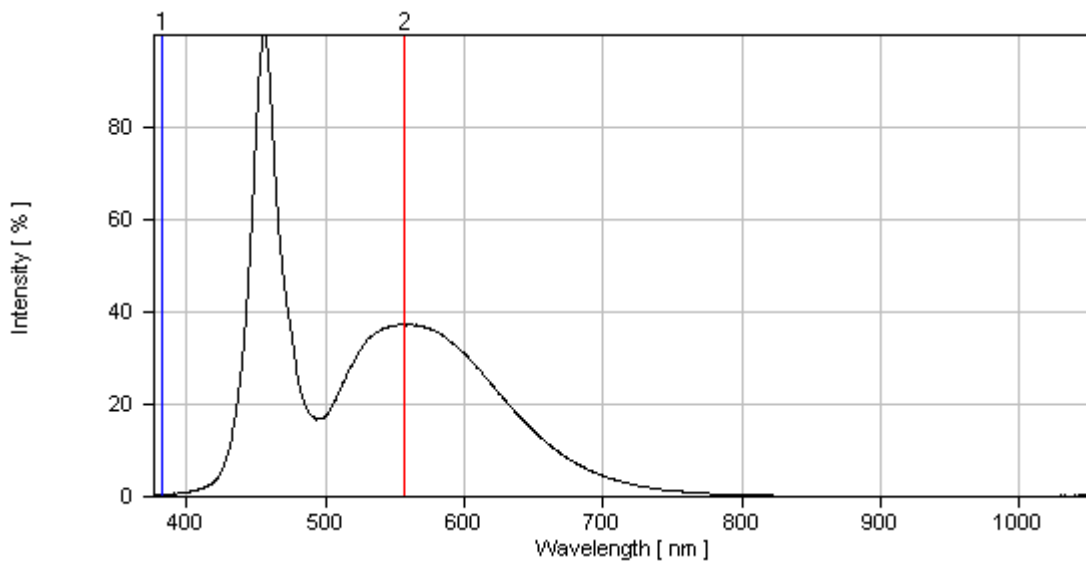

Fig.1 Relative Intensity vs. Wavelength

SURFACE MOUNT DEVICE LED

Part No. : SZC170WZDT

REV: A / 0

● Typical Electro-Optical Characteristics Curves

(25°C Ambient Temperature Unless Otherwise Noted)

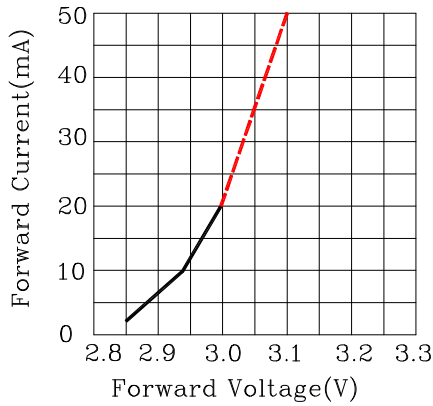

Fig.1 Forward Current vs. Forward Voltage

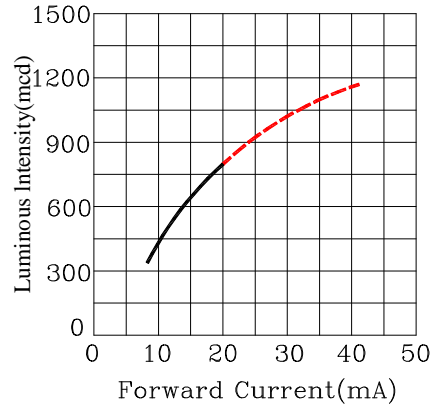

Fig.2 Luminous Intensity vs. Forward Current

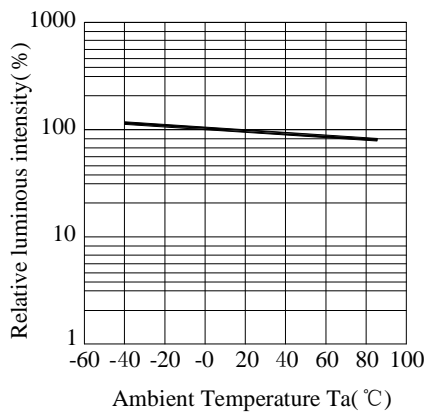

Fig.3 Luminous Intensity vs. Ambient Temperature

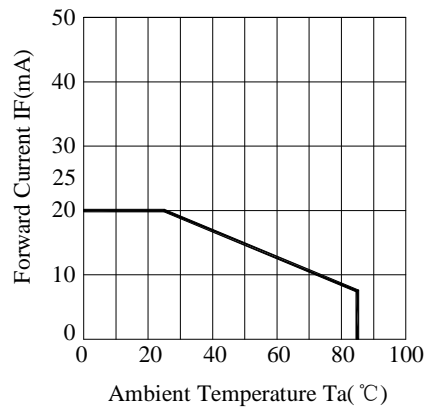

Fig.4 Forward Current Derating Curve

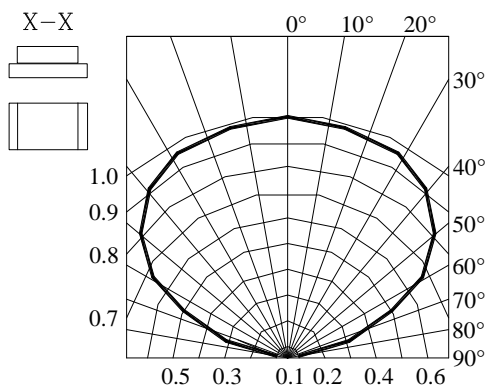

Fig.5 Relative Intensity vs. Angle

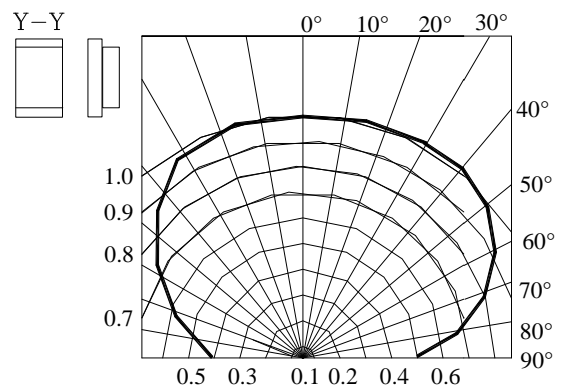

Fig.6 Relative Intensity vs. Angle

SURFACE MOUNT DEVICE LED

Part No. : SZC170WZDT

REV: A / 0

● Label Explanation

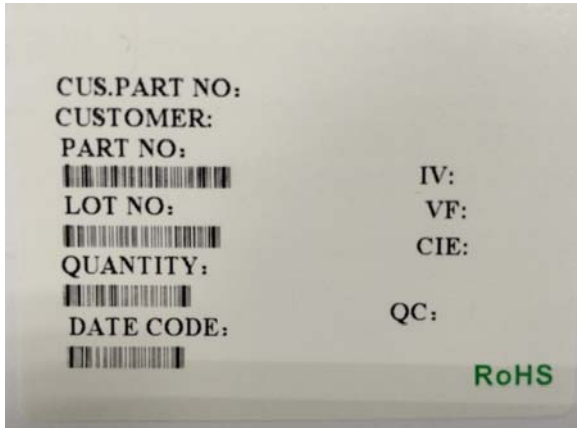

ITEM CODE:PARA LIGHT

PART NO: SZC170WZDT

IV --- Luminous Intensity Code

LOT NO: EM S L 12 09 0110
 A B C D E F

A---EM: Emos Code

B---S:SMD

L---Local

D---Year

E---Month

F---SPEC.

PACKING QUANTITY OF BAG :

3000pcs for 150、170、110、155、115 series

4000pcs for 191 series

5000pcs for 192 series

DATE CODE: 2012 09 10
 G H I

G--- Year

H--- Month

I --- Day

SURFACE MOUNT DEVICE LED

Part No. : SZC170WZDT

REV: A / 0

● Reel Dimensions

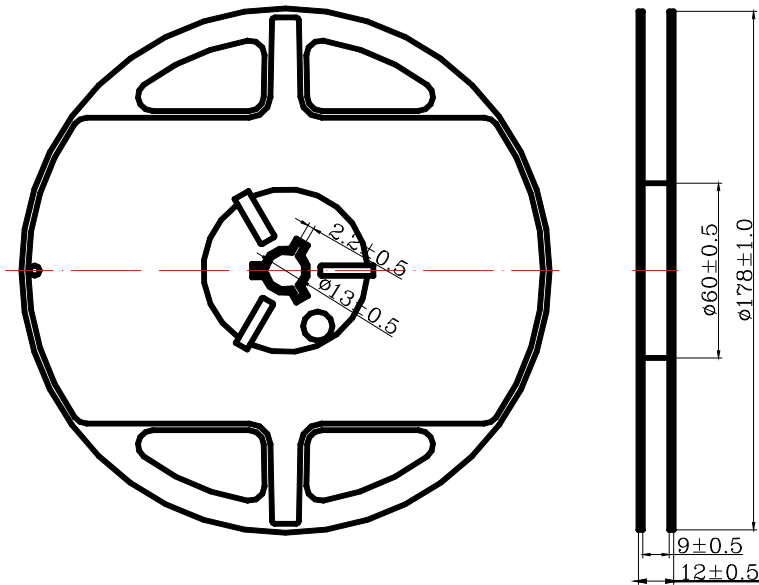

Notes:

1. Taping Quantity : 3000pcs
2. The tolerances unless mentioned is ± 0.1 mm, Angle $\pm 0.5^\circ$, Unit : mm.

SURFACE MOUNT DEVICE LED

Part No. : SZC170WZDT

REV: A / 0

● Package Dimensions Of Tape And Reel

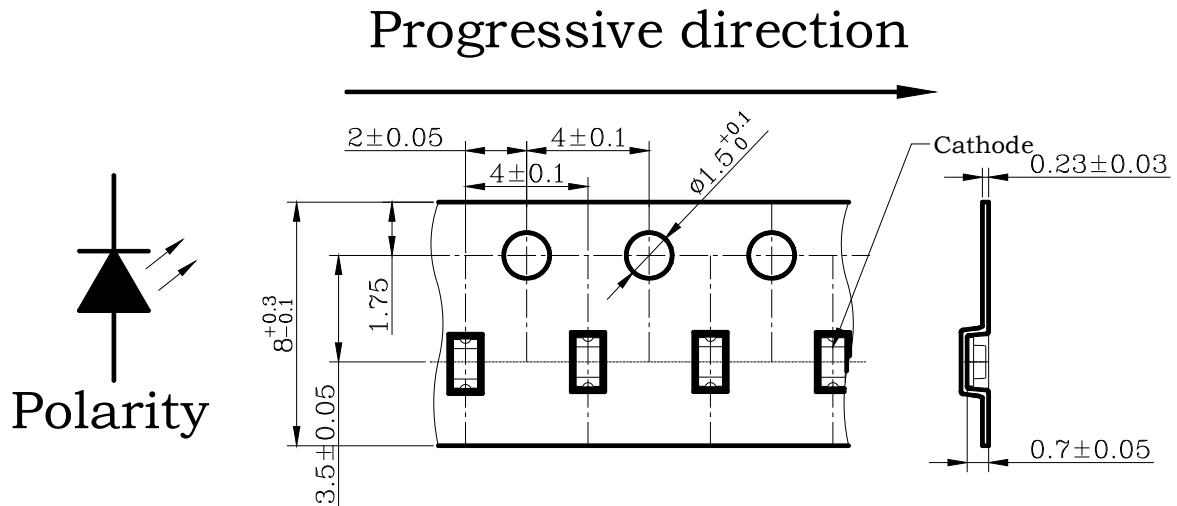

Notes: All dimensions are in millimeters.

● Cleaning

- * If cleaning is required, use the following solutions for less than 1 minute and less than 40°C.
- * Appropriate chemicals: Ethyl alcohol and isopropyl alcohol.
- * Effect of ultrasonic cleaning on the LED resin body differs depending on such factors as the oscillator output, size of PCB and LED mounting method. The use of ultrasonic cleaning should be enforced at proper output after confirming there is no problem.

● Suggest Soldering Pad Dimensions

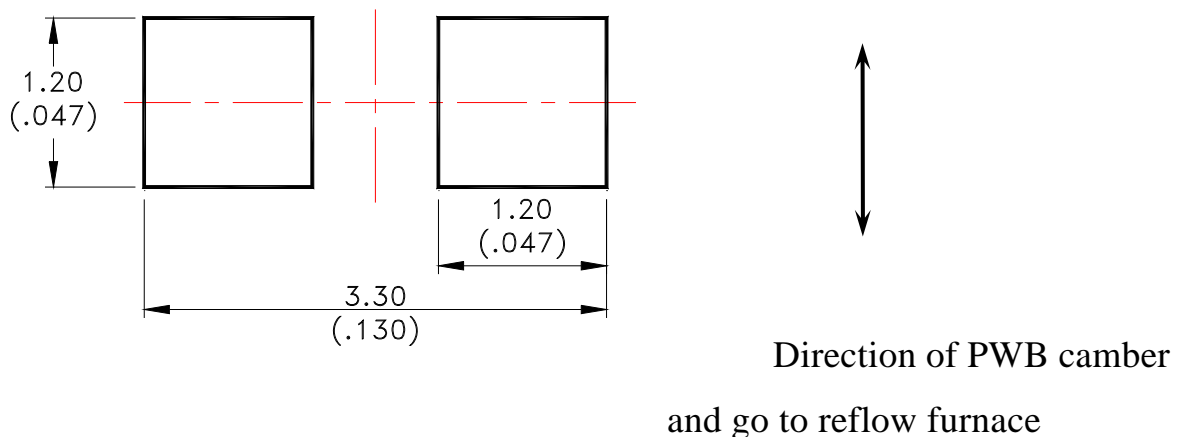

Notes : Suggest stencil print screen thickness are 0.10mm maximum.

SURFACE MOUNT DEVICE LED

Part No. : SZC170WZDT

REV: A / 0

● Suggest Sn/Pb IR Reflow Soldering Profile Condition:

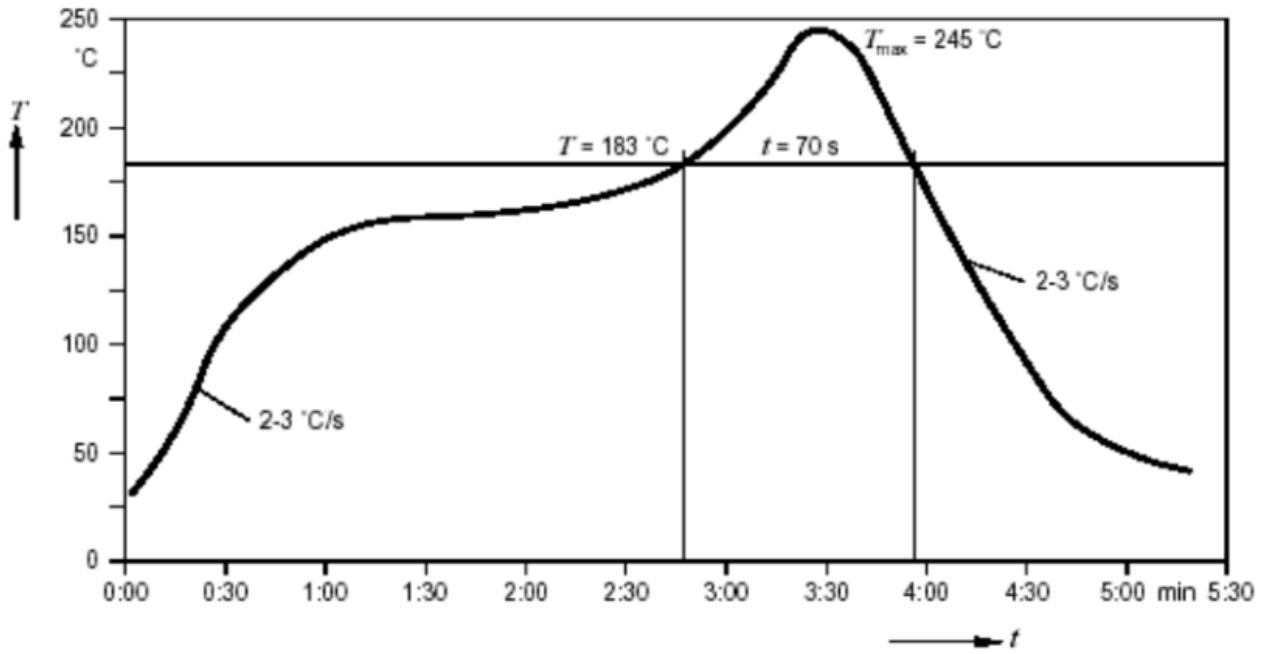

● Suggest Pb-Free IR Reflow Soldering Profile Condition:

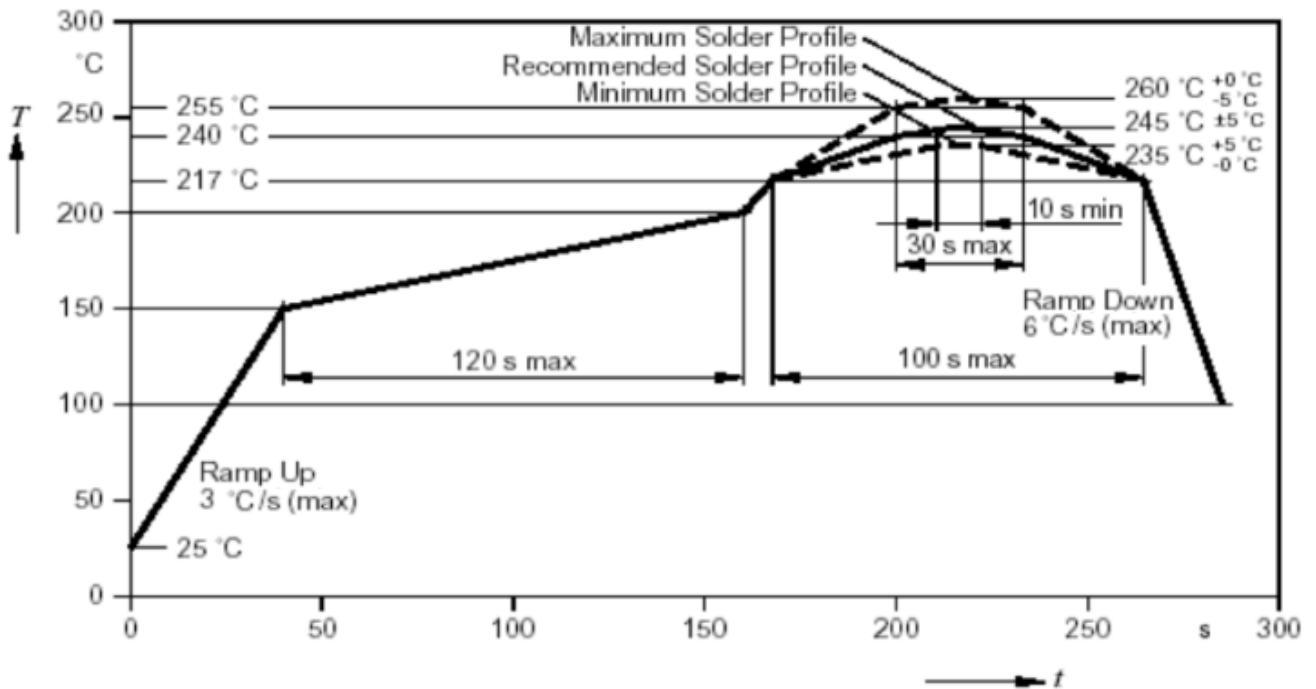

SURFACE MOUNT DEVICE LED

Part No. : SZC170WZDT

REV: A / 0

● CAUTIONS

1.Application Limitation :

The LED's described here are intended to be used for ordinary electronic equipment(such as office equipment, communication equipment and household application).Consult PARA's sales in advance for information on application in which exceptional quality and reliability are required, particularly when the failure or malfunction of the LED's may directly jeopardize life or health (such as airplanes, automobiles, traffic control equipment, life support system and safety devices).

2.Storage :

Do not open moisture proof bag before the products are ready to use.

Before opening the package: The LEDs should be kept at 30°C or less and 90%RH or less.

After opening the package: The LED's floor life is 1 year under 30°C or less and 60% RH or less. If unused LEDs remain, it should be stored in moisture proof packages.

If the moisture absorbent material (silica gel) has faded away or the LEDs have exceeded the storage time, baking treatment should be performed using the following conditions.

Baking treatment: 60±5°C for 24 hours.

3.Soldering

Do not apply any stress to the lead frame during soldering while the LED is at high temperature.

Recommended soldering condition.

Reflow Soldering :

Pre-heat 120~150°C, 120sec. MAX., Peak temperature : 240°C Max. Soldering time : 10 sec Max.

Soldering Iron : (Not recommended)

Temperature 300°C Max., Soldering time : 3 sec. Max.(one time only), power dissipation of iron : 20W Max. use SN60 solder of solder with silver content and don't to touch LED lens when soldering.

Wave soldering :

Pre-heat 100°C Max, Pre-heat time 60 sec. Max, Solder wave 260°C Max, Soldering time 5 sec. Max. performed consecutively cooling process is required between 1st and 2nd soldering processes.

SURFACE MOUNT DEVICE LED

Part No. : SZC170WZDT

REV: A / 0

4. Lead-Free Soldering

For Reflow Soldering :

- 1、Pre-Heat Temp: 150-180°C,120sec.Max.
- 2、Soldering Temp: Temperature Of Soldering Pot Over 230°C,40sec.Max.
- 3、Peak Temperature: 260°C , 5sec.
- 4、Reflow Repetition: 2 Times Max.
- 5、Suggest Solder Paste Formula : 93.3 Sn/3.1 Ag/3.1 Bi/0.5 Cu

For Soldering Iron (Not Recommended) :

- 1、Iron Tip Temp: 350°C Max.
- 2、Soldering Iron: 30w Max.
- 3、Soldering Time: 3 Sec. Max. One Time.

For Dip Soldering :

- 1、Pre-Heat Temp: 150°C Max. 120 Sec. Max.
- 2、Bath Temp: 265°C Max.
- 3、Dip Time: 5 Sec. Max.

5. Drive Method

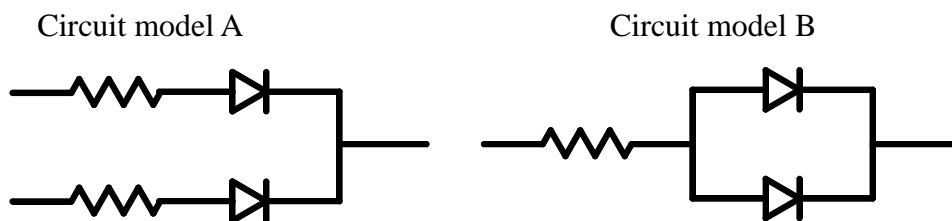

(A)Recommended circuit.

(B)The difference of brightness between LED`s could be found due to the Vf-If characteristics of LED.

SURFACE MOUNT DEVICE LED

Part No. : SZC170WZDT

REV: A / 0

6. Reliability Test

| Classification | Test Item | Test Condition | Reference Standard |
|--------------------|----------------------------------------|--------------------------------------------------------------------------------------------------------------------|---------------------------------------------------------------------------------------------------------------------------|
| Endurance Test | Operation Life | Ta= Under Room Temperature As Per Data Sheet Maximum Rating *Test Time= 1000HRS (-24HRS,+72HRS)*@20mA. | MIL-STD-750D:1026 (1995) MIL-STD-883D:1005 (1991) JIS C 7021:B-1 (1982) |
| | High Temperature High Humidity Storage | IR-Reflow In-Board, 2 Times Ta= 65±5°C, RH= 90~95% *Test Time= 1000HRS±2HRS | MIL-STD-202F:103B(1980) JIS C 7021:B-11(1982) |
| | High Temperature Storage | Ta= 105±5°C Test Time= 1000HRS (-24HRS,72HRS) | MIL-STD-883D:1008 (1991) JIS C 7021:B-10 (1982) |
| | Low Temperature Storage | Ta= -55±5°C *Test Time=1000HRS (-24HRS,72H RS) | JIS C 7021:B-12 (1982) |
| Environmental Test | Temperature Cycling | 105±5°C -55±5°C 10mins 10mins 100 Cycles | MIL-STD-202F:107D (1980) MIL-STD-750D:1051(1995) MIL-STD-883D:1010 (1991) JIS C 7021:A-4(1982) |
| | Thermal Shock | IR-Reflow In-Board, 2 Times 105±5°C -55°C±5°C 10mins 10mins 100 Cycles | MIL-STD-202F:107D(1980) MIL-STD-750D:1051(1995) MIL-STD-883D:1011 (1991) |
| | Solder Resistance | Tsol= 260 ± 5°C Dwell Time= 10 ± 1sec | MIL-STD-202F:210A(1980) MIL-STD-750D:2031(1995) JIS C 7021:A-1(1982) |
| | Solder ability | Tsol= 235 ± 5°C Immersion time 2±0.5 sec Immersion rate 25±2.5 mm/sec Coverage ≥95% of the dipped surface | MIL-STD-202F:208D(1980) MIL-STD-750D:2026(1995) MIL-STD-883D:2003(1991) IEC 68 Part 2-20 JIS C 7021:A-2(1982) |

7. Others:

The appearance and specifications of the product may be modified for improvement without notice.

SURFACE MOUNT DEVICE LED

Part No. : SZC170WZDT

REV: A / 0

● PART NO. SYSTEM :

SZ C 1 7 0 X C X X - X X X X

XXXX : Special specification for customer

T : Taping for 7 inch reel
TC : Taping for 13 inch reel
TH : IV half binning
TP : Wavelength binning

Lens color
C : Water Clear
W : White Diffused
T : Color Transparent
D : Color Diffused

KG : AlInGap 570nm Super Green
KY : AlInGap 590nm Super Yellow
KF : AlInGap 605nm Super Amber
KR : AlInGap 630 nm Super Red
LB : InGaN 470nm Blue
LG : InGaN 525nm Green
W : InGaN + YAG White

0 : Single chip
1/2 : Super thin single chip
5/6 : Dual chip
F : Three chip(Full color)

150 : 1206 1.1T Type
170 : 0805 0.8T Type
191 : 0603 0.6T Type
192 : 0603 0.4T Type
110 : 1206 1.0T Type

C : Top View Type
S : Side View Type