

ROHS

NOTE:

- 1.MATERIAL SPECIFICATION:
 - 1.HOUSING:LCP COLOR SEE TABLE 1,UL94 V-0.
 - 2.CONTACTS:COPPER ALLOY(C1814)
 - 3.MID PLATE&SPRING: STAINLESS STEEL(SUS301)
 - 4.FRONT SHELL&COVER: STAINLESS STEEL(SUS304)
- 2.PLATING SPECIFICATION:
 - 2-1.CONTACTS:
 - Ni 50u" MIN. UNDER PLATED OVER ALL.
 - Au PLATED ON THE FUNCTIONAL AREA OF CONTACT.
 - (GOLD PLATING THICKNESS FOLLOW THE P/N)
 - PLATING SPECIFICATIONS OF THE SOLDER AREA FOLLOW THE P/N
 - 2-2.FRONT SHELL & COVER:
 - Ni 30u" MIN. UNDER PLATED OVER ALL.
 - 2-3.MID PLATE & EMI SPRING:
 - CLEAR ONLY
- 3.MECHANICAL PERFORMANCE,
 - 3-1.INSERTION FORCE: 0.5~2.0kgf.
 - 3-2.REMOVAL FORCE: 0.8kgf~2.0kgf.
 - 3-3.DURABILITY: 10000 CYCLES.
- 4.ELECTRICAL PERFORMANCE,
 - 4-1. CURRENT RATING:3.0A
VOLTAGE RATING:5.0V
 - 4-2. LLCR:
 - VBUS & GND PINS AND OTHER PINS: 40mΩ/PIN MAX.
 - SHIELD: 50mΩ/MAX.
 - LLCR MAX. CHANGE OF ALL PINS: 10mΩ.
 - 4-3.INSULATION RESISTANCE: 100MΩ MIN
 - 4-4.DIELECTRIC WITHSTAND VOLTAGE,AC 100V FOR 1 MINUTE.
5. ENVIRONMENTAL PERFORMANCE:
 - OPERATING TEMPERATURE: -25°C~+85°C.
- 6.IR REFLOW:
 - THE PEAK TEMPERATURE ON THE BOARD SHALL BE MAINTAINED FOR 10 SECONDS AT 260°C.

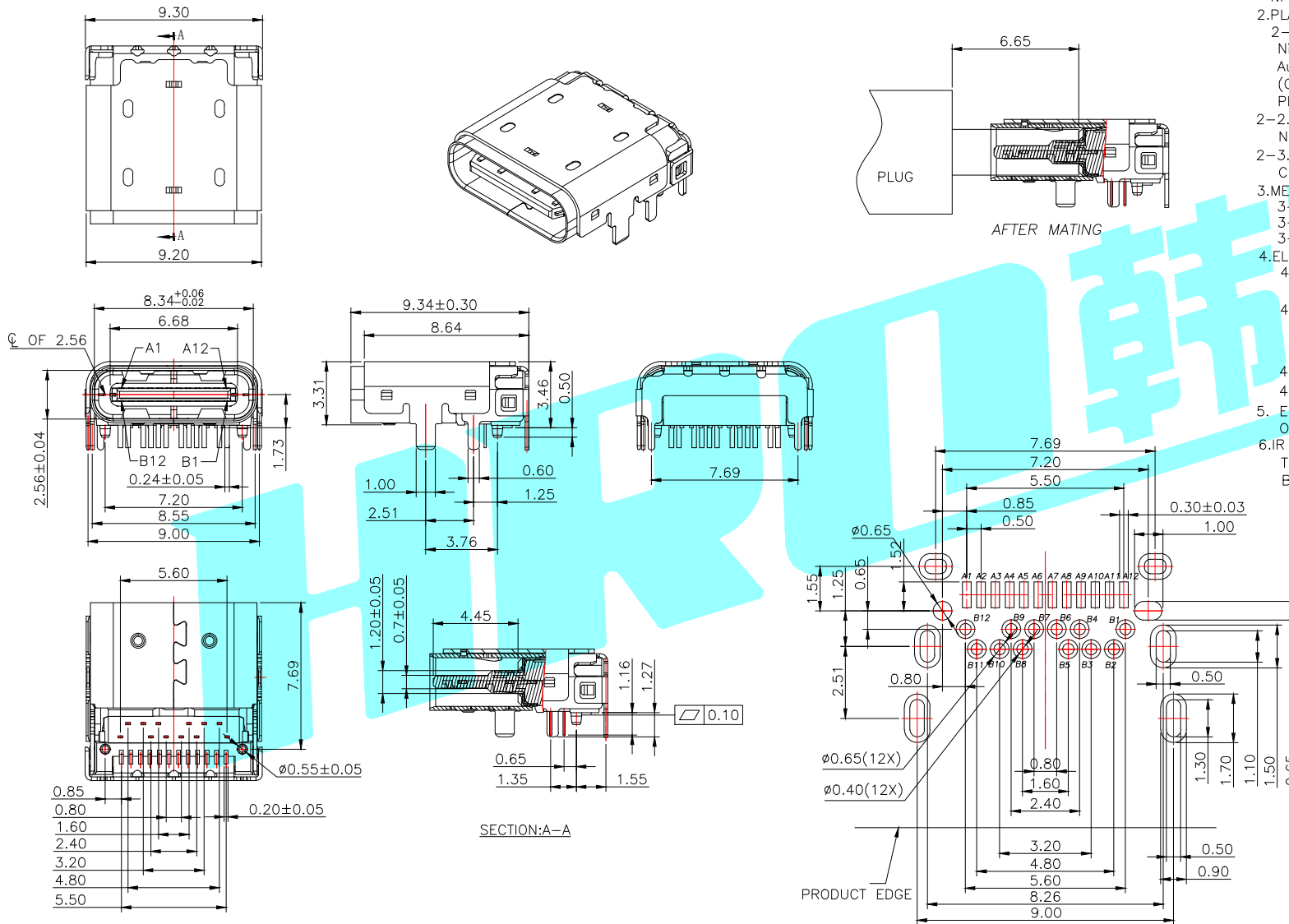

PIN	SIGNAL NAME	PIN	SIGNAL NAME
A1	GND	B12	GND
A2	SSTXp1	B11	SSRXp1
A3	SSTXn1	B10	SSRXn1
A4	Vbus	B9	Vbus
A5	CC1	B8	SBU2
A6	Dp1	B7	Dn2
A7	Dn1	B6	Dp2
A8	SBU1	B5	CC2
A9	Vbus	B4	Vbus
A10	SSRXn2	B3	SSTXn2
A11	SSRXp2	B2	SSTXp2
A12	GND	B1	GND

SCALE 1.5:1
 RECOMMENDED PCB LAYOUT(TOP VIEW)
 THICKNESS 1.0 MM;DEFAULT TOLERANCE:±0.05

APPROVALS		DATE	HRO 皓霖® ELECTRONICS CO.,LTD		
DRAWN	LIUCAN	2021.6.29	TITLE:	USB CONNECTOR	
CHECKED			PART NO.	TYPE-C-31-M-34	
APPROVALS			UNIT: mm	SCALE: 1:1	PROJ:
TOLERANCES ARE	30~以上 ±0.30	ANGLE	DRAWING NO.		SHEET 1 OF 1
	10~30 ±0.25	±2'			
	5~10 ±0.20				
	~ 5 ±0.15				

ECN NO.	REV.	DATE.	DESCRIPTION.	CHANGE.	CHECK.	APPRO.
	A		NEW			