

# 承認書

## SPECIFICATION FOR APPROVAL

CUSTOMER: \_\_\_\_\_ 2144 \_\_\_\_\_

DESCRIPTION: \_\_\_\_\_ COMMON MODE CHOKE \_\_\_\_\_

DDY PART NO: \_\_\_\_\_ WBA0805D900PT-G4-HF \_\_\_\_\_

CUSTOMERMODELNO: \_\_\_\_\_

DRAWING		
MADE	CHECKED	APPROVED
聂旭彬	黄志伟	陈启善
DATE:	2021年11月15日	

CUSTOMER APPROVE

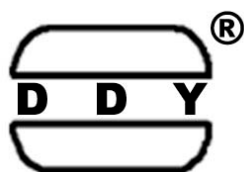

惠州市德立电子有限公司  
HUI ZHOU DE LI ELECTRONICS CO., LTD

廣東省博羅縣洲際工業園梅園三路  
NO.3 MEI YUAN ROAD, ZHOU JI INDUSTRIAL AREA, BOLUO COUNTY GUANGDONG

電話：0752-6207968      0752-6207962

傳真：0752-6207969

郵編：516100

Http://ddycoils.com



惠州市德立电子有限公司

HUIZHOU DELI ELECTRONICS CO., LTD

CUSTOMER:	2144	REV NO:	A1.0
DESCRIPTION:	COMMON MODE CHOKE	PAGE NO:	PAGE 1 OF 6
PART NO:	WBA0805D900PT-G4-HF	SN.	
CUSTOMER NO:		DATE:	2021年11月15日

## CATALOG

Resume .....	P2
Shape & Dimension .....	P3
Characteristic .....	P3
Part numbering system .....	P3
General specification .....	P3
Soldering Conditions .....	P4
Material List .....	P4
Package Information .....	P5
Electrical Characteristic Curve .....	P6





# 惠州市德立电子有限公司

## HUIZHOU DELI ELECTRONICS CO., LTD

CUSTOMER:	2144	REV NO:	A1.0
DESCRIPTION:	COMMON MODE CHOKE	PAGE NO:	PAGE 3 OF 6
PART NO:	WBA0805D900PT-G4-HF	SN.	
CUSTOMER NO:		DATE:	2021年11月15日

### 1. SHAPE & DIMENSION

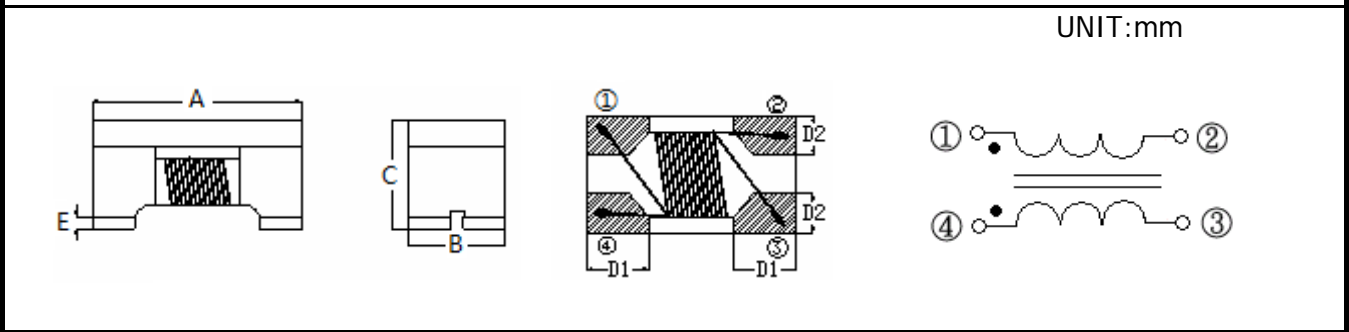

CODE	A	B	C	D1	D2	E	
DIMENSION	2.0±0.2	1.2±0.2	1.2±0.2	0.55Typ.	0.46Typ.	0.2±0.1	

### 2. ELECTRICAL CHARACTERISTICS @25°C

Part Number	Z	Freq	Rdc	Irms	Rated Voltage	Min Insulation Resistance
	(Ω)	(MHz)	(Ω)max	(mA)max	Volts	MΩ
WBA0805D900PT-G4-HF	90	100	0.35	400	50	10

### 3. PART NUMBERING SYSTEM

<b>WBA</b>	□	□	□	□	□	□	—	□	□	—	□	□
<b>1</b>	<b>2</b>	<b>3</b>	<b>4</b>	<b>5</b>	<b>6</b>			<b>7</b>			<b>8</b>	

- 1 PRODUCT SYMBOL (产品代号)
- 2 DIMENSIONS (规格尺寸)
- 3 MATERIAL (芯片类型)
- 4 IMPEDANCE (阻抗)
- 5 TOLERANCE (公差) : P±25%; N±30%
- 6 PACKAGING (包装方式) : T-编带盘装; B-散装
- 7 IDENTIFICATION CODE(标识码): 无则缺省此项.
- 8 E.P. (环保) : LF—Lead Free HF—Halogen Free FP—Red Phosphor Free

### 4. GENERAL SPECIFICATION

- a. Rating DC current: Temperature rise(ΔT) is 40°C approximately at I<sub>rms</sub>.
- b. Operating temp.: -40°C ~ +85°C
- c. Storage temp.: -10°C ~ +40°C R.H.: 65% Max
- d. Moisture sensitivity level (MSL) 2 (1 year floor life at <30°C/65% relative humidity)

APPROVED BY	CHECKED BY	DRAFT
陈启善	黄志伟	聂旭彬

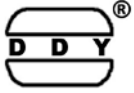

CUSTOMER:	2144	REV NO:	A1.0
DESCRIPTION:	COMMON MODE CHOKE	PAGE NO:	PAGE 4 OF 6
PART NO:	WBA0805D900PT-G4-HF	SN.	
CUSTOMER NO:		DATE:	2021年11月15日

**5. SOLDERING CONDITIONS**

**Figure 1.**  
**Re-flow Soldering (Lead Free)**

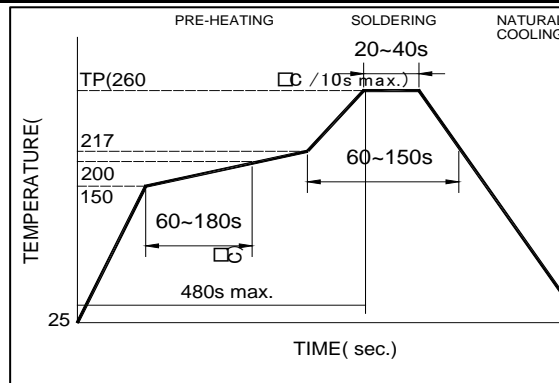

Note:

**Figure 2.**  
**Hand Soldering**

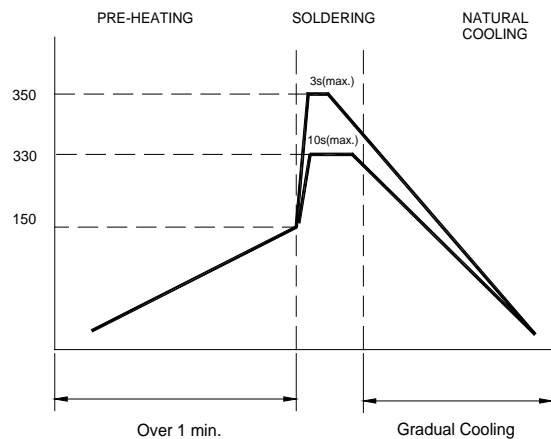

Note:

- Use a 20 watt soldering iron with tip diameter of 1.0mm
- Limit soldering time to 3 sec.

**6.MATERIAL LIST**

NO	DESCRIPTION	DESCRIPTION	SUPPLIER
1	Upper Plate	Ferrite	KOKUSUN Or equivalent
2	Core	Ferrite Core	KOKUSUN Or equivalent
3	Wire	Enameled Copper Wire	Elektrisola Or equivalent

REMARK:

APPROVED BY	CHECKED BY	DRAWN BY
陈启善	黄志伟	聂旭彬

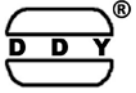

惠州市德立电子有限公司

HUIZHOU DELI ELECTRONICS CO., LTD

CUSTOMER:	2144	REV NO:	A1.0
DESCRIPTION:	COMMON MODE CHOKE	PAGE NO:	PAGE 5 OF 6
PART NO:	WBA0805D900PT-G4-HF	SN.	
CUSTOMER NO:		DATE:	2021年11月15日

7. PACKAGING(unit: mm)

Type	0805
Quantity	2000

TAPING DRAWINGS

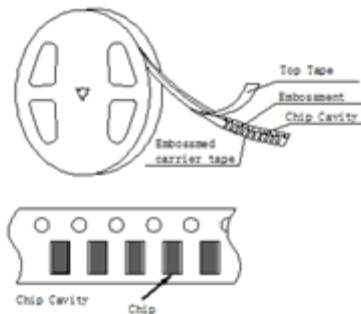

REEL DIMENSIONS(UNIT:mm)

	A	B	C	N	G
CF-8	178±2.0	22±2.0	12.5±1.5	57±2.0	8

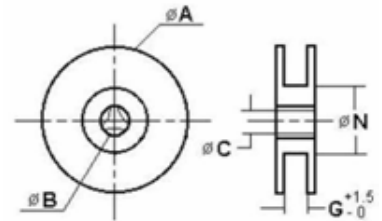

LEADER AND BLANK PORTION

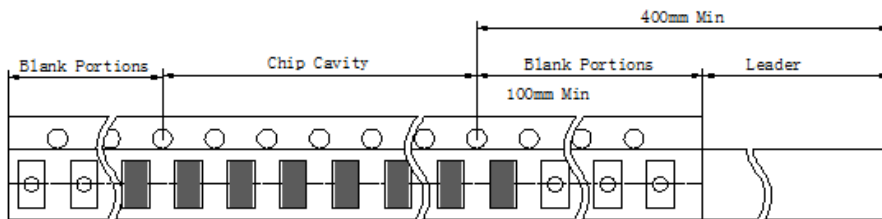

PEELLING OFF FORCE:0.05 to 0.7N in the direction show below.

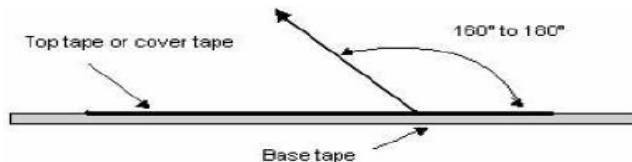

注意:

此物料不涉及汽车或相关产品方面的应用，否则，由此引起的一切品质和责任问题，我司将概不承担。

APPROVED BY	CHECKED BY	DRAFT
陈启善	黄志伟	聂旭彬



惠州市德立电子有限公司

HUIZHOU DELI ELECTRONICS CO., LTD

CUSTOMER:	2144	REV NO:	A1.0
DESCRIPTION:	COMMON MODE CHOKE	PAGE NO:	PAGE 6 OF 6
PART NO:	WBA0805D900PT-G4-HF	SN.	
CUSTOMER NO:		DATE:	2021年11月15日

### 8.ELECTRICAL CHARACTERISTIC CURVE

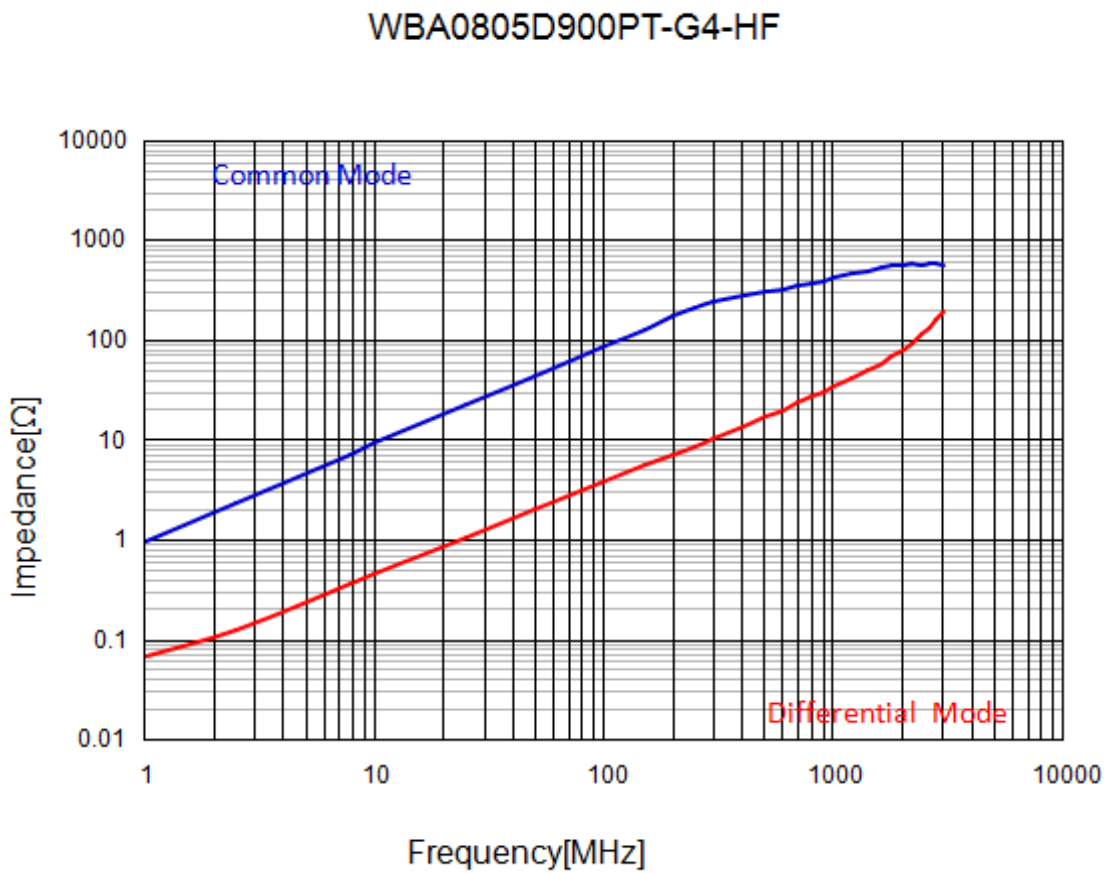

APPROVED BY	CHECKED BY	DRAFT
陈启善	黄志伟	聂旭彬