

LEFT SIDE VIEW

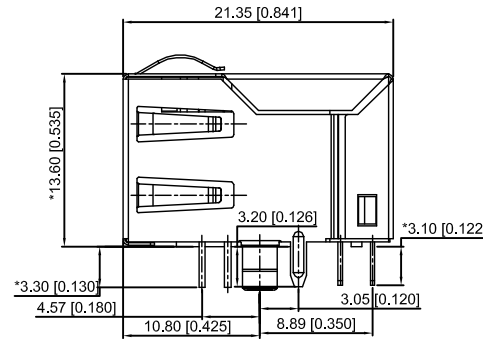

RIGHT SIDE VIEW

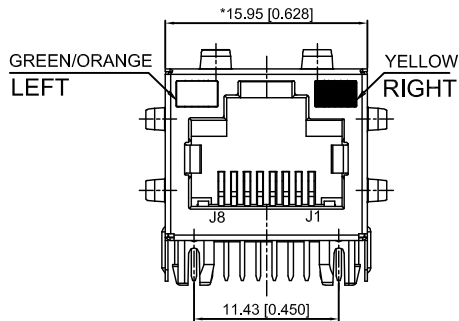

FRONT VIEW

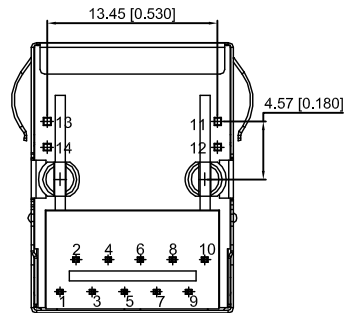

BOTTOM VIEW

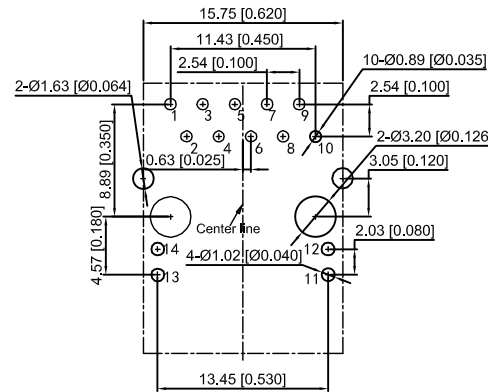

RECOMMENDED PCB LAYOUT VIEWED FROM COMPONENT SIDE

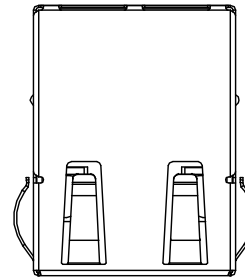

TOP VIEW

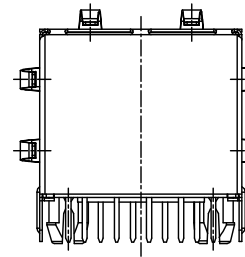

BACK VIEW

Electrical 电气:

- Turn ratio 匝数比: 1~2: J1~J2=1CT:1CT(±2%), 3~4: J3~J6=1CT:1CT(±2%), 7~8: J4~J5=1CT:1CT(±2%), 9~10: J7~J8=1CT:1CT(±2%)
- OCL: 350uH Min. at 100KHz 100mV 8mA DC.
- Insertion Loss 插入损耗: -1.0 dB Max 1~100MHz.
- Return loss 回波损耗: -18dB Min 1~30MHz, -14dB Min 30~60MHz, -12dB Min 60~80MHz, -10dB Min 80~100MHz.
- Cross talk: -40dB Min 1~30MHz, -35dB Min 30~60MHz, -30dB Min 60~100MHz.
- CMR: -30dB Min 1~100MHz.
- Hi-Pot: 2250V DC 6S 1mA PRI TO SEC.

LED Specification

Standard LED Color	LED Wavelength	Forward Current	Forward Voltage
Green	565nm	20mA	1.85~2.45V
Yellow	595nm	20mA	1.7~2.2V
Orange	595nm	20mA	1.85~2.45V

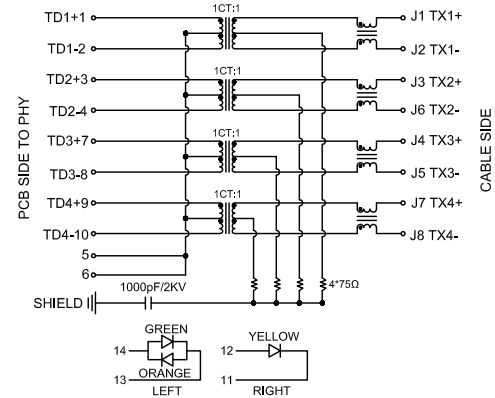

XKB Connectivity

MATERIAL 材料:

- HOUSING : PBT, UL94V-0, BLACK.
- TERMINALS BRACKET 端子支架: PBT, UL94V-0, BLACK.
- SHIELD 保护物: C2680, T=0.20MM, NICKEL PLATING ON ALL AREA.
- TERMINAL 端子: PHOSPHOR BRONZE C5210, T=0.35MM, GOLD PLATING ON CONTACT AREA.

MECHANICAL 机械:

- DURABILITY 耐用性: 750 CYCLES MIN.
- MATING FORCE 配合力: 23N MAX.
- OPERATING TEMPERATURE 工作温度: -40°C~+85°C.
- STORAGE TEMPERATURE 储存温度: -40°C~+85°C.
- ALL CRITICAL DIMENSIONS WITH "★"

DSND		DATE		SCALE: N/A	MODEL TYPE: RJ JACK
DWN		DATE		VIEW:	PART NO.:
CHKD		DATE		UNIT: mm/in	DWG NO.:
APPD		DATE		SIZE: A4	X02AQ070FF5DDZ
				XKB INDUSTRIAL PRECISION CO., LIMITED	WEIGHT 1.0g
					SHEET 1/1
					REVISION A0

ΔX					ANGLAR ±5°
ΔX					L ≤ 4 ±0.2
ΔX					4 < L ≤ 16 ±0.3
MARK	DESCRIPTION	DATE	REVISED	APPROVED	16 < L ≤ 63 ±0.4
	REVISIONS				L > 63 ±0.5
	www.xk-dg.cn www.helloxkb.com www.helloxkb.cn				UNSPECIFIED TOLERANCES