

250 mA Low Noise and Low Supply Current LDO Regulator

No.EA-508-210427

OVERVIEW

The RP123x is an LDO regulator that provides low output noise, high ripple rejection and fast response characteristics, achieved by low supply current. This device is suitable not only for noise-sensitive applications such as high-performance analog circuits, but also for various applications.

KEY BENEFITS

- Achieves Low Noise, High PSRR and Fast Response.
- Provides Saving Space by Adopting of 4-pin Small Package without Noise Bypass Capacitor.
- Provides Long-Duration of Operation for Battery-powered Equipment by Low Supply Current of 9.5 μA (Typ.), despite the low-noise LDO.

KEY SPECIFICATIONS

- Input Voltage Range (Max.Rating): 1.9 V to 5.5 V (6.0 V)
- Output Voltage Range: 1.2 V to 4.8 V (0.1 V step)
- Output Voltage Accuracy: $\pm 0.8\%$ ($V_{\text{SET}} \geq 1.8 \text{ V}$, $T_a = 25^\circ\text{C}$)
- Supply Current: Typ. 9.5 μA
- Output Noise: Typ. 8 μV_{rms} ($I_{\text{OUT}} = 250 \text{ mA}$)
- Ripple Rejection: Typ. 90 dB ($f = 1\text{kHz}$)
Typ. 85 dB ($f = 10\text{kHz}$)
Typ. 65 dB ($f = 100\text{kHz}$)
- Dropout Voltage: Typ. 0.090 V ($I_{\text{OUT}} = 250 \text{ mA}$, $V_{\text{SET}} = 2.8 \text{ V}$, RP123Z)
Typ. 0.105 V ($I_{\text{OUT}} = 250 \text{ mA}$, $V_{\text{SET}} = 2.8 \text{ V}$, RP123K)
- Protection Features: Thermal Shutdown Protection (Detection Temp. Typ. 165 $^\circ\text{C}$)
Inrush Current Limit at Typ. 150 mA for appr. 700 μs period after startup
- Ceramic Capacitor (C_{IN} , C_{OUT}): 1.0 μF or more (No Need of Noise Bypass Capacitor)

TYPICAL APPLICATIONS

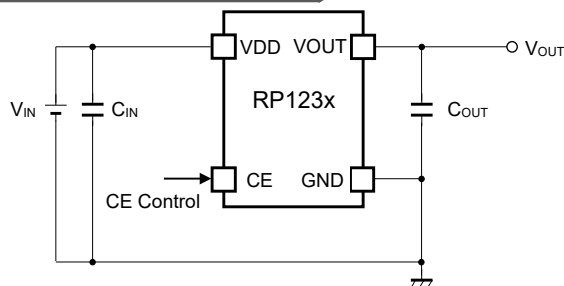

Without a bypass capacitor for noise

APPLICATIONS

- Mobile Phones and Tablets, Digital Cameras, Audio Devices, and Battery-powered Equipment
- RF Modules
- Clock Generator: VCO, PLL, etc.
- Noise-sensitive Devices: ADC, DAC

PACKAGE



WLCSP-4-P8
0.64 x 0.64 x 0.36 (mm)

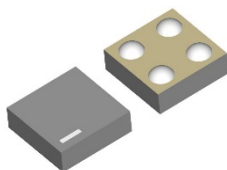

WLCSP-4-P12
0.64 x 0.64 x 0.26 (mm)

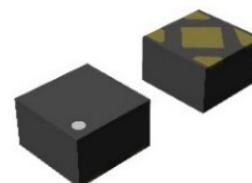

DFN(PLP)1010-4
1.0 x 1.0 x 0.6 (mm)

SELECTION GUIDE

The set output voltage and the auto-discharge function⁽¹⁾ are user-selectable.

Product Name	Package	Quantity per Reel	Pb Free	Halogen Free
RP123Zxx1*-TR-F	WLCSP-4-P8	5,000 pcs	Yes	Yes
RP123Zxx3*-TR-F	WLCSP-4-P12	10,000 pcs	Yes	Yes
RP123Kxx1*-TR	DFN(PLP)1010-4	10,000 pcs	Yes	Yes

xx: Specify the set output voltage (V_{SET}) within the range of 1.2 V to 4.8 V in 0.1 V steps.

The voltage in 0.05 V step is shown as follows.

Ex. 1.85 V: RP123x18x*5

* : Specify whether with the auto-discharge or not.

B: without the auto-discharge function

D: with the auto-discharge function

BLOCK DIAGRAMS

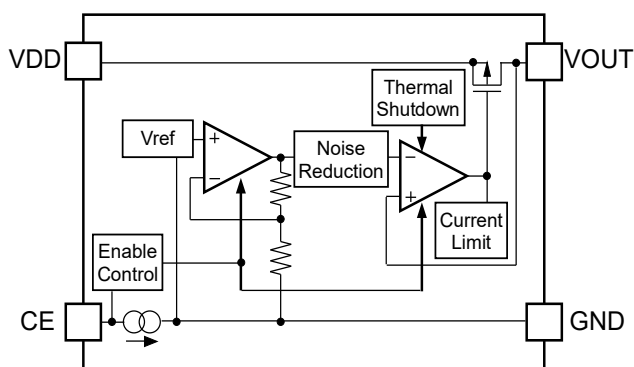

RP123xxxxB Block Diagram

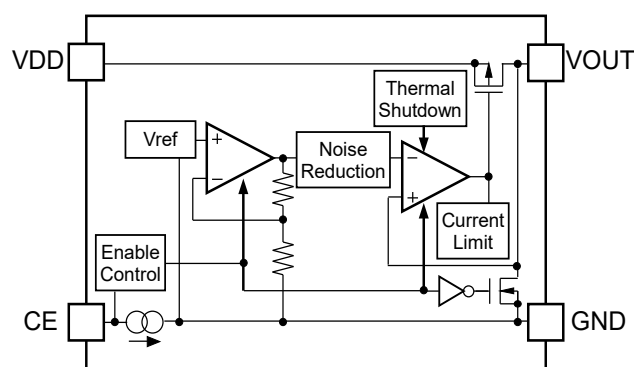

RP123xxxxD Block Diagram

⁽¹⁾ Auto-discharge function quickly lowers the output voltage to 0 V, when the chip enable signal is switched from the active mode to the standby mode, by releasing the electrical charge accumulated in the external capacitor.

PIN DESCRIPTIONS

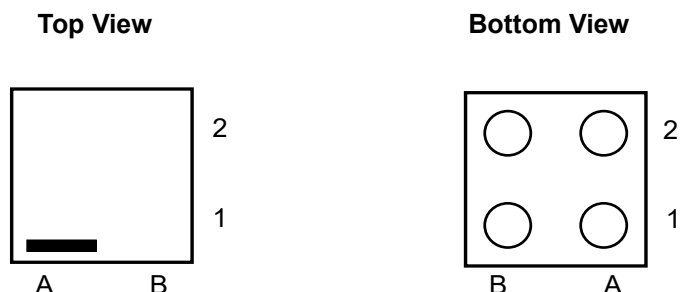

RP123Z (WLCSP-4-P8 / WLCSP-4-P12) Pin Configuration

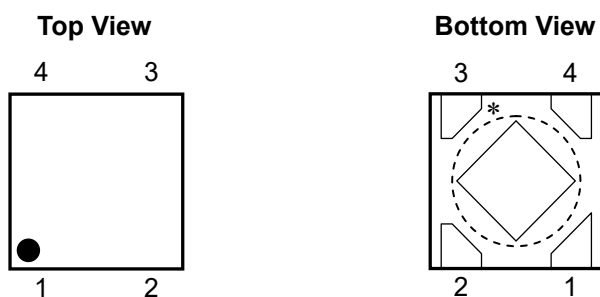

RP123K (DFN(PLP)1010-4) Pin Configuration

RP123Zxx1x(WLCSP-4-P8), RP123Zxx3x(WLCSP-4-P12) Pin Description

Pin No.	Symbol	Description
A1	VDD	Input Pin
A2	VOUT	Output Pin
B1	CE	Chip Enable Pin, Active-high
B2	GND	Ground Pin

RP123K Pin Description

Pin. No.	Symbol	Description
1	VOUT	Output Pin
2	GND	Ground Pin
3	CE	Chip Enable Pin, Active-high
4	VDD	Input Pin

* The tab on the bottom of the package is a substrate potential (GND). It is recommended that this tab be connected to the ground plane on the board but it is possible to leave the tab floating.

ABSOLUTE MAXIMUM RATINGS

Symbol	Item	Rating	Unit
V _{IN}	Input Voltage	-0.3 to 6.0	V
V _{CE}	Input Voltage (CE pin)	-0.3 to 6.0	V
V _{OUT}	Output Voltage	-0.3 to V _{IN} + 0.3	V
I _{OUT}	Output Current	600	mA
P _D	Power Dissipation	Refer to Appendix "POWER DISSIPATION"	
T _j	Junction Temperature Range	-40 to 125	°C
T _{stg}	Storage Temperature Range	-55 to 125	°C

ABSOLUTE MAXIMUM RATINGS

Electronic and mechanical stress momentarily exceeded absolute maximum ratings may cause permanent damage and may degrade the life time and safety for both device and system using the device in the field. The functional operation at or over these absolute maximum ratings are not assured.

RECOMMENDED OPERATING CONDITIONS

Symbol	Item	Rating	Unit
V _{IN}	Input Voltage	1.9 to 5.5	V
T _a	Operating Temperature Range	-40 to 85	°C

RECOMMENDED OPERATING CONDITIONS

All of electronic equipment should be designed that the mounted semiconductor devices operate within the recommended operating conditions. The semiconductor devices cannot operate normally over the recommended operating conditions, even if they are used over such ratings by momentary electronic noise or surge. And the semiconductor devices may receive serious damage when they continue to operate over the recommended operating conditions.

ELECTRICAL CHARACTERISTICS

$V_{IN} = V_{SET} + 1\text{ V}$ ($V_{IN} = 5.5\text{ V}$ when $V_{SET} \geq 4.5\text{ V}$), $I_{OUT} = 1\text{ mA}$, $C_{IN} = C_{OUT} = 1\mu\text{F}$, unless otherwise specified.

The specifications surrounded by are guaranteed by design engineering at $-40^{\circ}\text{C} \leq T_a \leq 85^{\circ}\text{C}$.

RP123xxxx Electrical Characteristics

($T_a = 25^{\circ}\text{C}$)

Symbol	Parameter		Conditions	Min.	Typ.	Max.	Unit
V_{OUT}	Output Voltage		$T_a = 25^{\circ}\text{C}$	$V_{SET} \geq 1.8\text{V}$	x0.992	x1.008	V
			$V_{SET} < 1.8\text{V}$	-14		+14	mV
		$-40^{\circ}\text{C} \leq T_a \leq 85^{\circ}\text{C}$	$V_{SET} \geq 1.8\text{V}$	x0.987		x1.012	V
			$V_{SET} < 1.8\text{V}$	Refer to <i>PRODUCT-SPECIFIC ELECTRICAL CHARACTERISTICS</i>			
I_{OUT}	Output Current			250			mA
$\frac{\Delta V_{OUT}}{\Delta I_{OUT}}$	Load Regulation	RP123Z	$1\text{ mA} \leq I_{OUT} \leq 250\text{ mA}$ $V_{IN} = V_{SET} + 0.5\text{ V}$, $V_{IN} \geq 1.9\text{ V}$		2	15	mV
		RP123K	$1\text{ mA} \leq I_{OUT} \leq 250\text{ mA}$		8	25	
V_{DIF}	Dropout Voltage		$I_{OUT} = 250\text{ mA}$	Refer to <i>Dropout Voltage Characteristics</i>			
I_{SS}	Supply Current		$I_{OUT} = 0\text{ mA}$		9.5	25	μA
$I_{STANDBY}$	Standby Current		$V_{IN} = V_{SET} = 5.5\text{ V}$, $V_{CE} = 0\text{ V}$		0.01	0.3	μA
$\frac{\Delta V_{OUT}}{\Delta V_{IN}}$	Line Regulation	$1.2\text{V} \leq V_{SET} < 1.4\text{V}$	$1.9\text{V} \leq V_{IN} \leq 5.5\text{V}$		0.02	0.10	%V
		$1.4\text{V} \leq V_{SET} < 4.3\text{V}$	$V_{SET} + 0.5\text{V} \leq V_{IN} \leq 5.5\text{V}$				
		$4.3\text{V} \leq V_{SET} \leq 4.8\text{V}$	$V_{SET} + 0.3\text{V} \leq V_{IN} \leq 5.5\text{V}$				
RR	Ripple Rejection	Ripple 0.2 Vp-p, $I_{OUT} = 20\text{ mA}$	$f = 1\text{ kHz}$		90		dB
			$f = 10\text{ kHz}$		85		
			$f = 100\text{ kHz}$		65		
I_{SC}	Short Current Limit		$V_{OUT} = 0\text{ V}$		45		mA
I_{PD}	CE Pull-down Current				0.25	0.50	μA
V_{CEH}	CE Input Voltage, high			1.0			V
V_{CEL}	CE Input Voltage, low					0.4	V
en	Output Noise	BW =10Hz to 100kHz	$I_{OUT} = 1\text{ mA}$		12		μVrms
			$I_{OUT} = 250\text{ mA}$		8		
T_{TSD}	Thermal Shutdown Temperature, detection		Junction Temperature		165		$^{\circ}\text{C}$
T_{TSR}	Thermal Shutdown Temperature, released		Junction Temperature		110		$^{\circ}\text{C}$
R_{LOW}	Auto-discharge NMOS On-resistance (RP123xxxxD only)		$V_{IN} = 5.0\text{ V}$, $CE = 0\text{ V}$,		50		Ω

All test items listed under Electrical Characteristics are done under the pulse load condition ($T_j \approx T_a = 25^{\circ}\text{C}$) except Ripple Rejection and Output Noise.

ELECTRICAL CHARACTERISTICS

The specifications surrounded by are guaranteed by design engineering at $-40^{\circ}\text{C} \leq T_a \leq 85^{\circ}\text{C}$.

Dropout Voltage Characteristics

($T_a = 25^{\circ}\text{C}$)

Symbol	Parameter		Conditions	Typ.	Max.	Unit	
V_{DIF}	Dropout Voltage	RP123Z	$I_{\text{OUT}}=250\text{mA}$	$1.2 \leq V_{\text{SET}} < 1.6\text{V}$	(1)	(1)	V
				$1.6 \leq V_{\text{SET}} < 1.7\text{V}$	(1)	0.230 ⁽²⁾	
				$1.7 \leq V_{\text{SET}} < 1.8\text{V}$	0.140 ⁽²⁾	0.220	
				$1.8 \leq V_{\text{SET}} < 1.9\text{V}$	0.135	0.205	
				$1.9 \leq V_{\text{SET}} < 2.0\text{V}$	0.125	0.190	
				$2.0 \leq V_{\text{SET}} < 2.1\text{V}$	0.120	0.180	
				$2.1 \leq V_{\text{SET}} < 2.2\text{V}$	0.115	0.170	
				$2.2 \leq V_{\text{SET}} < 2.5\text{V}$	0.110	0.165	
				$2.5 \leq V_{\text{SET}} < 2.8\text{V}$	0.100	0.150	
				$2.8 \leq V_{\text{SET}} < 3.3\text{V}$	0.090	0.140	
				$3.3 \leq V_{\text{SET}} < 3.6\text{V}$	0.080	0.130	
				$3.6 \leq V_{\text{SET}} < 4.0\text{V}$	0.075	0.125	
		$4.0 \leq V_{\text{SET}} \leq 4.8\text{V}$	0.070	0.120			
		RP123K	$I_{\text{OUT}}=250\text{mA}$	$1.2 \leq V_{\text{SET}} < 1.6\text{V}$	(1)	(1)	V
				$1.6 \leq V_{\text{SET}} < 1.7\text{V}$	(1)	0.260 ⁽²⁾	
				$1.7 \leq V_{\text{SET}} < 1.8\text{V}$	0.160 ⁽²⁾	0.245	
				$1.8 \leq V_{\text{SET}} < 1.9\text{V}$	0.150	0.230	
				$1.9 \leq V_{\text{SET}} < 2.0\text{V}$	0.140	0.215	
				$2.0 \leq V_{\text{SET}} < 2.1\text{V}$	0.135	0.205	
				$2.1 \leq V_{\text{SET}} < 2.2\text{V}$	0.130	0.195	
				$2.2 \leq V_{\text{SET}} < 2.5\text{V}$	0.125	0.190	
				$2.5 \leq V_{\text{SET}} < 2.8\text{V}$	0.115	0.175	
				$2.8 \leq V_{\text{SET}} < 3.3\text{V}$	0.105	0.165	
				$3.3 \leq V_{\text{SET}} < 3.6\text{V}$	0.095	0.155	
$3.6 \leq V_{\text{SET}} < 4.0\text{V}$	0.090			0.150			
$4.0 \leq V_{\text{SET}} \leq 4.8\text{V}$	0.085	0.145					

⁽¹⁾ Input voltage must be equal or more than the minimum operating voltage of 1.9 V, and Dropout Voltage is calculated in the equation of 1.9 V – Output Voltage.

⁽²⁾ When "Output voltage + Dropout Voltage" < 1.9 V, input voltage must be equal or more than the minimum operating voltage of 1.9 V.

The specifications surrounded by are guaranteed by design engineering at $-40^{\circ}\text{C} \leq T_a \leq 85^{\circ}\text{C}$

RP123Z Product-specific Electrical Characteristics

Product Name	V _{OUT} [V]						V _{DIF} [V]	
	T _a = 25°C			-40°C ≤ T _a ≤ 85°C			Typ.	Max.
	Min.	Typ.	Max.	Min.	Typ.	Max.		
RP123Z12xx	1.186	1.200	1.214	1.180	1.200	1.218	(1)	(1)
RP123Z12xx5	1.236	1.250	1.264	1.230	1.250	1.268	(1)	(1)
RP123Z13xx	1.286	1.300	1.314	1.280	1.300	1.319	(1)	(1)
RP123Z14x	1.386	1.400	1.414	1.379	1.400	1.419	(1)	(1)
RP123Z15xx	1.486	1.500	1.514	1.479	1.500	1.519	(1)	(1)
RP123Z16xx	1.586	1.600	1.614	1.578	1.600	1.620	(1)	0.230 ⁽²⁾
RP123Z17xx	1.686	1.700	1.714	1.678	1.700	1.720	0.140 ⁽²⁾	0.220
RP123Z18xx	1.786	1.800	1.814	1.777	1.800	1.821	0.135	0.205
RP123Z18xx5	1.836	1.850	1.864	1.826	1.850	1.872	0.135	0.205
RP123Z19xx	1.885	1.900	1.915	1.876	1.900	1.922	0.125	0.190
RP123Z20xx	1.984	2.000	2.016	1.974	2.000	2.024	0.120	0.180
RP123Z21xx	2.084	2.100	2.116	2.073	2.100	2.125	0.115	0.170
RP123Z22xx	2.183	2.200	2.217	2.172	2.200	2.226	0.110	0.165
RP123Z23xx	2.282	2.300	2.318	2.271	2.300	2.327	0.110	0.165
RP123Z24xx	2.381	2.400	2.419	2.369	2.400	2.428	0.110	0.165
RP123Z25xx	2.480	2.500	2.520	2.468	2.500	2.530	0.100	0.150
RP123Z26xx	2.580	2.600	2.620	2.567	2.600	2.631	0.100	0.150
RP123Z27xx	2.679	2.700	2.721	2.665	2.700	2.732	0.100	0.150
RP123Z27xx5	2.728	2.750	2.772	2.715	2.750	2.783	0.100	0.150
RP123Z28xx	2.778	2.800	2.822	2.764	2.800	2.833	0.090	0.140
RP123Z28xx5	2.828	2.850	2.872	2.813	2.850	2.884	0.090	0.140
RP123Z29xx	2.877	2.900	2.923	2.863	2.900	2.934	0.090	0.140
RP123Z29xx5	2.927	2.950	2.973	2.912	2.950	2.985	0.090	0.140
RP123Z30xx	2.976	3.000	3.024	2.961	3.000	3.036	0.090	0.140
RP123Z31xx	3.076	3.100	3.124	3.060	3.100	3.137	0.090	0.140
RP123Z31xx5	3.125	3.150	3.175	3.110	3.150	3.187	0.090	0.140
RP123Z32xx	3.175	3.200	3.225	3.159	3.200	3.238	0.090	0.140
RP123Z33xx	3.274	3.300	3.326	3.258	3.300	3.339	0.080	0.130
RP123Z34xx	3.373	3.400	3.427	3.356	3.400	3.440	0.080	0.130
RP123Z35xx	3.472	3.500	3.528	3.455	3.500	3.542	0.080	0.130
RP123Z36xx	3.572	3.600	3.628	3.554	3.600	3.643	0.075	0.125
RP123Z37xx	3.671	3.700	3.729	3.652	3.700	3.744	0.075	0.125
RP123Z38xx	3.770	3.800	3.830	3.751	3.800	3.845	0.075	0.125
RP123Z39xx	3.869	3.900	3.931	3.850	3.900	3.946	0.075	0.125
RP123Z40xx	3.968	4.000	4.032	3.948	4.000	4.048	0.070	0.120
RP123Z41xx	4.068	4.100	4.132	4.047	4.100	4.149	0.070	0.120
RP123Z42xx	4.167	4.200	4.233	4.146	4.200	4.250	0.070	0.120
RP123Z43xx	4.266	4.300	4.334	4.245	4.300	4.351	0.070	0.120
RP123Z44xx	4.365	4.400	4.435	4.343	4.400	4.452	0.070	0.120
RP123Z45xx	4.464	4.500	4.536	4.442	4.500	4.554	0.070	0.120
RP123Z45xx5	4.514	4.550	4.586	4.491	4.550	4.604	0.070	0.120
RP123Z46xx	4.564	4.600	4.636	4.541	4.600	4.655	0.070	0.120
RP123Z47xx	4.663	4.700	4.737	4.639	4.700	4.756	0.070	0.120
RP123Z48xx	4.762	4.800	4.838	4.738	4.800	4.857	0.070	0.120

⁽¹⁾Input voltage must be equal or more than the minimum operating voltage of 1.9 V, and Dropout Voltage is calculated in the equation of 1.9 V – Output Voltage.

⁽²⁾When "Output voltage + Dropout Voltage" < 1.9 V, input voltage must be equal or more than the minimum operating voltage of 1.9 V.

The specifications surrounded by are guaranteed by design engineering at $-40^{\circ}\text{C} \leq T_a \leq 85^{\circ}\text{C}$

RP123Kxx1x Product-specific Electrical Characteristics

Product Name	$V_{\text{OUT}} [\text{V}]$						$V_{\text{DIF}} [\text{V}]$	
	$T_a = 25^{\circ}\text{C}$			$-40^{\circ}\text{C} \leq T_a \leq 85^{\circ}\text{C}$			Typ.	Max.
	Min.	Typ.	Max.	Min.	Typ.	Max.		
RP123K121x	1.186	1.200	1.214	1.180	1.200	1.218	(1)	(1)
RP123K121x5	1.236	1.250	1.264	1.230	1.250	1.268	(1)	(1)
RP123K131x	1.286	1.300	1.314	1.280	1.300	1.319	(1)	(1)
RP123K141x	1.386	1.400	1.414	1.379	1.400	1.419	(1)	(1)
RP123K151x	1.486	1.500	1.514	1.479	1.500	1.519	(1)	(1)
RP123K161x	1.586	1.600	1.614	1.578	1.600	1.620	(1)	0.260 ⁽²⁾
RP123K171x	1.686	1.700	1.714	1.678	1.700	1.720	0.160 ⁽²⁾	0.245
RP123K181x	1.786	1.800	1.814	1.777	1.800	1.821	0.150	0.230
RP123K181x5	1.836	1.850	1.864	1.826	1.850	1.872	0.150	0.230
RP123K191x	1.885	1.900	1.915	1.876	1.900	1.922	0.140	0.215
RP123K201x	1.984	2.000	2.016	1.974	2.000	2.024	0.135	0.205
RP123K211x	2.084	2.100	2.116	2.073	2.100	2.125	0.130	0.195
RP123K221x	2.183	2.200	2.217	2.172	2.200	2.226	0.125	0.190
RP123K231x	2.282	2.300	2.318	2.271	2.300	2.327	0.125	0.190
RP123K241x	2.381	2.400	2.419	2.369	2.400	2.428	0.125	0.190
RP123K251x	2.480	2.500	2.520	2.468	2.500	2.530	0.115	0.175
RP123K261x	2.580	2.600	2.620	2.567	2.600	2.631	0.115	0.175
RP123K271x	2.679	2.700	2.721	2.665	2.700	2.732	0.115	0.175
RP123K271x5	2.728	2.750	2.772	2.715	2.750	2.783	0.115	0.175
RP123K281x	2.778	2.800	2.822	2.764	2.800	2.833	0.105	0.165
RP123K281x5	2.828	2.850	2.872	2.813	2.850	2.884	0.105	0.165
RP123K291x	2.877	2.900	2.923	2.863	2.900	2.934	0.105	0.165
RP123K291x5	2.927	2.950	2.973	2.912	2.950	2.985	0.105	0.165
RP123K301x	2.976	3.000	3.024	2.961	3.000	3.036	0.105	0.165
RP123K311x	3.076	3.100	3.124	3.060	3.100	3.137	0.105	0.165
RP123K311x5	3.125	3.150	3.175	3.110	3.150	3.187	0.105	0.165
RP123K321x	3.175	3.200	3.225	3.159	3.200	3.238	0.105	0.165
RP123K331x	3.274	3.300	3.326	3.258	3.300	3.339	0.095	0.155
RP123K341x	3.373	3.400	3.427	3.356	3.400	3.440	0.095	0.155
RP123K351x	3.472	3.500	3.528	3.455	3.500	3.542	0.095	0.155
RP123K361x	3.572	3.600	3.628	3.554	3.600	3.643	0.090	0.150
RP123K371x	3.671	3.700	3.729	3.652	3.700	3.744	0.090	0.150
RP123K381x	3.770	3.800	3.830	3.751	3.800	3.845	0.090	0.150
RP123K391x	3.869	3.900	3.931	3.850	3.900	3.946	0.090	0.150
RP123K401x	3.968	4.000	4.032	3.948	4.000	4.048	0.085	0.145
RP123K411x	4.068	4.100	4.132	4.047	4.100	4.149	0.085	0.145
RP123K421x	4.167	4.200	4.233	4.146	4.200	4.250	0.085	0.145
RP123K431x	4.266	4.300	4.334	4.245	4.300	4.351	0.085	0.145
RP123K441x	4.365	4.400	4.435	4.343	4.400	4.452	0.085	0.145
RP123K451x	4.464	4.500	4.536	4.442	4.500	4.554	0.085	0.145
RP123K451x5	4.514	4.550	4.586	4.491	4.550	4.604	0.085	0.145
RP123K461x	4.564	4.600	4.636	4.541	4.600	4.655	0.085	0.145
RP123K471x	4.663	4.700	4.737	4.639	4.700	4.756	0.085	0.145
RP123K481x	4.762	4.800	4.838	4.738	4.800	4.857	0.085	0.145

⁽¹⁾Input voltage must be equal or more than the minimum operating voltage of 1.9 V, and Dropout Voltage is calculated in the equation of $1.9 \text{ V} - \text{Output Voltage}$.

⁽²⁾When "Output voltage + Dropout Voltage" < 1.9 V, input voltage must be equal or more than the minimum operating voltage of 1.9 V.

TYPICAL APPLICATION CIRCUIT

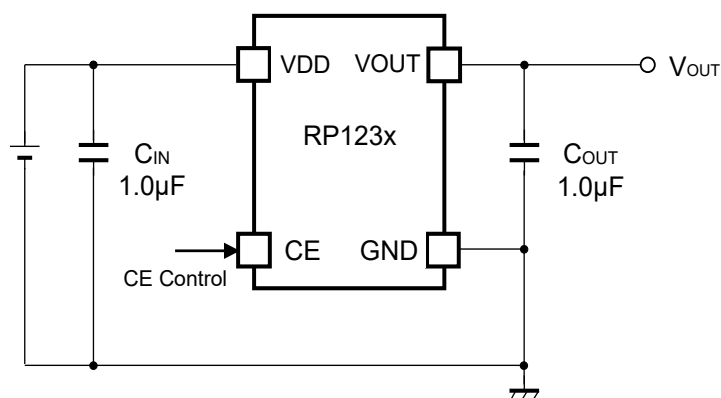

RP123x Typical Application Circuit

Technical Notes Related to External Components

- Ensure the VDD and GND lines are sufficiently robust. If their impedances are too high, noise pickup or unstable operation may result. Connect a 1.0 µF or more input capacitor (C_{IN}) between the VDD and GND pins with shortest-distance wiring. It is recommended to use a ceramic capacitor of 6.3 V and more such as the X7R and the X5R having small temperature dependence to ESR, ESL, and capacitance.
- Phase compensation is provided to secure stable operation even when the load current is varied. For this purpose, use a ceramic capacitor of 1.0 µF or more with ESR (Equivalent Series Resistance) of up to 300 mΩ to connect the output capacitor (C_{OUT}) between the VOUT and GND pins with shortest-distance wiring. Besides, set for the output capacitor to ensure the following effective capacitance in consideration of the dependence of temperature, DC bias, and package size.

Set Output Voltage (V_{SET})	Effective Capacitance
$1.2\text{ V} \leq V_{SET} < 2.0\text{ V}$	0.75 µF and more
$2.0\text{ V} \leq V_{SET} < 3.4\text{ V}$	0.70 µF and more
$3.4\text{ V} \leq V_{SET} \leq 4.8\text{ V}$	0.60 µF and more

In case of using a tantalum type capacitor with a large ESR, the output might become unstable. Evaluate your circuit including consideration of frequency characteristics with a parallel connection the above ceramic and the tantalum type capacitors.

THEORY OF OPERATION

Inrush Current Limit

The inrush current limit value at start-up increases in proportion to the capacitance of C_{OUT} . If not flow the load current (I_{LOAD}) except the charge current to C_{OUT} , the inrush current reaches 150 mA when the effective capacitance of C_{OUT} becomes approx. 3.6 μ F or more, and the inrush current limit protection runs. During appr.700 μ s after the CE pin becomes "H", the inrush current, which occurs at charging the capacitor of C_{OUT} , is limited at approx.150 mA. The power-on time (t_{ON}) can be calculated from the following equation. If the capacitance value of C_{OUT} is too much, the time-out occurs and the inrush current increases.

$$t_{ON} = t_D + C_{OUT} \cdot V_{SET} / I_{LIM_START}$$

t_D : Delay Time at Start-up Typ.50 μ s

V_{SET} : Set Output Voltage

I_{LIM_START} : Limit Current at Start-up Typ.150 mA

If flow the load current (I_{LOAD}) except the charge current to C_{OUT} during start-up, the start-up time becomes longer. The load current over I_{LIM_START} cannot be applied.

Minimum Operating Voltage

The RP123x does not include an UVLO circuit. To make the internal circuit operate normally and to ensure good output regulation, V_{IN} has to be: $V_{IN} \geq V_{SET} + V_{DIF}$ (Min.1.9 V). To bring out the best characteristics of the output noise voltage, the ripple rejection and the load transient response, V_{IN} has to be $V_{IN} = V_{SET} + 1.0$ V.

Thermal Shutdown Protection

Thermal shutdown deactivates the circuit when the junction temperature exceeds the thermal shutdown threshold (T_{TSD}) of Typ. 165°C, and reactivates it when the junction temperature falls below the thermal shutdown release threshold (T_{TSR}) of Typ. 110°C. During the reactivation, the inrush current limit is in operation. Note that deactivation and activation cycle can be repeated due to load, heat dissipation and ambient temperature conditions. Thermal shutdown cannot be used for the purpose of heat sink, so the repetitive cycles of deactivation and activation may affect the reliability of the device.

TYPICAL CHARACTERISTICS

Note: Typical Characteristics are intended to be used as reference data; they are not guaranteed.

1) Output Voltage vs Temperature (C_{IN} = Ceramic 1.0 μ F, C_{OUT} = Ceramic 1.0 μ F)

RP123x12xx, V_{IN} = 2.2 V, I_{OUT} = 1 mA

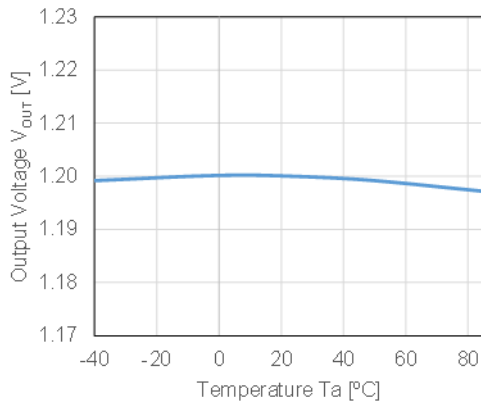

RP123x28xx, V_{IN} = 3.8 V, I_{OUT} = 1 mA

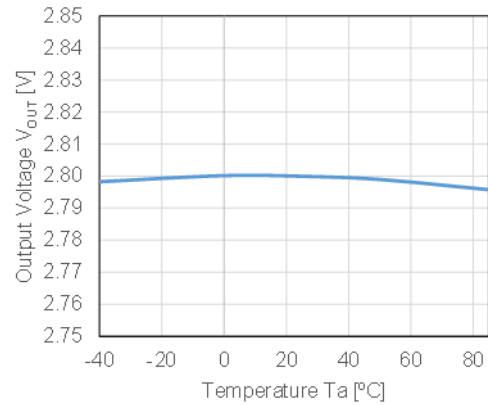

RP123x48xx, V_{IN} = 5.5 V, I_{OUT} = 1 mA

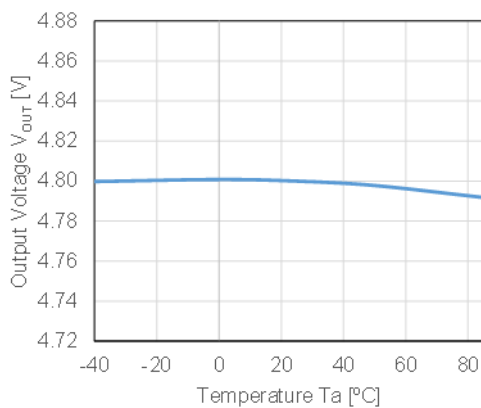

2) Supply Current vs Temperature (C_{IN} = Ceramic 1.0 μ F, C_{OUT} = Ceramic 1.0 μ F)

RP123x12xx, V_{IN} = 2.2 V

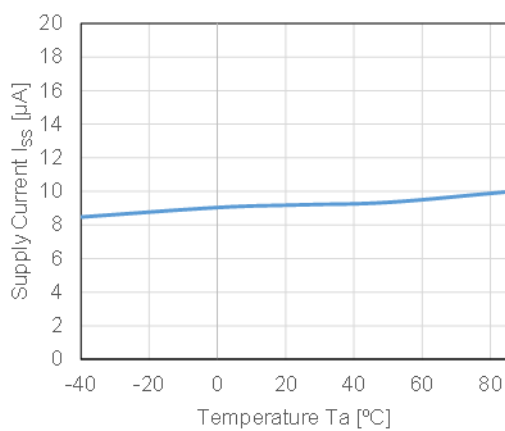

RP123x28xx, V_{IN} = 3.8 V

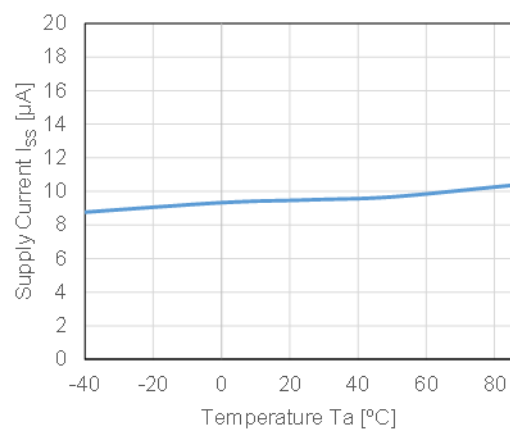

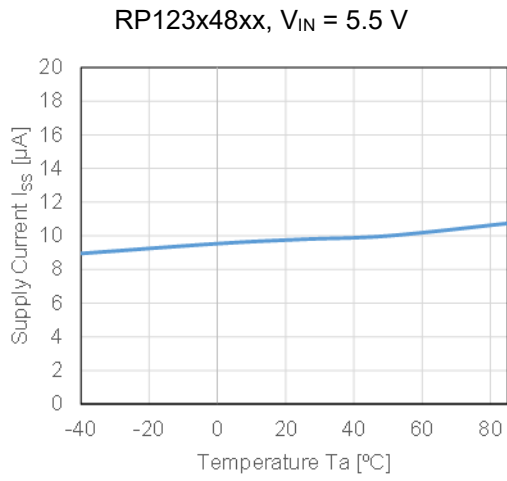

3) Dropout Voltage vs Output Current ($C_{IN} = \text{Ceramic } 1.0\ \mu\text{F}$, $C_{OUT} = \text{Ceramic } 1.0\ \mu\text{F}$)

RP123Z18xx

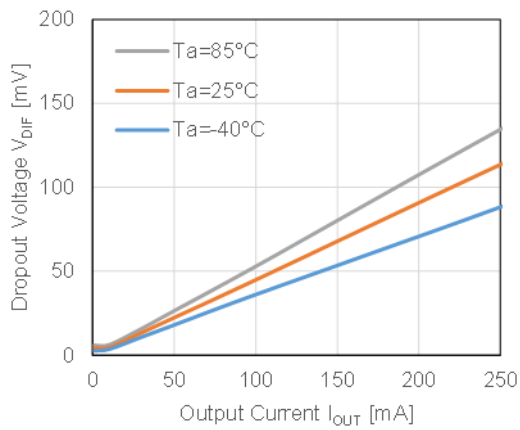

RP123K181x

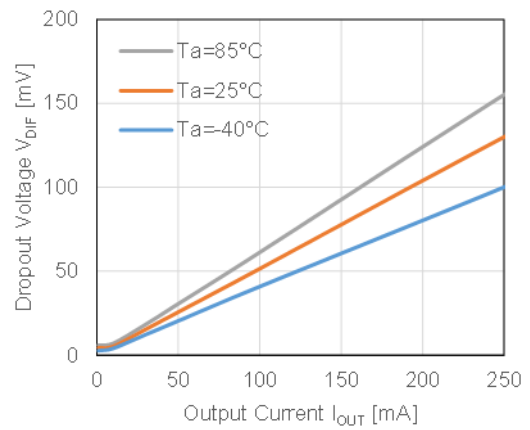

RP123Z28xx

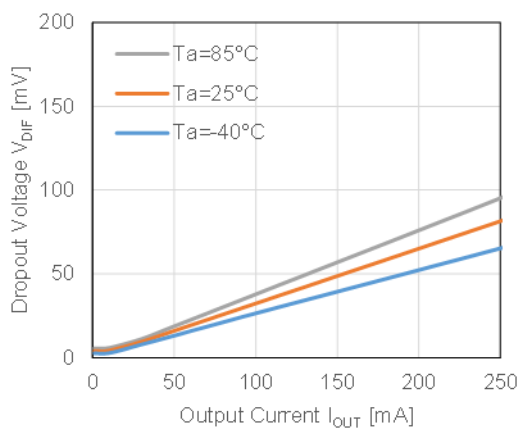

RP123K281x

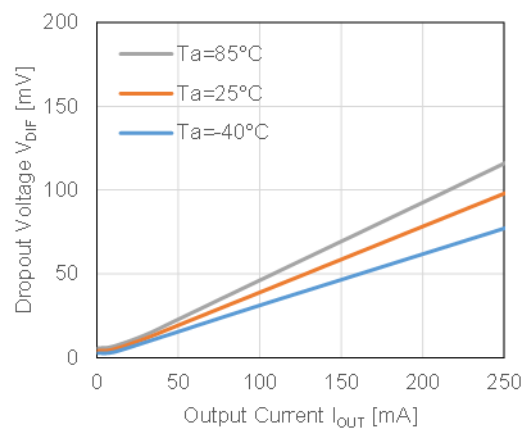

RP123Z48xx

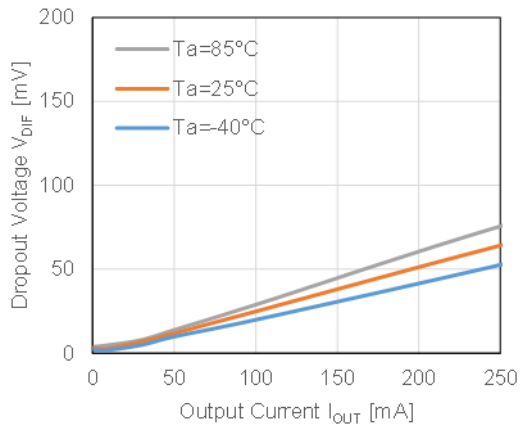

RP123K481x

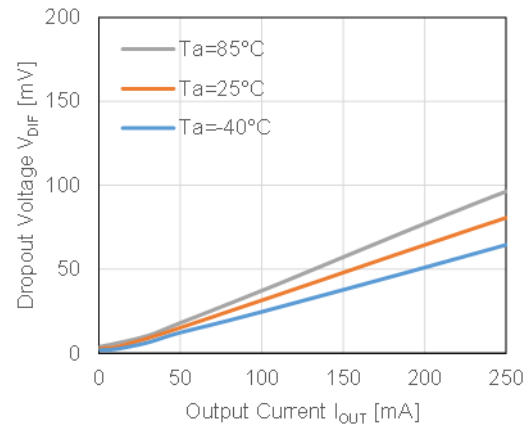

4) Dropout Voltage vs Temperature ($C_{IN} = \text{Ceramic } 1.0 \mu\text{F}$, $C_{OUT} = \text{Ceramic } 1.0 \mu\text{F}$)

RP123Z18xx

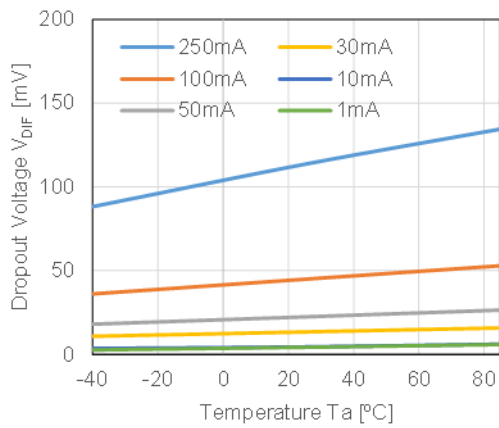

RP123K181x

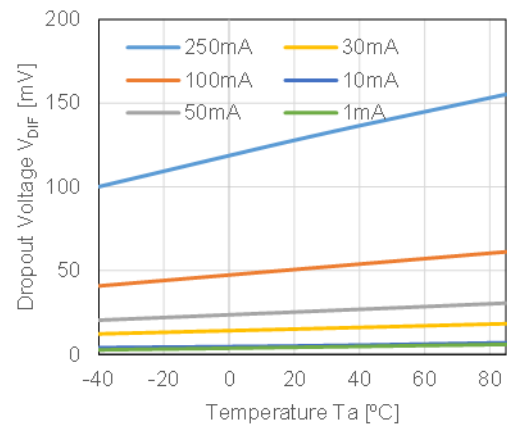

RP123Z28xx

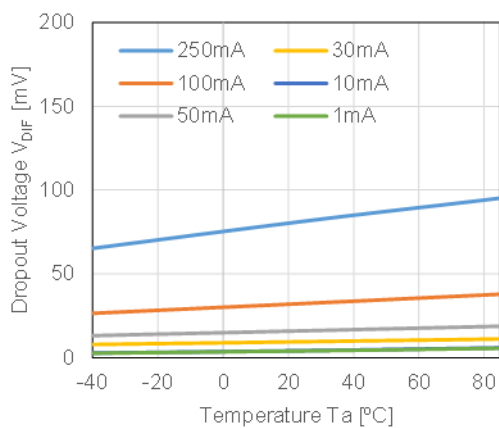

RP123K281x

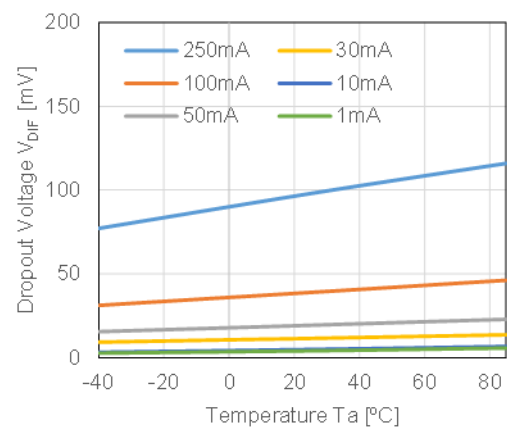

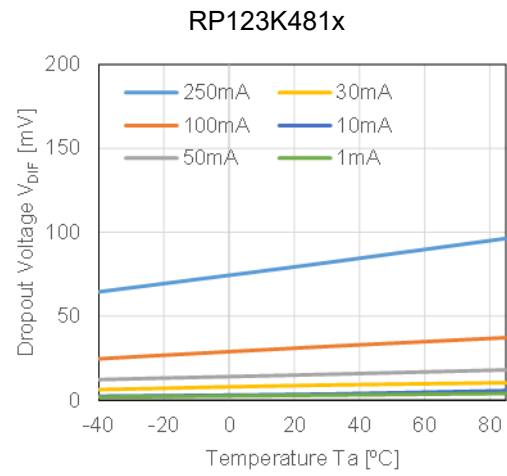
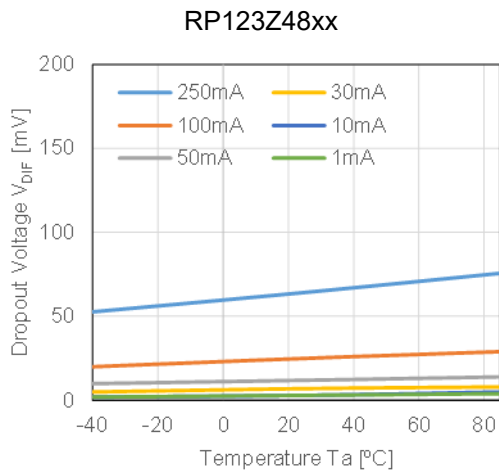

5) Dropout Voltage vs Set Output Voltage ($C_{IN} = \text{Ceramic } 1.0 \mu\text{F}$, $C_{OUT} = \text{Ceramic } 1.0 \mu\text{F}$, $T_a = 25^\circ\text{C}$)

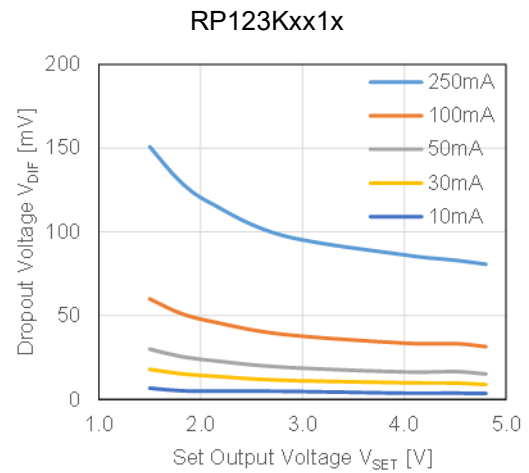
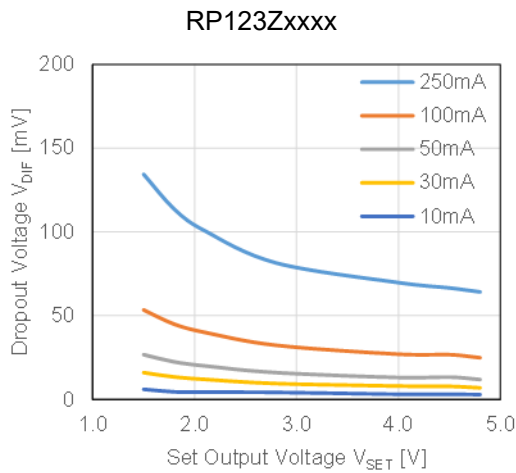

6) Output Voltage vs Output Current ($C_{IN} = \text{Ceramic } 1.0 \mu\text{F}$, $C_{OUT} = \text{Ceramic } 1.0 \mu\text{F}$, $T_a = 25^\circ\text{C}$)

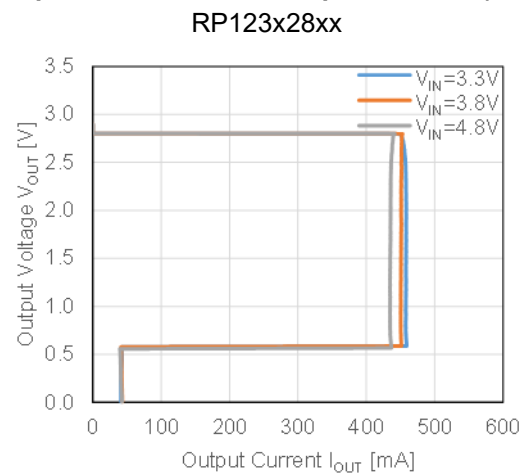
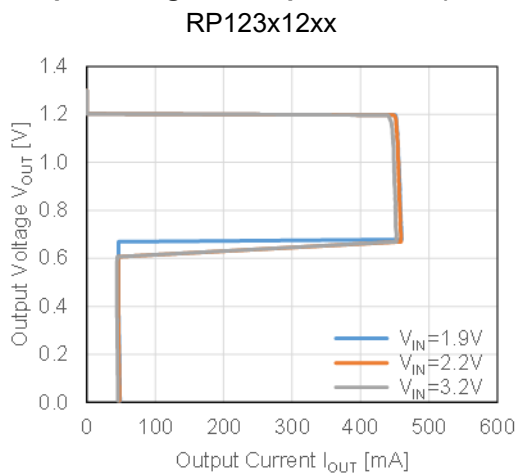

RP123x48xx

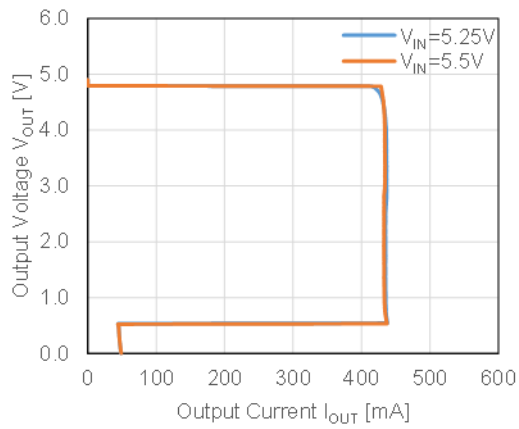

7) Output Voltage vs Input Voltage (C_{IN} = Ceramic 1.0 μ F, C_{OUT} = Ceramic 1.0 μ F, T_a = 25°C)

RP123x12xx

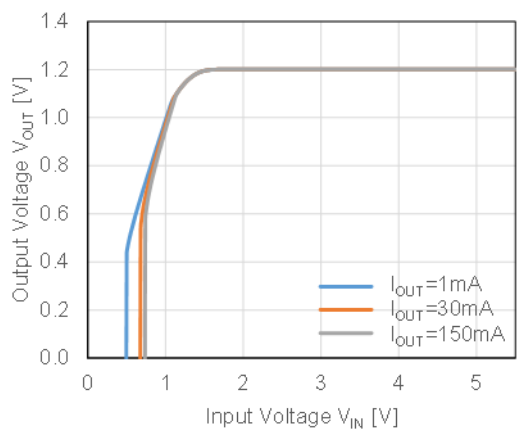

RP123x28xx

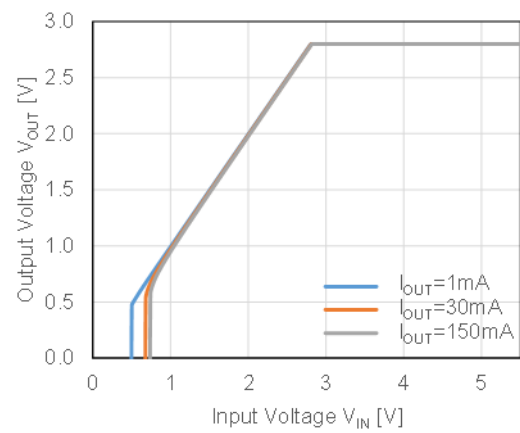

RP123x48xx

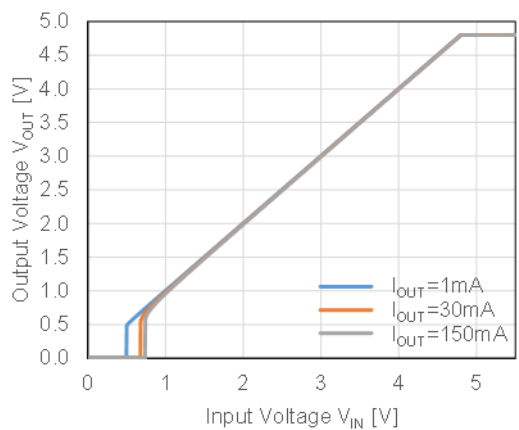

8) Supply Current vs Input Voltage ($C_{IN} = \text{Ceramic } 1.0 \mu\text{F}$, $C_{OUT} = \text{Ceramic } 1.0 \mu\text{F}$, $T_a = 25^\circ\text{C}$)

RP123x12xx

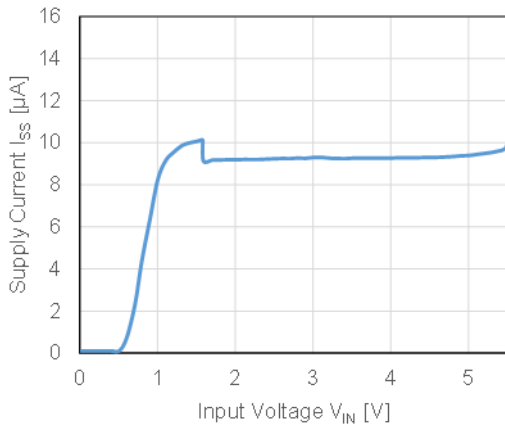

RP123x28xx

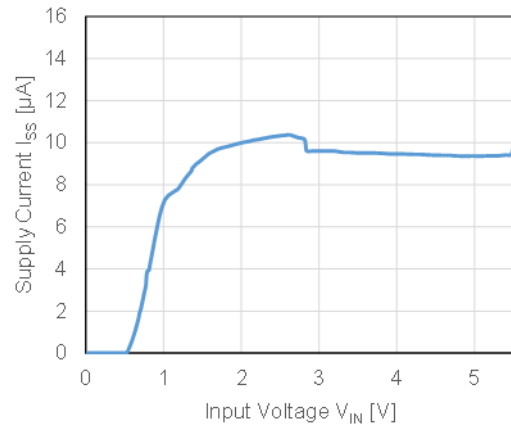

RP123x48xx

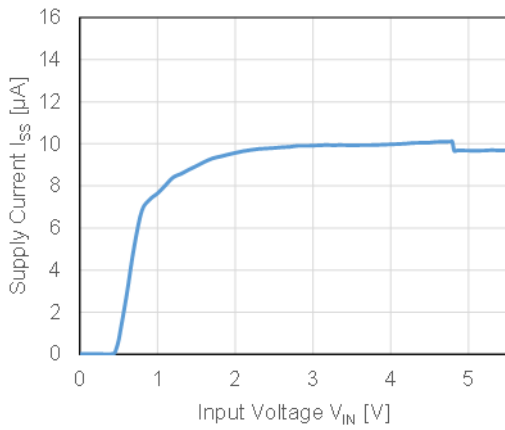

9) Supply Current vs Output Current ($C_{IN} = \text{Ceramic } 1.0 \mu\text{F}$, $C_{OUT} = \text{Ceramic } 1.0 \mu\text{F}$, $T_a = 25^\circ\text{C}$)

RP123x12xx, $V_{IN} = 2.2 \text{ V}$

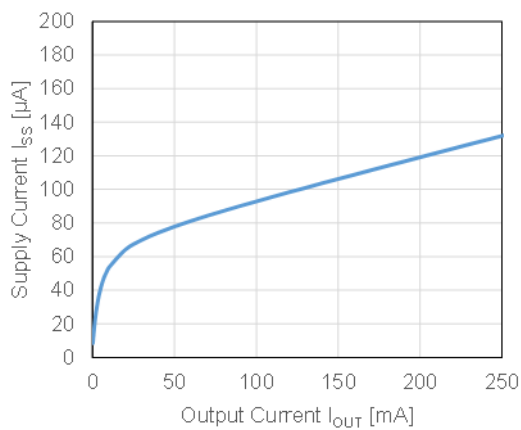

RP123x28xx, $V_{IN} = 3.8 \text{ V}$

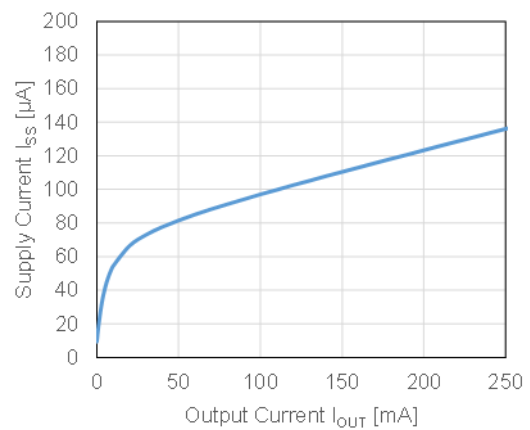

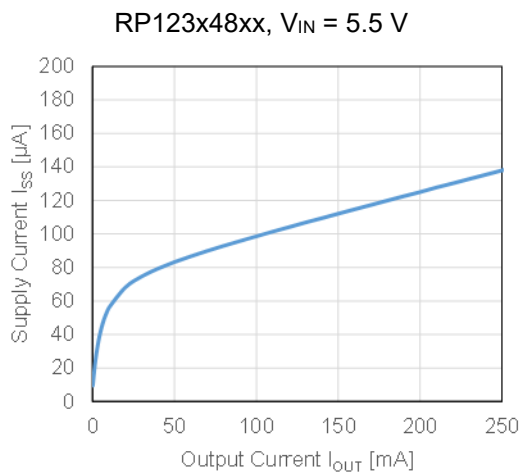

10) Ripple Rejection vs Frequency ($C_{OUT} = \text{Ceramic } 1.0\ \mu\text{F}$, Ripple = 0.2 Vp-p, $T_a = 25^\circ\text{C}$)

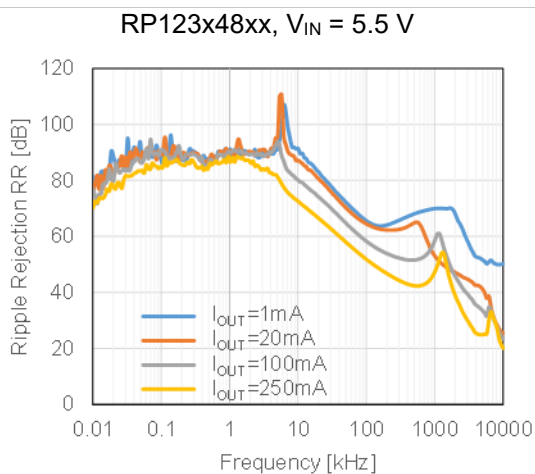
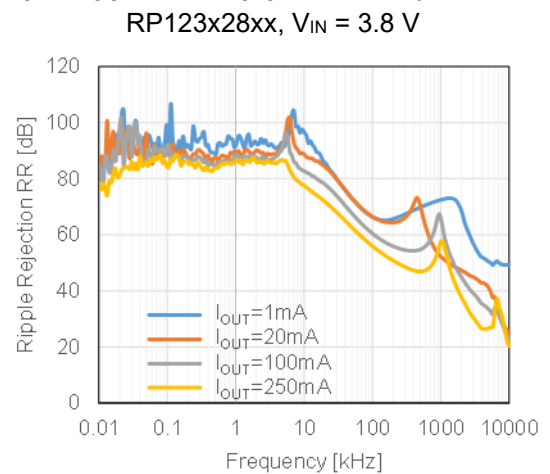
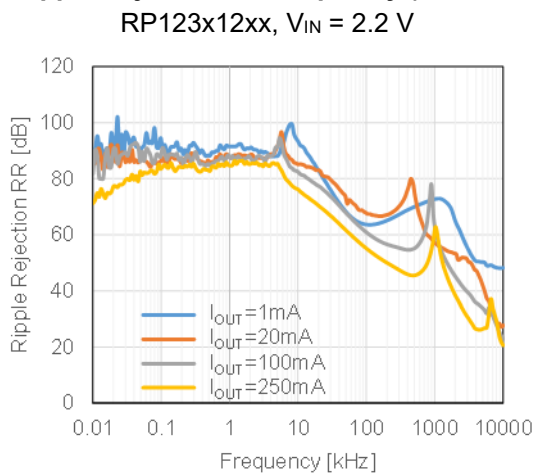

11) Ripple Rejection vs Input Bias Voltage (C_{OUT} = Ceramic 1.0 μ F, Ripple = 0.2 Vp-p, T_a = 25°C)

RP123x12xx, I_{OUT} = 1 mA

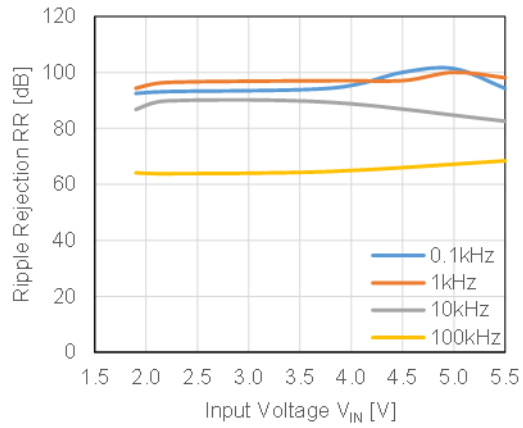

RP123x12xx, I_{OUT} = 20 mA

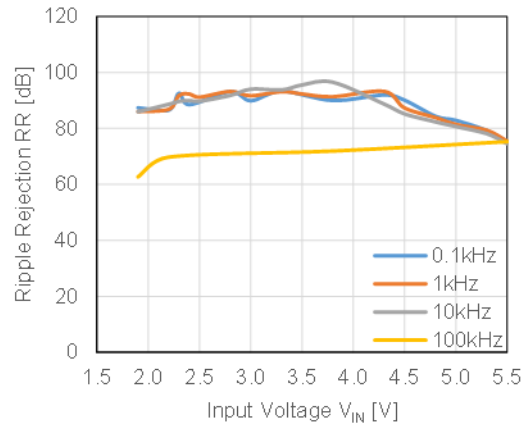

RP123x28xx, I_{OUT} = 1 mA

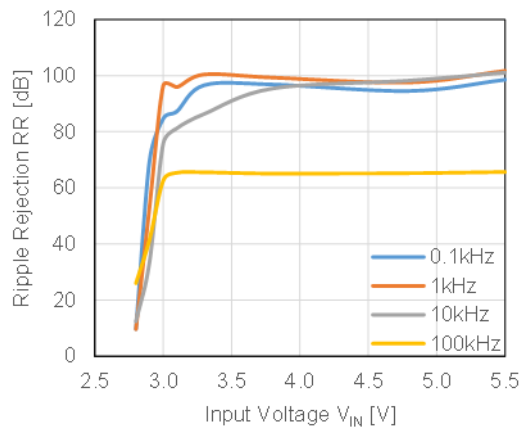

RP123x28xx, I_{OUT} = 20 mA

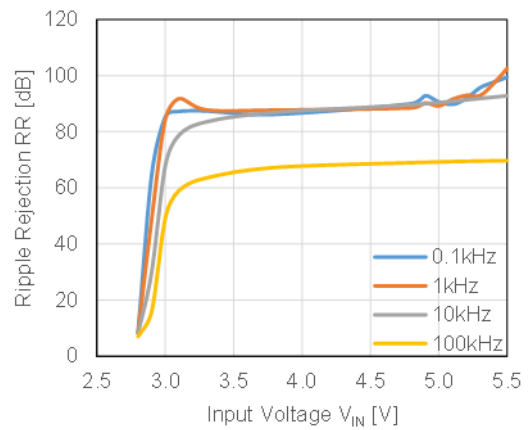

RP123x48xx, I_{OUT} = 1 mA

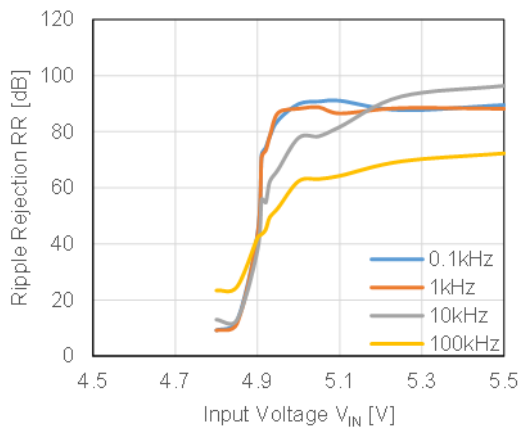

RP123x48xx, I_{OUT} = 20 mA

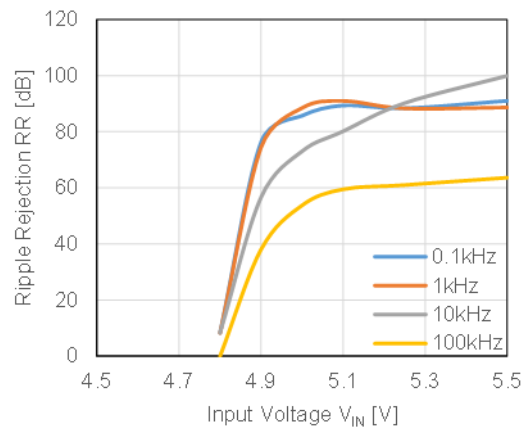

RP123x12xx, I_{OUT} = 100 mA

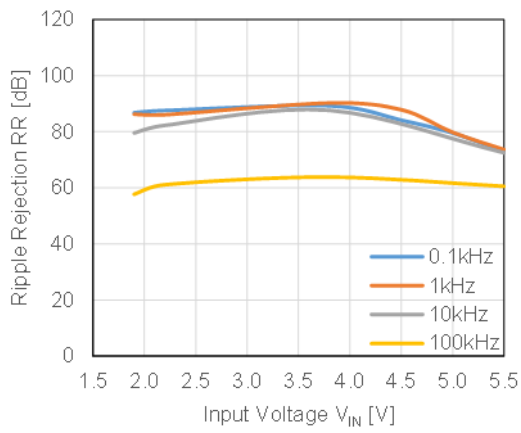

RP123x12xx, I_{OUT} = 250 mA

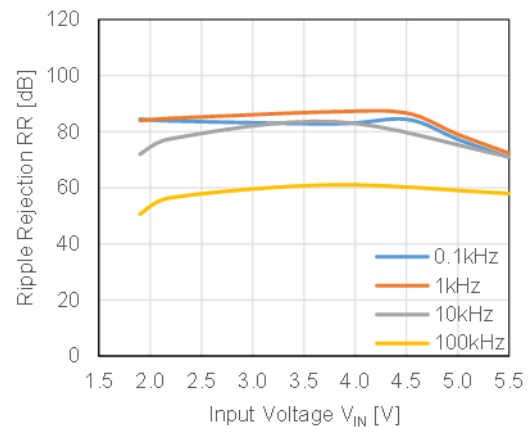

RP123x28xx, I_{OUT} = 100 mA

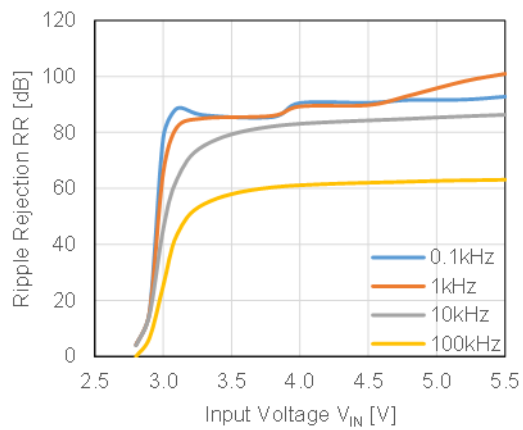

RP123x28xx, I_{OUT} = 250 mA

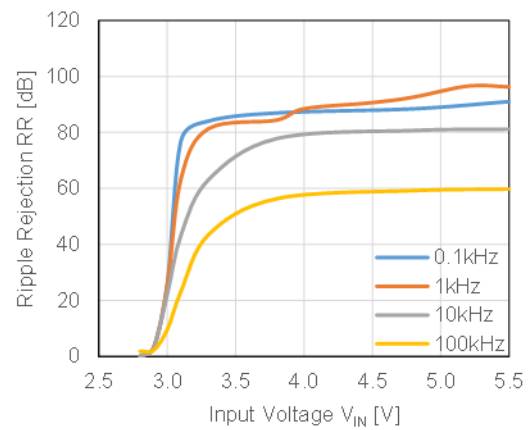

RP123x48xx, I_{OUT} = 100 mA

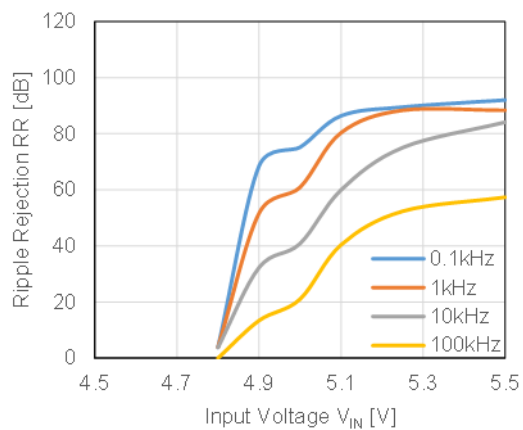

RP123x48xx, I_{OUT} = 250 mA

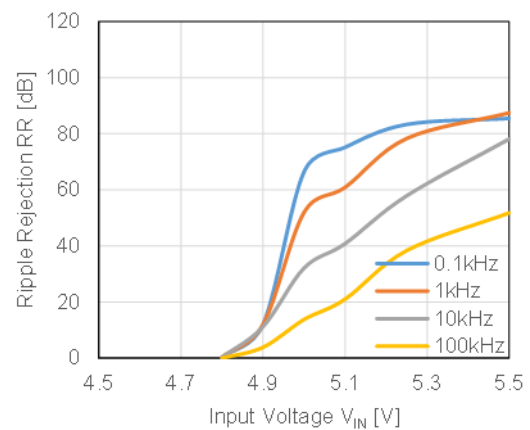

12) Output Noise Spectral Density vs Frequency (C_{IN} =Ceramic 1.0 μ F, C_{OUT} =Ceramic 1.0 μ F, T_a =25°C)

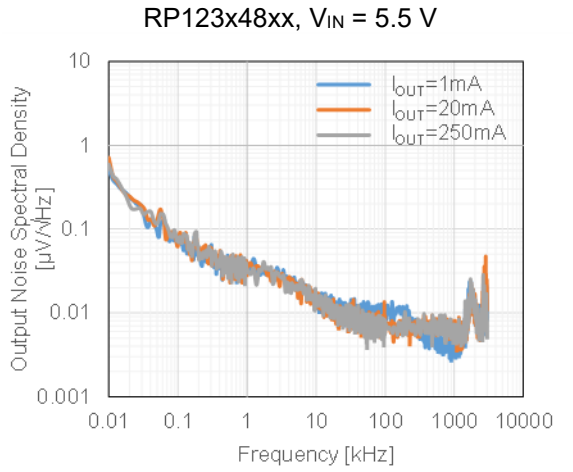
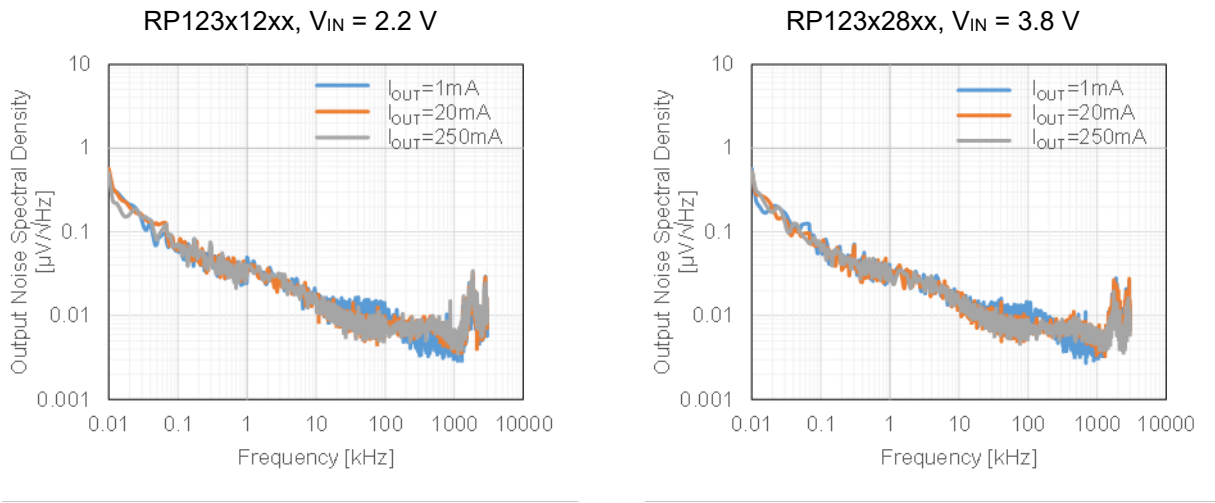

13) Input Transient Response ($C_{IN} =$ Ceramic 1.0 μ F, $C_{OUT} =$ Ceramic 1.0 μ F, $t_R = t_F = 5$ μ s, $T_a = 25$ °C)

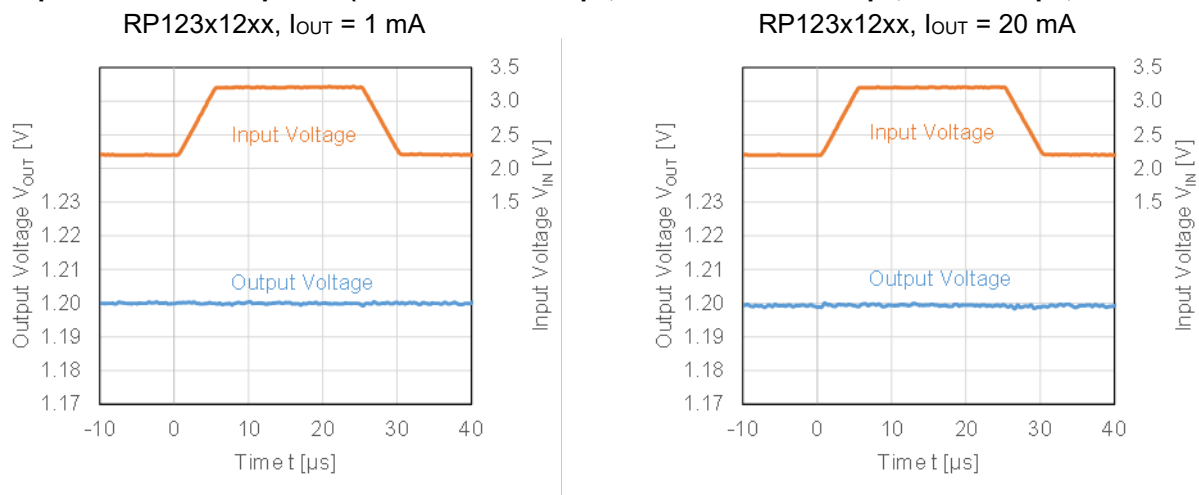

RP123x28xx, $I_{OUT} = 1 \text{ mA}$

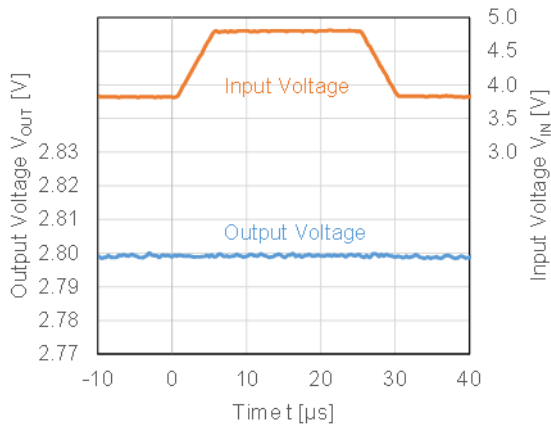

RP123x28xx, $I_{OUT} = 20 \text{ mA}$

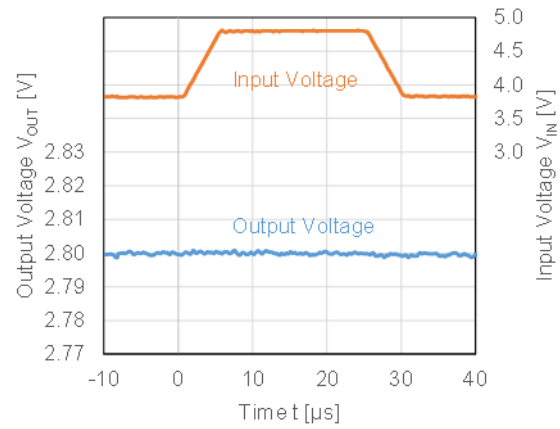

RP123x48xx, $I_{OUT} = 1 \text{ mA}$

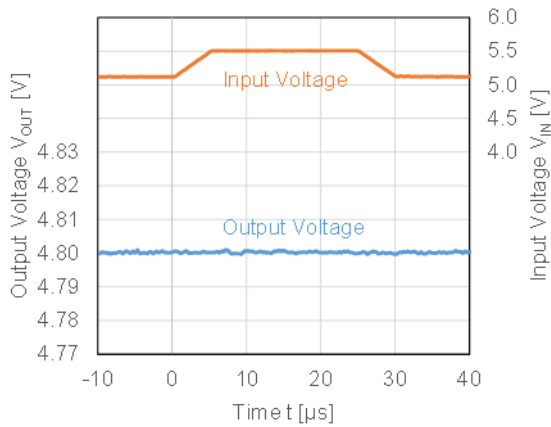

RP123x48xx, $I_{OUT} = 20 \text{ mA}$

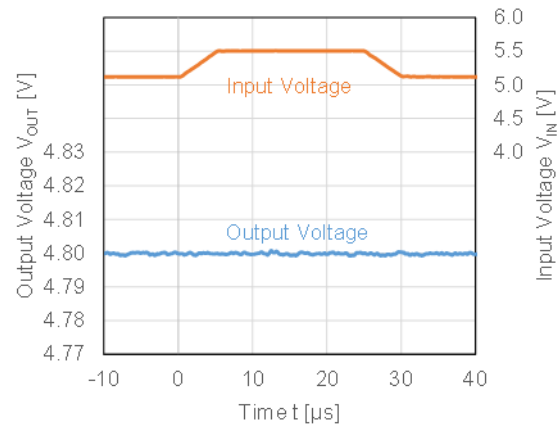

14) Load Transient Response ($C_{IN} = \text{Ceramic } 1.0 \mu\text{F}$, $C_{OUT} = \text{Ceramic } 1.0 \mu\text{F}$, $T_a = 25^\circ\text{C}$)

RP123x12xx, $V_{IN} = 2.2 \text{ V}$,
 $I_{OUT} = 1 \text{ mA} \Leftrightarrow 250 \text{ mA}$, $t_r = t_f = 10 \mu\text{s}$

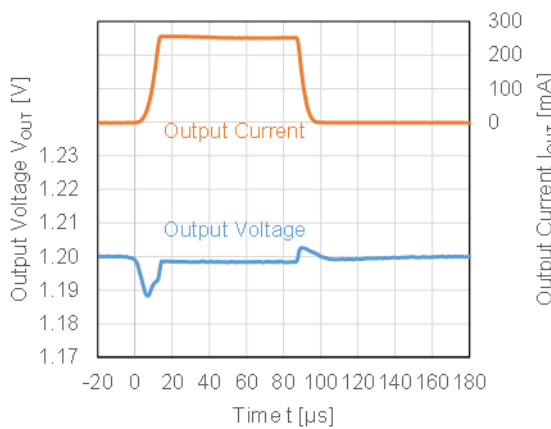

RP123x12xx, $V_{IN} = 2.2 \text{ V}$,
 $I_{OUT} = 0 \Rightarrow 100 \text{ mA}$, $t_r = 0.5 \mu\text{s}$

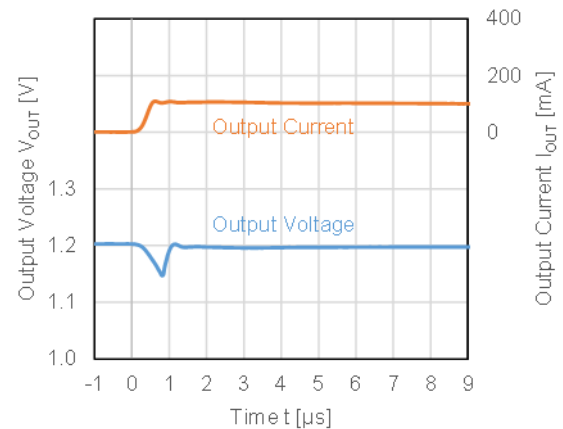

RP123x28xx, $V_{IN} = 3.8\text{ V}$,
 $I_{OUT} = 1\text{ mA} \Leftrightarrow 250\text{ mA}$, $t_R = t_F = 10\ \mu\text{s}$

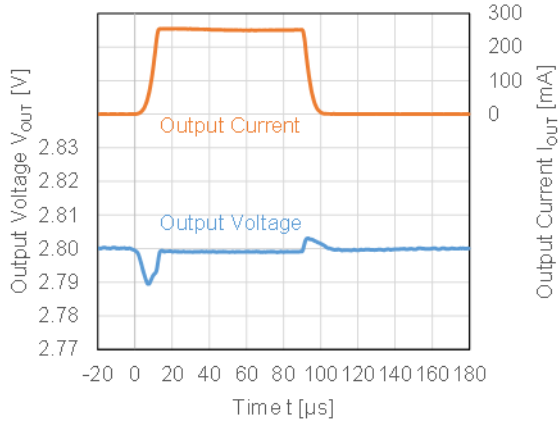

RP123x28xx, $V_{IN} = 3.8\text{ V}$,
 $I_{OUT} = 0 \Rightarrow 100\text{ mA}$, $t_R = 0.5\ \mu\text{s}$

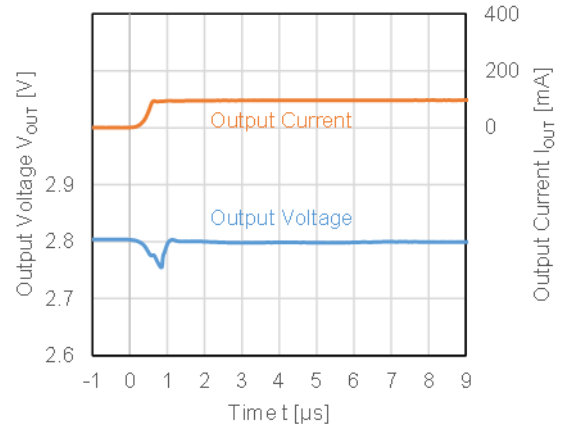

RP123x48xx, $V_{IN} = 5.5\text{ V}$,
 $I_{OUT} = 1\text{ mA} \Leftrightarrow 250\text{ mA}$, $t_R = t_F = 10\ \mu\text{s}$

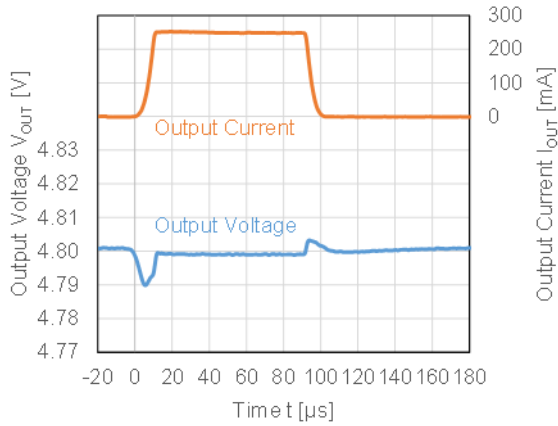

RP123x48xx, $V_{IN} = 5.5\text{ V}$,
 $I_{OUT} = 0 \Rightarrow 100\text{ mA}$, $t_R = 0.5\ \mu\text{s}$

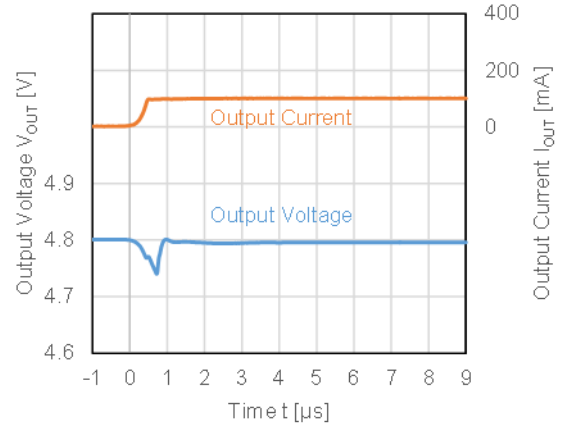

15) Turn On Speed with CE pin ($C_{IN} = \text{Ceramic } 1.0\ \mu\text{F}$, $C_{OUT} = \text{Ceramic } 1.0\ \mu\text{F}$, $T_a = 25^\circ\text{C}$)

RP123x12xx, $V_{IN} = 2.2\text{ V}$

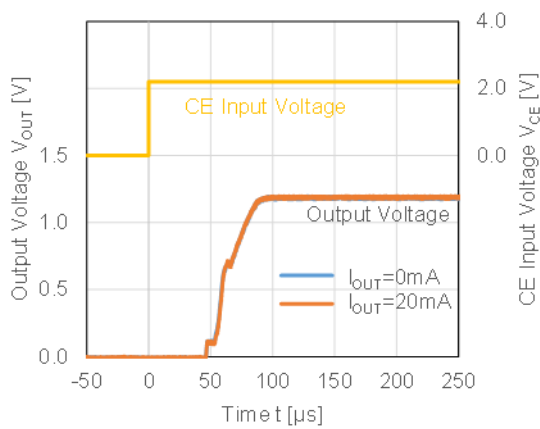

RP123x28xx, $V_{IN} = 3.8\text{ V}$

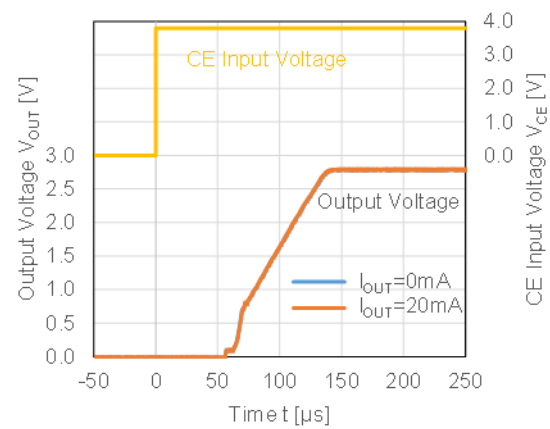

RP123x48xx, $V_{IN} = 5.5V$

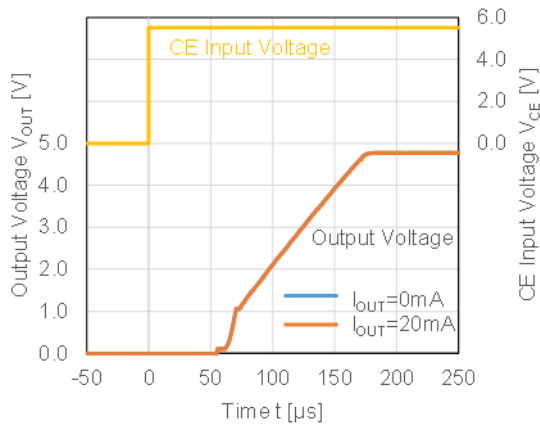

16) Turn Off Speed with CE pin ($C_{IN} = \text{Ceramic } 1.0 \mu F$, $C_{OUT} = \text{Ceramic } 1.0 \mu F$, $T_a = 25^\circ C$)

RP123x12xD, $V_{IN} = 2.2V$

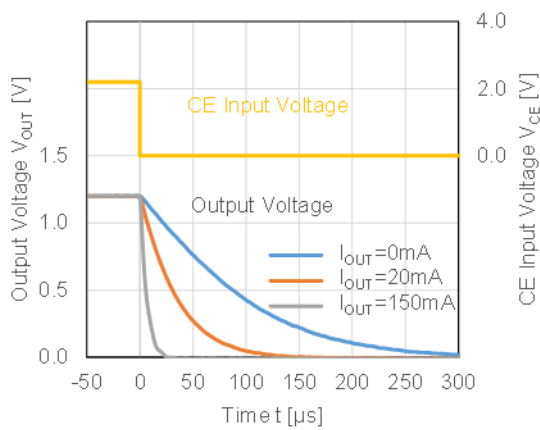

RP123x28xD, $V_{IN} = 3.8V$

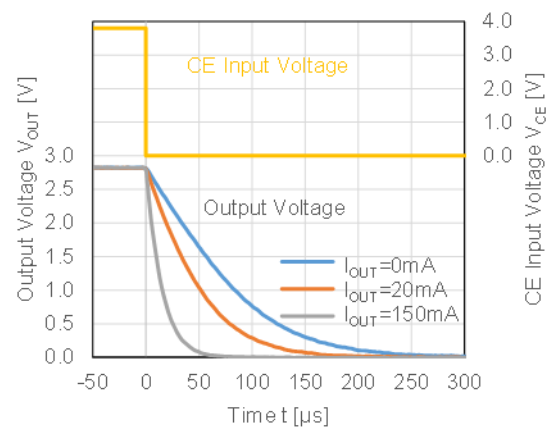

RP123x48xD, $V_{IN} = 5.5V$

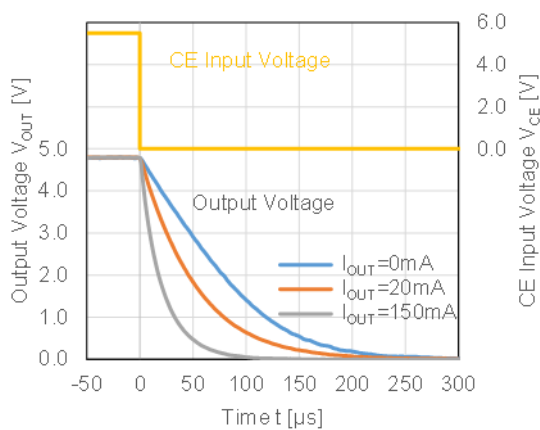

17) Inrush Current (C_{IN} = Ceramic 1.0 μF , I_{OUT} = 0 mA, T_a = 25°C)

RP123x12xx, V_{IN} = 2.2 V

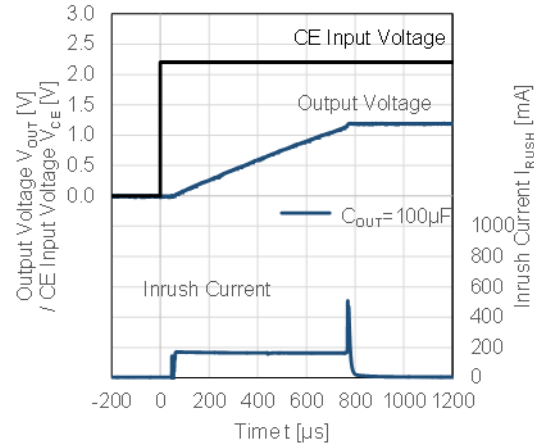
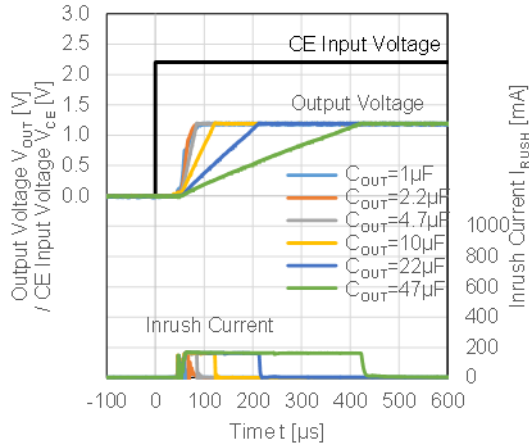

RP123x28xx, V_{IN} = 3.8 V

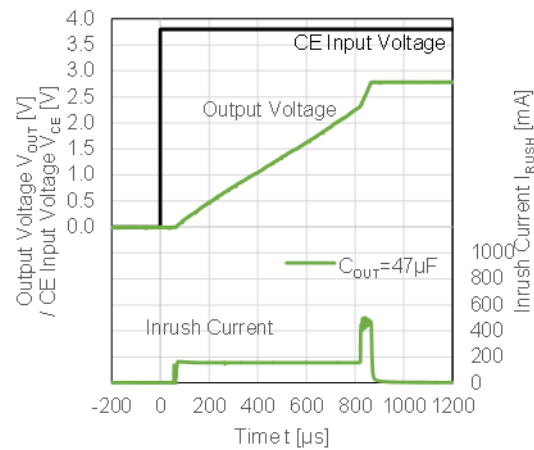
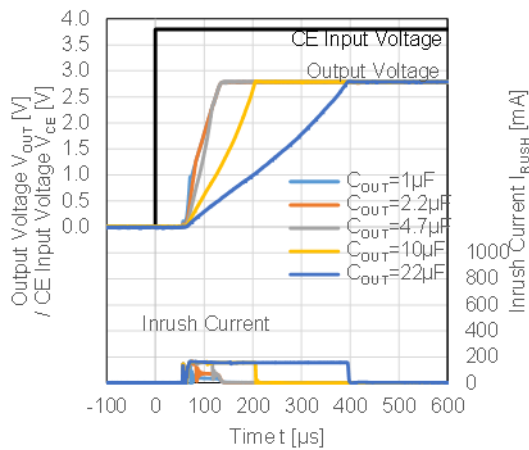

RP123x48xx, V_{IN} = 5.5 V

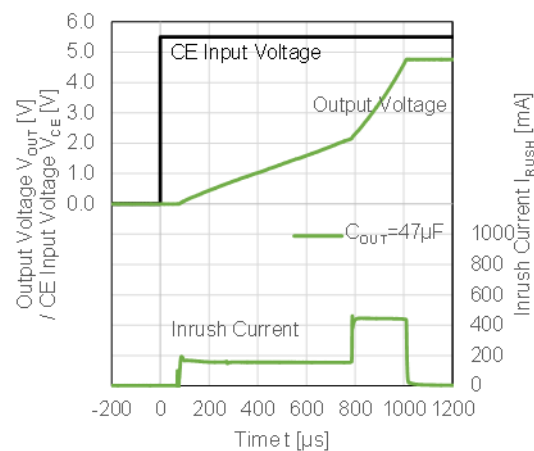
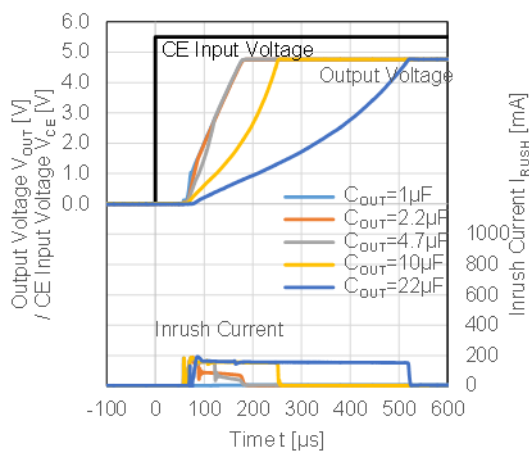

Test Circuit

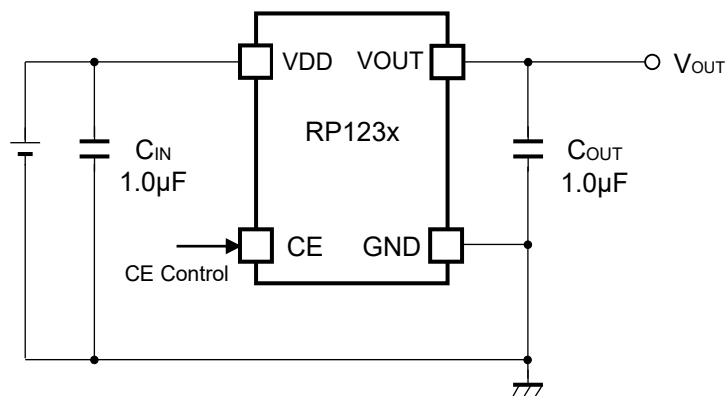

Test Circuit of Typical Characteristics

Measurement Components of Typical Characteristics

Symbol	Capacitance	Manufacture	Parts Number
C _{IN}	1.0 µF	Murata	GRM155R61A105KE15
C _{OUT}	1.0 µF	Murata	GRM155R61A105KE15

The power dissipation of the package is dependent on PCB material, layout, and environmental conditions. The following measurement conditions are based on JEDEC STD. 51-9.

Measurement Conditions

Item	Measurement Conditions
Environment	Mounting on Board (Wind Velocity = 0 m/s)
Board Material	Glass Cloth Epoxy Plastic (Four-Layer Board)
Board Dimensions	101.5 mm x 114.5 mm x 1.6 mm
Copper Ratio	Outer Layer (First Layer): 60% Inner Layers (Second and Third Layers): 100% Outer Layer (Fourth Layer): 60%

Measurement Result

(Ta = 25°C, Tjmax = 125°C)

Item	Measurement Result
Power Dissipation	520 mW
Thermal Resistance (θ_{ja})	$\theta_{ja} = 192^\circ\text{C/W}$

θ_{ja} : Junction-to-Ambient Thermal Resistance

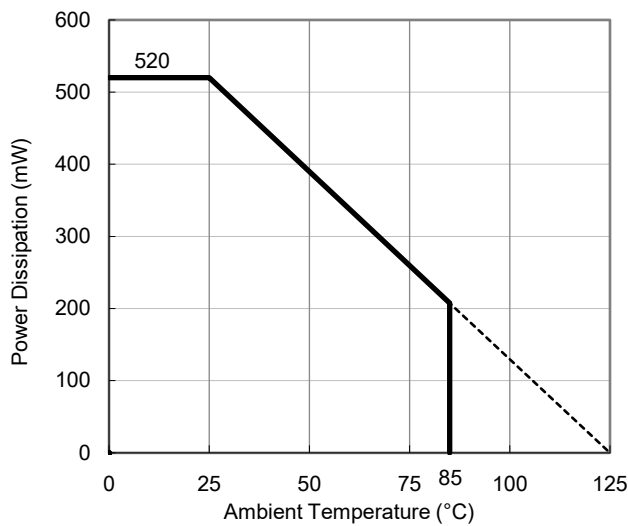

Power Dissipation vs. Ambient Temperature

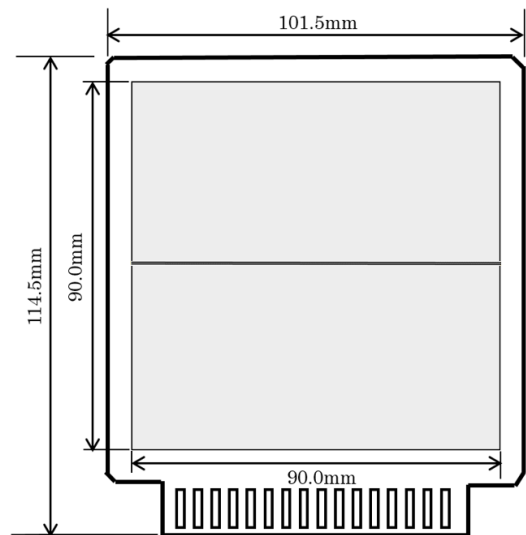

Measurement Board Pattern

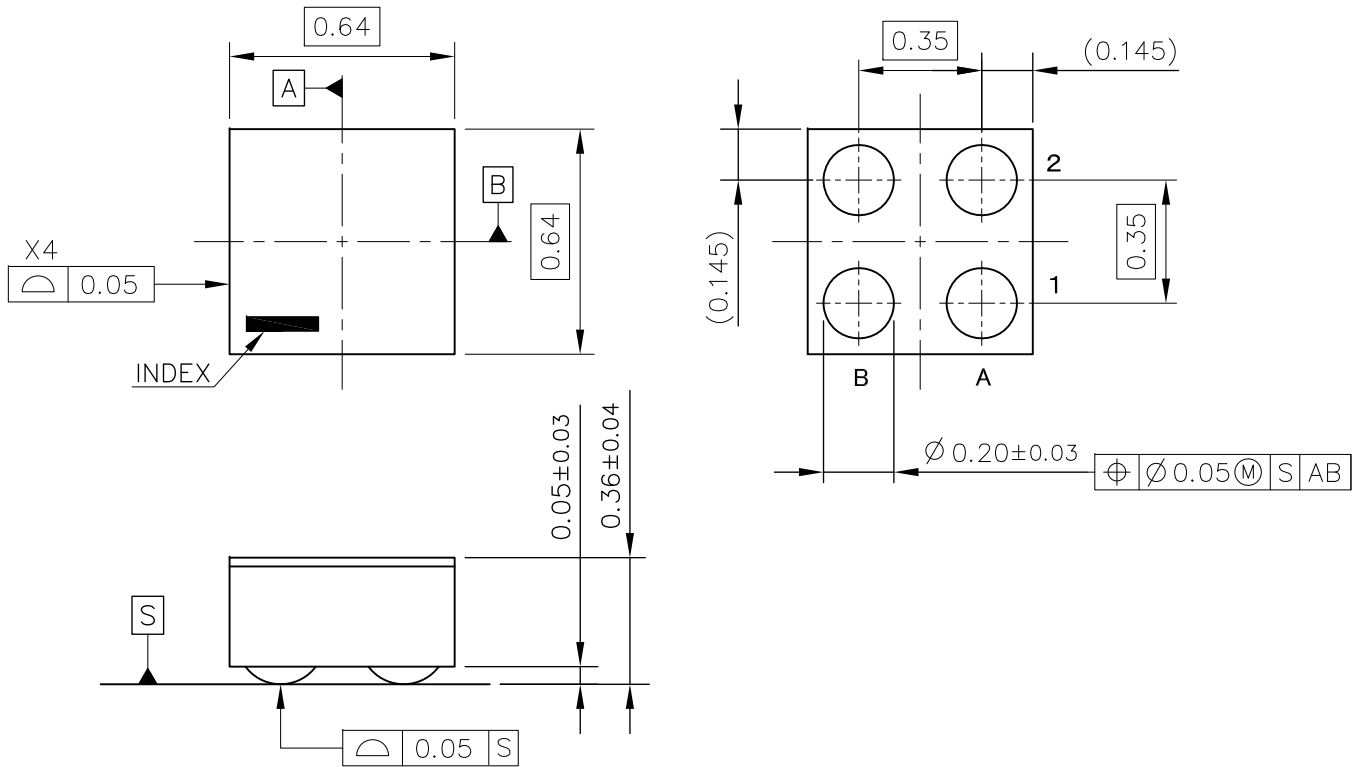

WLCSP-4-P8 Package Dimensions (Unit: mm)

The power dissipation of the package is dependent on PCB material, layout, and environmental conditions. The following measurement conditions are based on JEDEC STD. 51.

Measurement Conditions

Item	Measurement Conditions
Environment	Mounting on Board (Wind Velocity = 0 m/s)
Board Material	Glass Cloth Epoxy Plastic (Four-Layer Board)
Board Dimensions	101.5 mm x 114.5 mm x 1.6 mm
Copper Ratio	Outer Layer (First Layer): 60% Inner Layers (Second and Third Layers): 100% Outer Layer (Fourth Layer): 60%

Measurement Result

(Ta = 25°C, Tjmax = 125°C)

Item	Measurement Result
Power Dissipation	520 mW
Thermal Resistance (θ_{ja})	$\theta_{ja} = 192^\circ\text{C/W}$

θ_{ja} : Junction-to-Ambient Thermal Resistance

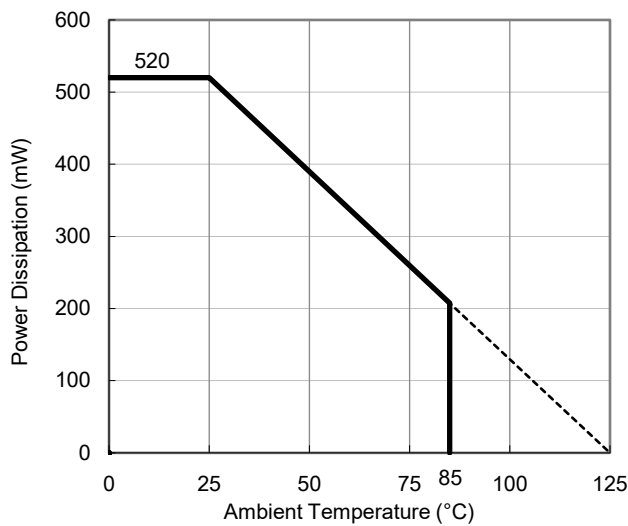

Power Dissipation vs. Ambient Temperature

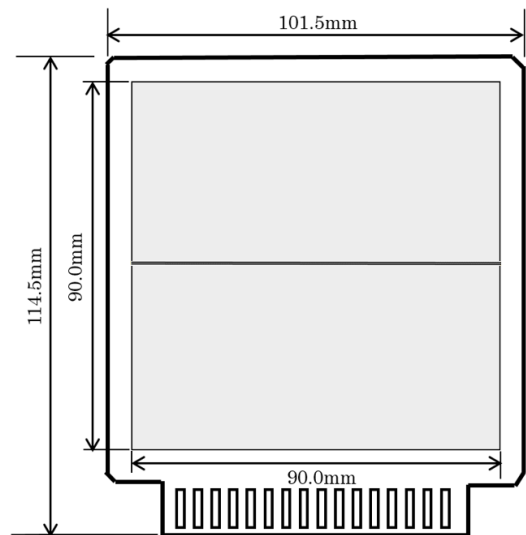

Measurement Board Pattern

PACKAGE DIMENSIONS

WLCSP-4-P12

DM-WLCSP-4-P12-JE-A

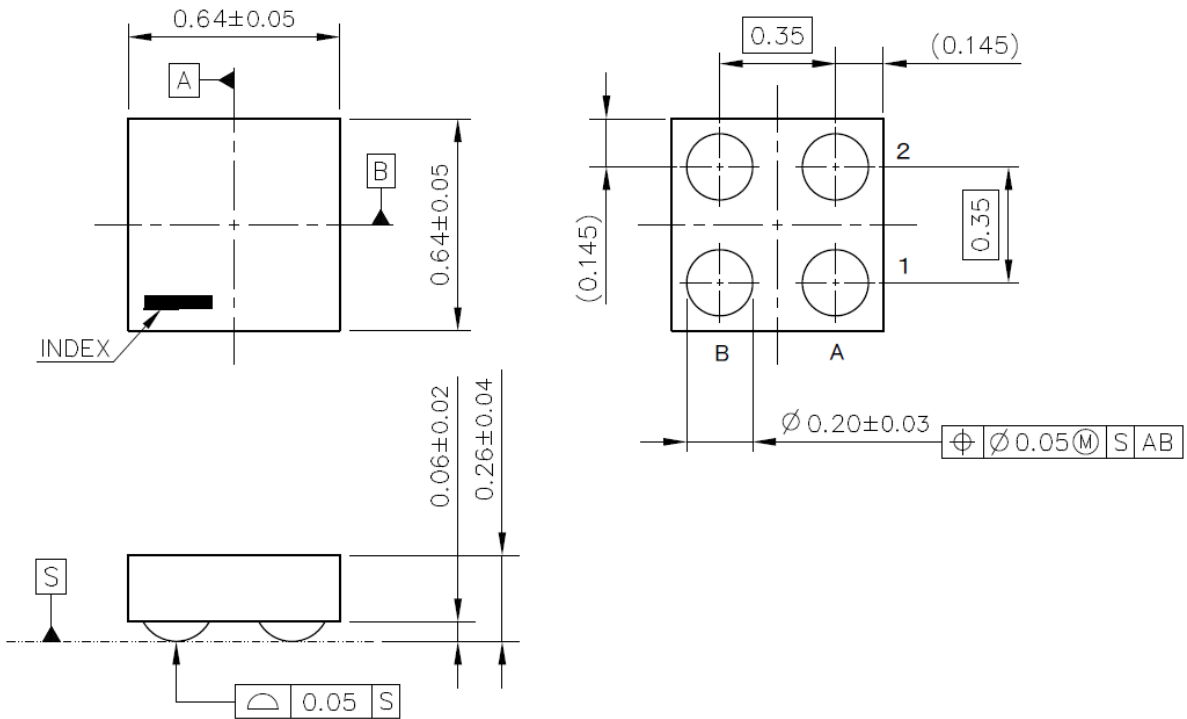

UNIT: mm

WLCSP-4-P12 Package Dimensions

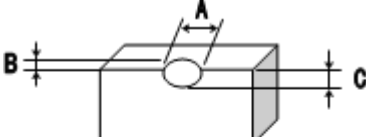
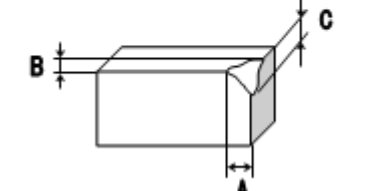
No.	Inspection Items	Inspection Criteria	Figure
1	Package chipping	A \geq 0.2mm is rejected B \geq 0.2mm is rejected C \geq 0.2mm is rejected And, Package chipping to Si surface and to bump is rejected.	
2	Si surface chipping	A \geq 0.2mm is rejected B \geq 0.2mm is rejected C \geq 0.2mm is rejected But, even if A \geq 0.2mm, B \leq 0.1mm is acceptable.	
3	No bump	No bump is rejected.	
4	Marking miss	To reject incorrect marking, such as another product name marking or another lot No. marking.	
5	No marking	To reject no marking on the package.	
6	Reverse direction of marking	To reject reverse direction of marking character.	
7	Defective marking	To reject unreadable marking. (Microscope: X15/ White LED/ Viewed from vertical direction)	
8	Scratch	To reject unreadable marking character by scratch. (Microscope: X15/ White LED/ Viewed from vertical direction)	
9	Stain and Foreign material	To reject unreadable marking character by stain and foreign material. (Microscope: X15/ White LED/ Viewed from vertical direction)	

The power dissipation of the package is dependent on PCB material, layout, and environmental conditions. The following measurement conditions are based on JEDEC STD. 51-7.

Measurement Conditions

Item	Measurement Conditions
Environment	Mounting on Board (Wind Velocity = 0 m/s)
Board Material	Glass Cloth Epoxy Plastic (Four-Layer Board)
Board Dimensions	76.2 mm × 114.3 mm × 0.8 mm
Copper Ratio	Outer Layer (First Layer): Less than 95% of 50 mm Square Inner Layers (Second and Third Layers): Approx. 100% of 50 mm Square Outer Layer (Fourth Layer): Approx. 100% of 50 mm Square
Through-holes	φ 0.2 mm × 11 pcs

Measurement Result

(Ta = 25°C, Tjmax = 125°C)

Item	Measurement Result
Power Dissipation	550 mW
Thermal Resistance (θ_{ja})	$\theta_{ja} = 180^\circ\text{C/W}$
Thermal Characterization Parameter (ψ_{jt})	$\psi_{jt} = 105^\circ\text{C/W}$

θ_{ja} : Junction-to-Ambient Thermal Resistance

ψ_{jt} : Junction-to-Top Thermal Characterization Parameter

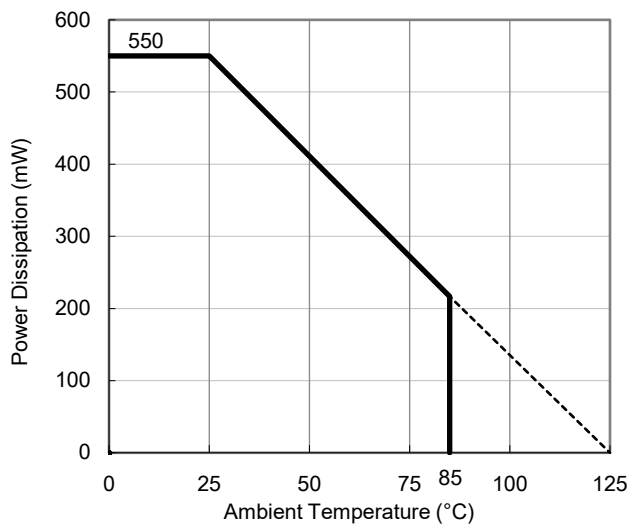

Power Dissipation vs. Ambient Temperature

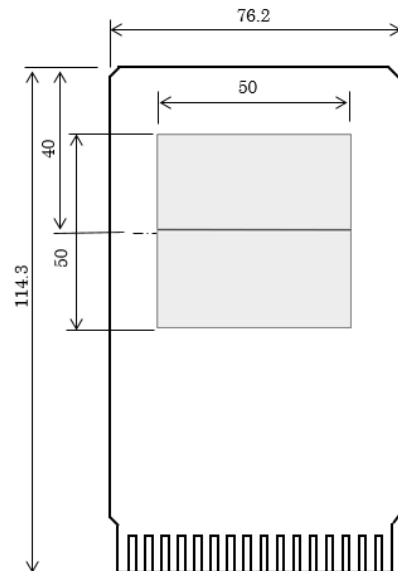

Measurement Board Pattern

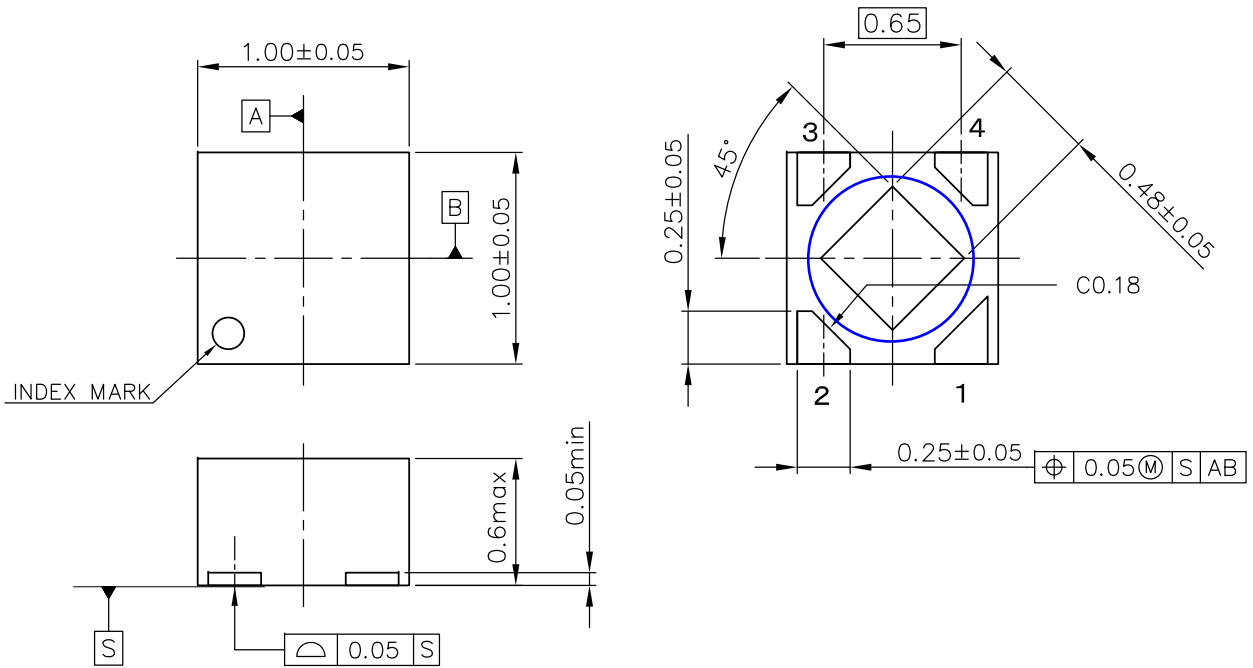

UNIT: mm

DFN(PLP)1010-4 Package Dimensions

* The tab on the bottom of the package shown by blue circle is a substrate potential (GND). It is recommended that this tab be connected to the ground plane on the board but it is possible to leave the tab floating.



1. The products and the product specifications described in this document are subject to change or discontinuation of production without notice for reasons such as improvement. Therefore, before deciding to use the products, please refer to Ricoh sales representatives for the latest information thereon.
2. The materials in this document may not be copied or otherwise reproduced in whole or in part without prior written consent of Ricoh.
3. Please be sure to take any necessary formalities under relevant laws or regulations before exporting or otherwise taking out of your country the products or the technical information described herein.
4. The technical information described in this document shows typical characteristics of and example application circuits for the products. The release of such information is not to be construed as a warranty of or a grant of license under Ricoh's or any third party's intellectual property rights or any other rights.
5. The products listed in this document are intended and designed for use as general electronic components in standard applications (office equipment, telecommunication equipment, measuring instruments, consumer electronic products, amusement equipment etc.). Those customers intending to use a product in an application requiring extreme quality and reliability, for example, in a highly specific application where the failure or misoperation of the product could result in human injury or death (aircraft, spacevehicle, nuclear reactor control system, traffic control system, automotive and transportation equipment, combustion equipment, safety devices, life support system etc.) should first contact us.
6. We are making our continuous effort to improve the quality and reliability of our products, but semiconductor products are likely to fail with certain probability. In order to prevent any injury to persons or damages to property resulting from such failure, customers should be careful enough to incorporate safety measures in their design, such as redundancy feature, fire containment feature and fail-safe feature. We do not assume any liability or responsibility for any loss or damage arising from misuse or inappropriate use of the products.
7. Anti-radiation design is not implemented in the products described in this document.
8. The X-ray exposure can influence functions and characteristics of the products. Confirm the product functions and characteristics in the evaluation stage.
9. WLCSP products should be used in light shielded environments. The light exposure can influence functions and characteristics of the products under operation or storage.
10. There can be variation in the marking when different AOI (Automated Optical Inspection) equipment is used. In the case of recognizing the marking characteristic with AOI, please contact Ricoh sales or our distributor before attempting to use AOI.
11. Please contact Ricoh sales representatives should you have any questions or comments concerning the products or the technical information.



Ricoh is committed to reducing the environmental loading materials in electrical devices with a view to contributing to the protection of human health and the environment.

Ricoh has been providing RoHS compliant products since April 1, 2006 and Halogen-free products since April 1, 2012.

RICOH RICOH ELECTRONIC DEVICES CO., LTD.

Official website

<https://www.n-redc.co.jp/en/>

Contact us

<https://www.n-redc.co.jp/en/buy/>

