

Complementary Output Hall Effect Fan Driver

❖ GENERAL DESCRIPTION

MA7220 is integrated Hall sensors with output drivers, mainly designed for electronic commutation of brush-less DC Fan. This IC is using HV BCD process internally includes the regulator, protecting diode, Hall plate, amplifier, comparator, and a pair of complementary open-Drain outputs (DO, DOB).

To avoid coil burning, rotor-lock shutdown detection circuit shut down the output driver if the rotor is blocked and then the automatic recovery circuit will try to restart the motor. This function repeats while rotor is blocked. Until the blocking is removed, the motor recovers running normally.

❖ FEATURES

- Built-in protecting diode only for chip reverse power connecting
- Wide operating voltage range: 3.5V~28V
- Output sink current up to 0.3A
- On-Chip High sensitivity Hall-effect Sensor
- Thermal Shutdown Protection
- -40°C to 85°C Operating Temperature range
- Rotor-locked shutdown and automatically restart function
- For 12V and 24V DC motor / FAN systems
- Low Profile SIP-4L Package

❖ PIN ASSIGNMENT

The package of MA7220 is SIP-4L; the pin assignment is given by:

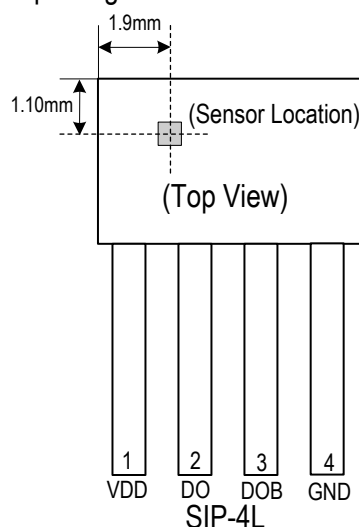

Name	Description
VDD	Supply Voltage
DO	Output 1
DOB	Output 2
GND	Ground.

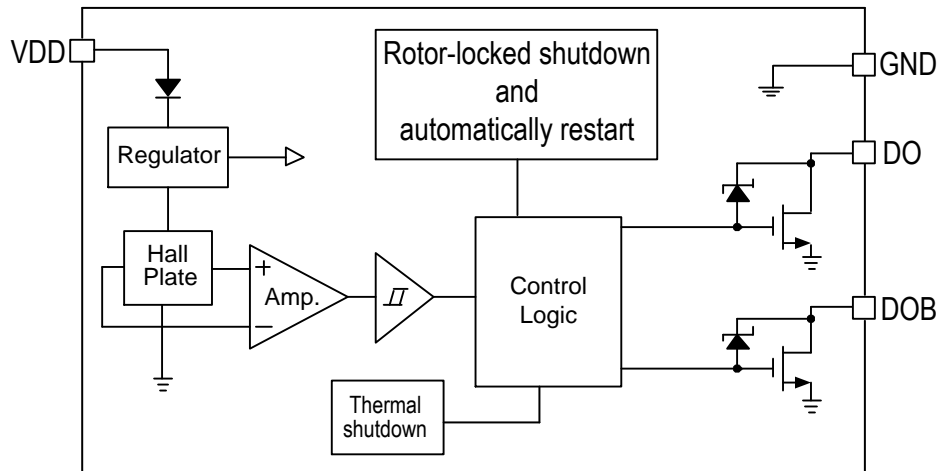
❖ BLOCK DIAGRAM

❖ RDER/MARKING INFORMATION

Order Information	Top Marking
<p>MA7220 XX X</p> <p>Package Type: P4: SIP-4L</p> <p>Packing: Blank: Bag</p>	<p>7 2 2 0 → Part number</p> <p>Y Y WW X → ID code: internal</p> <p>WW: 01~52</p> <p>Year: 15=2015</p>

❖ ABSOLUTE MAXIMUM RATINGS (at T_A=25°C)

Characteristics	Symbol	Rating	Unit
Supply Voltage	V _{CC}	30	V
Reverse VCC Polarity Voltage	V _{RCC}	-30	V
Magnetic Flux Density	B	Unlimited	Gauss
Output Current	I _o	300	mA
		500	
		700	
Power Dissipation	P _D	550	mW
Storage Temperature Range	T _{STG}	-65 to +150	°C
Junction Temperature	T _J	150	°C
Thermal Resistance from Junction to case	θ _{JC}	49	°C/W
Thermal Resistance from Junction to ambient	θ _{JA}	227	°C/W
Operating temperature Range	T _O	-40 to 85	°C

❖ ELECTRICAL CHARACTERISTICS

 (V_{DD} = 12V, T_A = +25°C, unless otherwise noted.)

Characteristics	Symbol	Conditions	Min	Typ	Max	Units
Supply Voltage	V _{DD}	Operating	3.5	-	28	V
Supply current	I _{DD}	Operating	-	3.5	5	mA
Output Leakage Current	I _{OFF}	V _{OUT} =12V	-	< 0.1	10	μA
Output On resistance	R _{DS(ON)}	I _{OUT} =200mA	-	2.4	-	Ω
Output Clamping Voltage	V _Z	DO, DOB	-	58	-	V
Locked Protection On	T _{lrp-on}		-	0.40	-	Sec
Locked Protection Off	T _{lrp-off}		-	2.4	-	Sec
Thermal shutdown Temp	T _{SD}		150	-	-	°C
Thermal Shutdown Hysteresis	T _{SH}		-	30	-	°C
Magnetic			(1mT=10 Gauss)			
Operate Point	B _{OP}		5	30	50	Gauss
Release Point	B _{RP}		-50	-30	-5	Gauss
Hysteresis	B _{HYS}		-	60	-	Gauss

Driver output vs. magnetic pole

Characteristics	Test Conditions	DO	DOB
North pole	B < Brp	High	Low
South pole	B > Bop	Low	High

Note: The magnetic pole is applied facing the branded side of the package

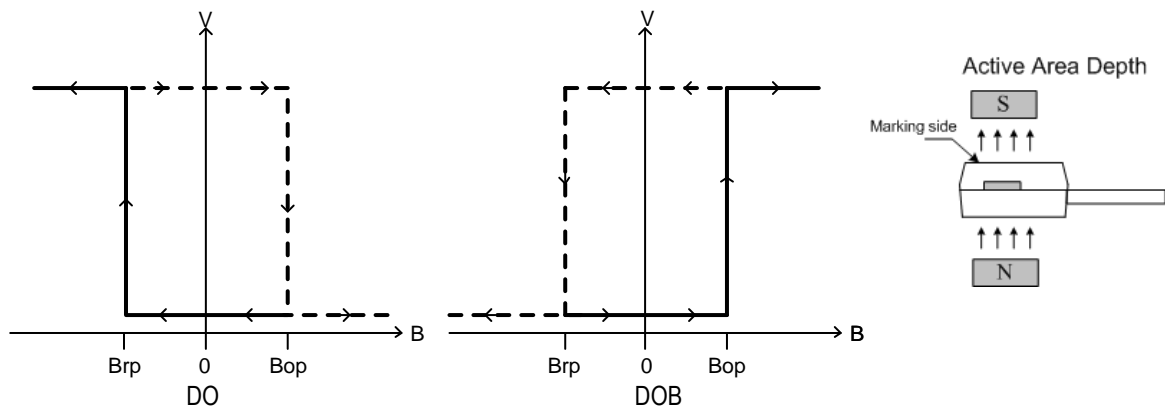

❖ APPLICATION CIRCUIT

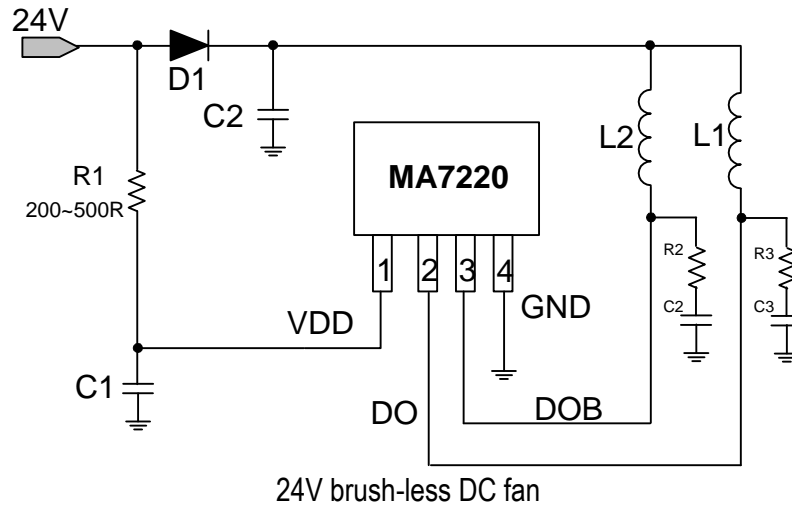

Note1: C2(Optional) is for power stabilization, Recommended E-Cap 2.2uF/50V and D1 (Optional) is a reverse protect diode.

Note2: R1(1/8W 0805) and C1(100nF) : Enhance the reliability during hot swap.

Note3: Recommended to use a 47 ohm for R2 & R3 and a 1uF E-Cap for C2 & C3. These values may need to be optimized depending on the coil used.

❖ PERFORMANCE CHARACTERISTICS

T_A (°C)	25	50	60	70	80	85	90	95	100
PD (mW)	550	440	396	352	308	286	264	242	220
T_A (°C)	105	110	115	120	125	130	135	140	150
PD (mW)	198	176	154	132	110	88	66	44	0

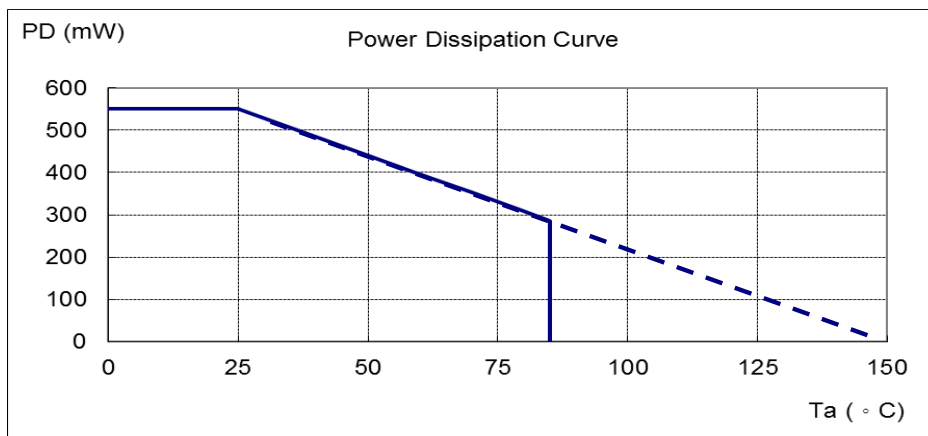

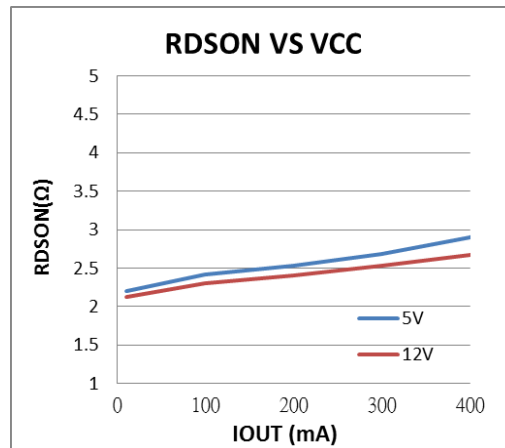
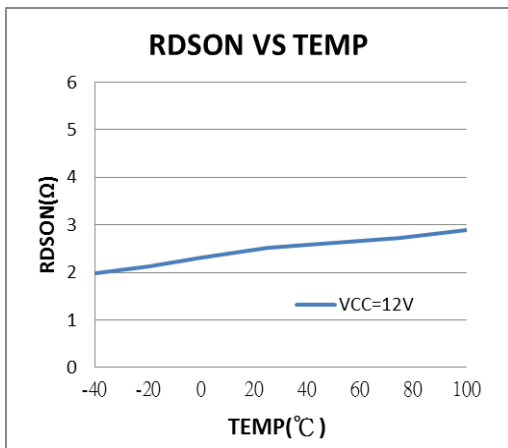
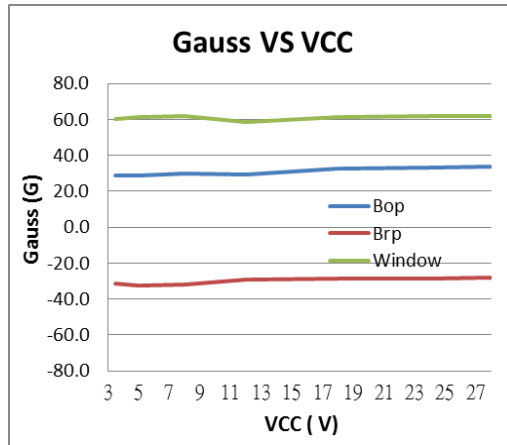
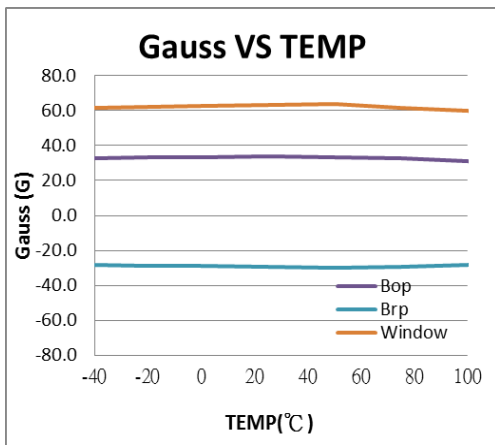
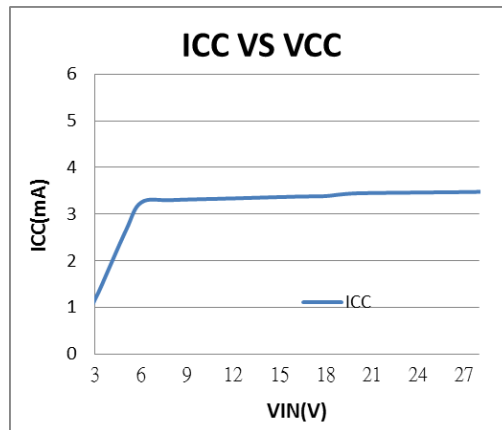
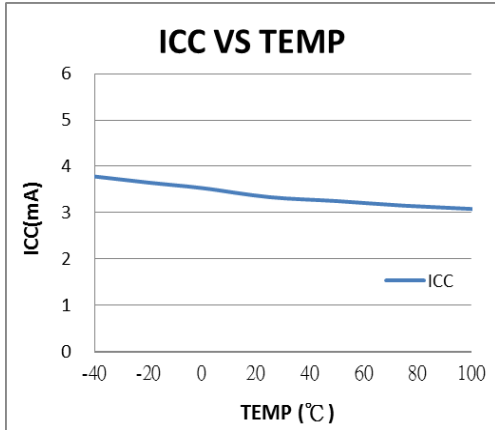

❖ PACKAGE OUTLINES
