

## Single Output Hall Effect Latch

### ❖ GENERAL DESCRIPTION

MA7021 is an integrated Hall effect latched sensor designed for electronic commutation of brush-less DC motor applications. The device is using HV BCD process includes an on-chip Hall voltage generator for magnetic sensing, a comparator that amplifies the Hall voltage, and a Schmitt trigger to provide switching hysteresis for noise rejection, and open-collector output. An internal band-gap regulator is used to provide temperature compensated supply voltage for internal circuits and allows a wide operating supply range.

If a magnetic flux density larger than threshold  $B_{op}$ , OUT is turned on(low). The output state is held until a magnetic flux density reversal falls below  $B_{rp}$  causing OUT to be turned off (high).

### ❖ FEATURES

- 2.5V to 26V DC operation voltage
- Temperature compensation
- Wide operating voltage range
- Open-Drain pre-driver
- 25mA maximum sinking output current.
- Low Profile TSOT/SOT23-3L , SIP-3L(TO-92S) and DFN1.6x1.6-6L Package

### ❖ PIN ASSIGNMENT

The package of MA7021 ; the pin assignment is given by:

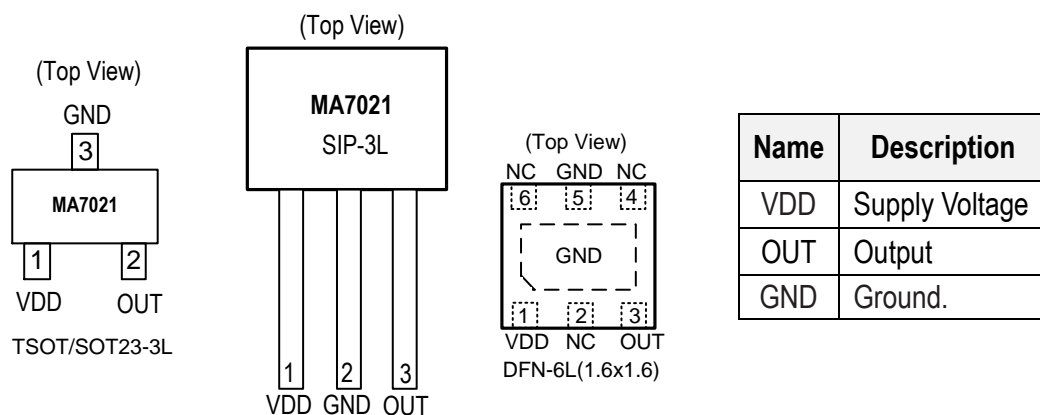

Name	Description
VDD	Supply Voltage
OUT	Output
GND	Ground.

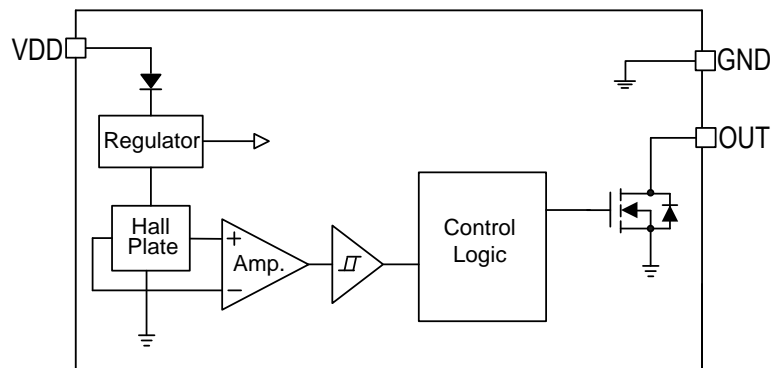
**❖ BLOCK DIAGRAM**

**❖ RDER/MARKING INFORMATION**

Order Information	Top Marking (SIP-3L)
<b>MA7021 XX X</b> Package Type P3: SIP-3L A :SOT23-3L AT:SOT23-3L D1:DFN1.6x1.6-6L Packing Blank: Bag A : Taping	<b>7021</b> → Part number <b>YYWWX</b> → ID code:internal WW:01~52 Year:18=2018
Top Marking (DFN)	Top Marking (TSOT/SOT23-3L)
<b>8 8 X</b> → Week: 01~26(A~Z) 27~52(a~z) <b>X X X</b> → ID Code: Internal	<b>H9 Y WX</b> → ID Code: Internal Week: 01~26(A~Z) 27~52(a~z) Year : 8 = 2018

**❖ ABSOLUTE MAXIMUM RATINGS (at T<sub>A</sub>=25°C)**

Characteristics	Symbol	Rating	Unit
Supply Voltage	V <sub>CC</sub>	28	V
Reverse VCC Polarity Voltage	V <sub>RCC</sub>	-28	V
Magnetic Flux Density	B	Unlimited	Gauss
Output Current	I <sub>O</sub>	25	mA
Power Dissipation(SIP3 /SOT23,DFN)	P <sub>D</sub>	550/230	mW
Storage Temperature Range	T <sub>STG</sub>	-65 to +150	°C
Thermal Resistance from Junction to case (SIP3 /SOT23,DFN)	θ <sub>JC</sub>	49/410	°C/W
Thermal Resistance from Junction to ambient (SIP3 /SOT23,DFN)	θ <sub>JA</sub>	227/543	°C/W
Junction temperature	T <sub>J</sub>	150	°C
Operating temperature	T <sub>O</sub>	-40 to 120	°C
Magnetic signal input frequency(note1)	F <sub>sw</sub>	0~3	kHz
Magnetic signal input frequency(note1)	F <sub>sw</sub>	0~3	kHz

Note1 : Not subject to production test, verified by design/characterization.

**❖ ELECTRICAL CHARACTERISTICS**

 ( $V_{DD} = 12V$ ,  $T_A = +25^\circ C$ , unless otherwise noted.)

Characteristics	Symbol	Conditions	Min	Typ	Max	Units
Supply Voltage	$V_{DD}$	Operating	2.5	-	26	V
Supply current	$I_{DD}$	Operating	-	2.0	3.0	mA
Output Leakage Current	$I_{OFF}$	$V_{OUT}=12V$	-	< 0.1	10	$\mu A$
Output Saturation Voltage	$V_{ds(sat)}$	$I_{OUT}=20mA$	-	0.3	-	V
<b>Magnetic</b>			(1mT=10 Gauss)			
Operate Point	$B_{OP}$		5	15	25	Gauss
Release Point	$B_{RP}$		-25	-15	-5	Gauss
Hysteresis	$B_{HYS}$		-	30	-	Gauss

Driver output vs. magnetic pole(SIP3)

Characteristics	Test Conditions	OUT
North pole	$B < Brp$	High
South pole	$B > Bop$	Low

Note: The magnetic pole is applied facing the branded side of the SIP3 package

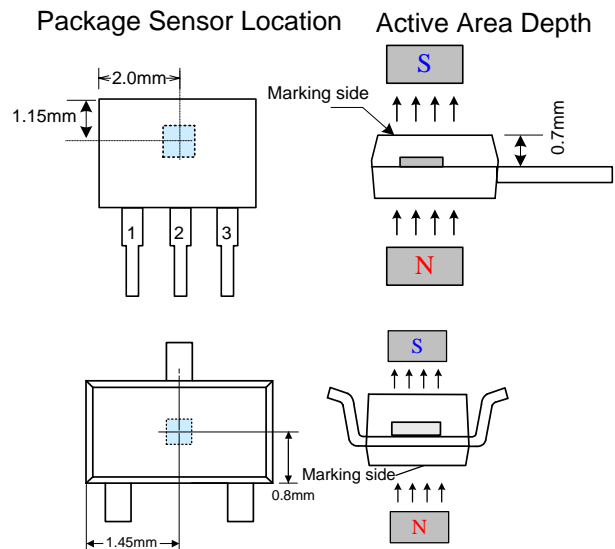
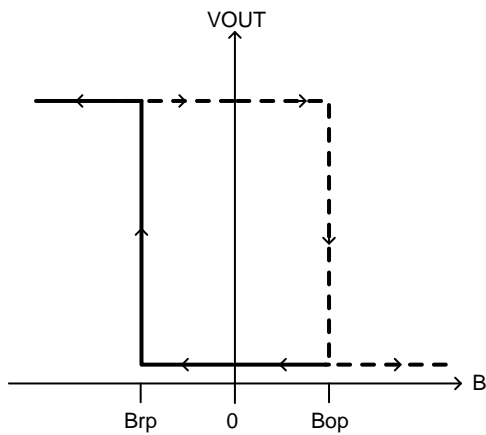
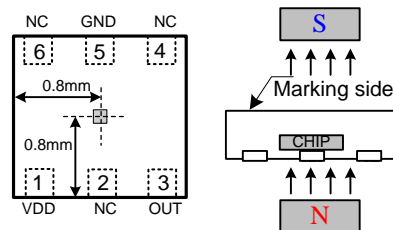
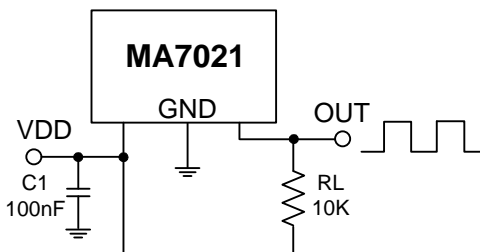
**❖ TEST CIRCUIT**

Note : C1 is for power stabilization and to strengthen the noise immunity. RL is the pull-up resistor.

**❖ PERFORMANCE CHARACTERISTICS**
**SIP-3L**

<b>T<sub>A</sub> (°C)</b>	<b>25</b>	<b>50</b>	<b>60</b>	<b>70</b>	<b>80</b>	<b>85</b>	<b>90</b>	<b>95</b>	<b>100</b>
Pd (mW)	550	440	396	352	308	286	264	242	220
<b>T<sub>A</sub> (°C)</b>	<b>105</b>	<b>110</b>	<b>115</b>	<b>120</b>	<b>125</b>	<b>130</b>	<b>135</b>	<b>140</b>	<b>150</b>
Pd (mW)	198	176	154	132	110	88	66	44	0

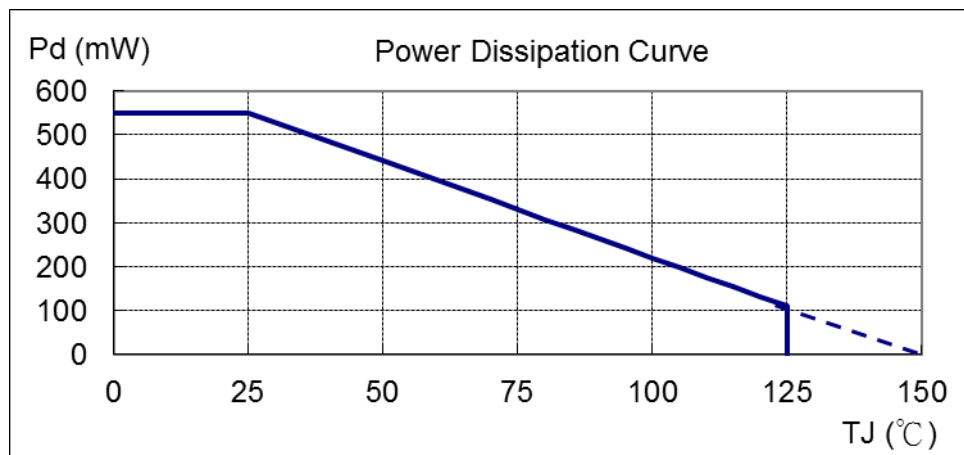
**SOT-23-3L**

<b>T<sub>A</sub> (°C)</b>	<b>25</b>	<b>50</b>	<b>60</b>	<b>70</b>	<b>80</b>	<b>85</b>	<b>90</b>	<b>95</b>	<b>100</b>
Pd (mW)	230	230	184	166	147	129	120	110	101
<b>T<sub>A</sub> (°C)</b>	<b>105</b>	<b>110</b>	<b>115</b>	<b>120</b>	<b>125</b>	<b>130</b>	<b>135</b>	<b>140</b>	<b>150</b>
Pd (mW)	83	74	64	55	46	37	27	18	0

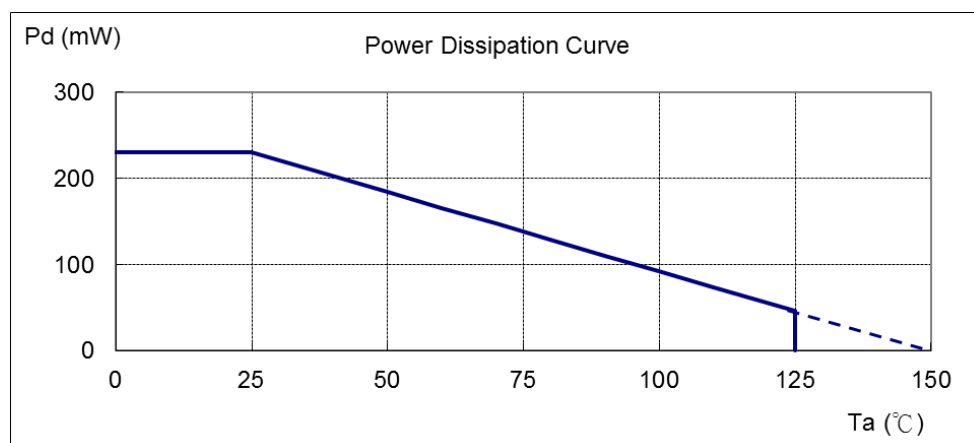

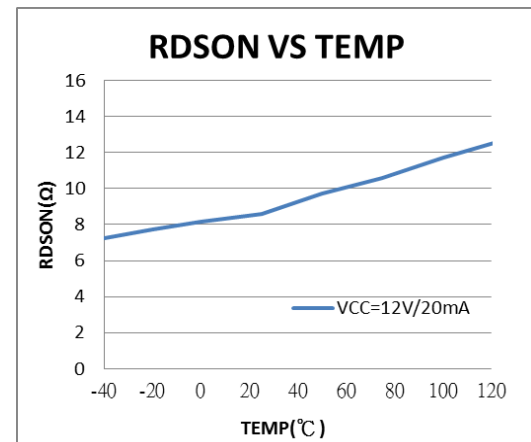
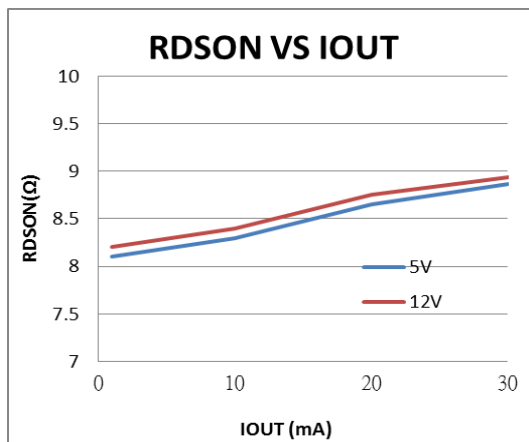
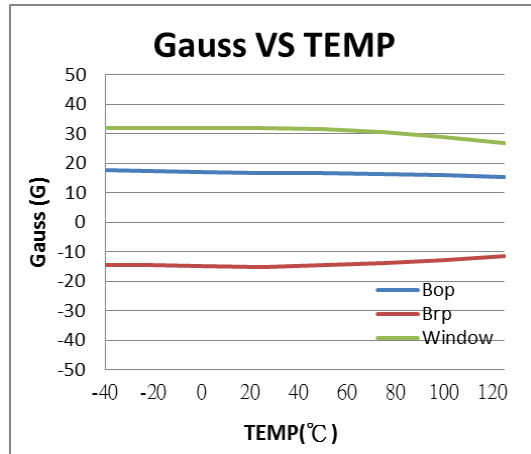
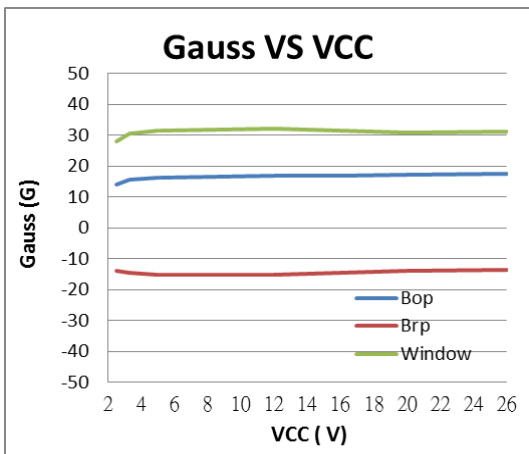
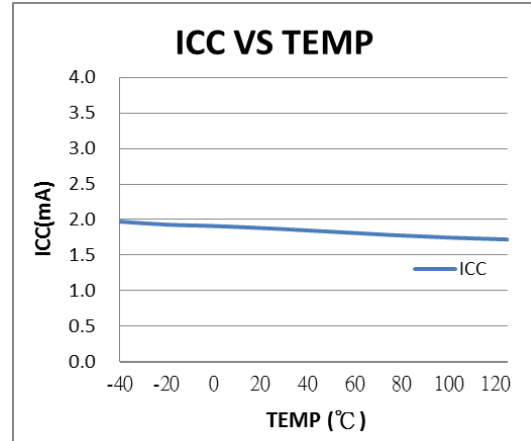
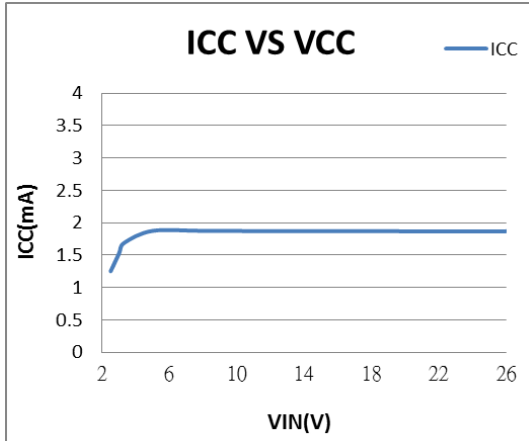
**❖ PERFORMANCE CHARACTERISTICS**

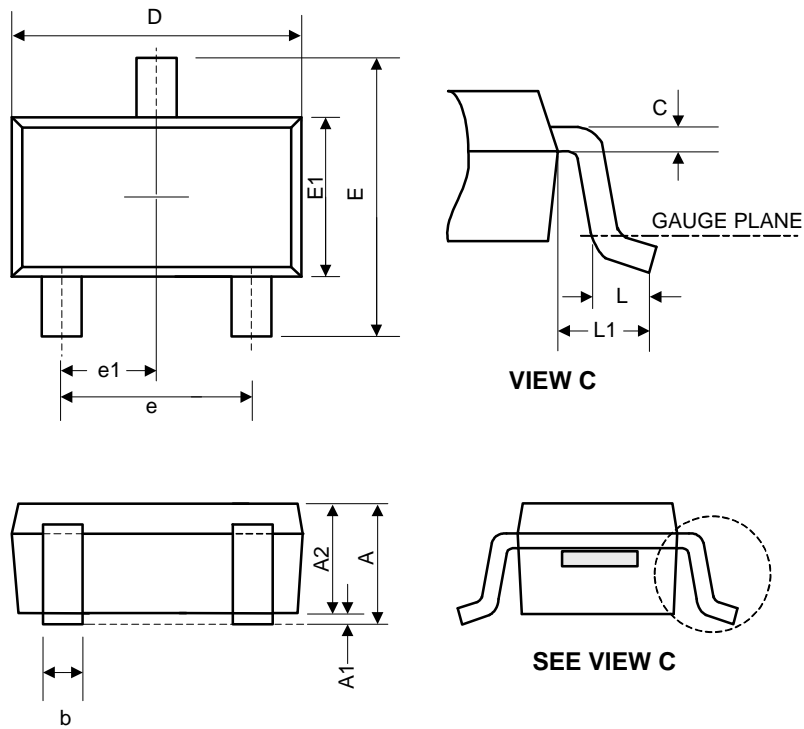
**❖ PACKAGE OUTLINES**
**(1) SOT-23-3L**

Symbol	Dimensions in Millimeters			Dimensions in Inches		
	Min.	Nom.	Max.	Min.	Nom.	Max.
A	-	-	1.45	-	-	0.057
A1	0	0.08	0.15	-	-	0.006
A2	0.9	1.1	1.3	0.035	0.043	0.051
b	0.3	0.4	0.5	0.012	0.016	0.02
C	0.08	0.15	0.22	0.003	0.006	0.009
D	2.7	2.9	3.1	0.106	0.114	0.122
E	2.6	2.8	3	0.102	0.11	0.118
E1	1.4	1.6	1.8	0.055	0.063	0.071
L	0.3	0.45	0.6	0.012	0.018	0.024
L1	0.5	0.6	0.7	0.02	0.024	0.028
e	1.9 BSC			0.075 BSC		
e1	0.95 BSC			0.037 BSC		

JEDEC outline: NA

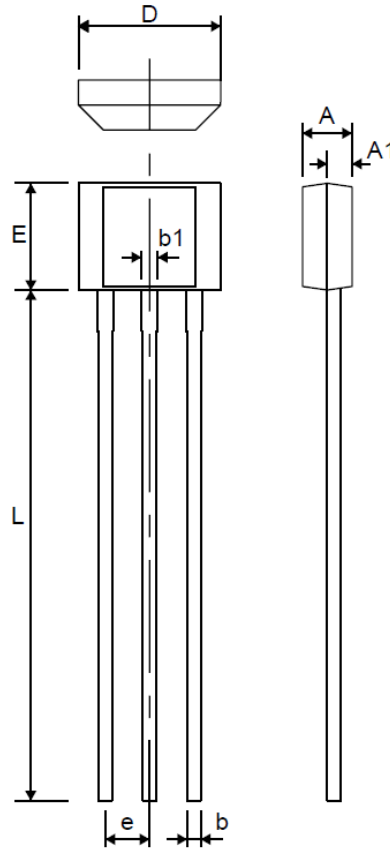
**2. SIP-3L**

Symbol	Dimensions in Millimeters			Dimensions in Inches		
	Min.	Nom.	Max.	Min.	Nom.	Max.
A	1.20	1.48	1.76	0.047	0.058	0.069
A1	0.75 REF.			0.030 REF.		
b	0.33	0.38	0.43	0.013	0.015	0.017
b1	0.40	0.45	0.50	0.016	0.018	0.020
D	3.90	4.10	4.30	0.154	0.161	0.169
e1	1.27 BSC			0.050 BSC		
E	2.80	3.00	3.20	0.110	0.118	0.126
L	13.60	14.60	15.60	0.535	0.575	0.614

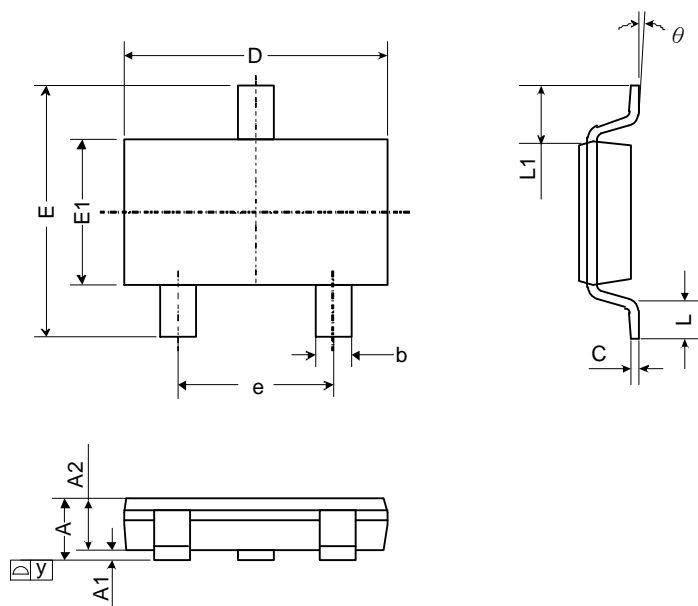
**3. TSOT23-3L**

Symbol	Dimensions in Millimeters			Dimensions in Inches		
	Min.	Nom.	Max.	Min.	Nom.	Max.
A	-	-	1.00	0.030	-	0.039
A1	0.00	-	0.15	0.000	-	0.006
A2	0.70	0.75	0.85	0.028	0.030	0.034
b	0.35	-	0.51	0.014	-	0.020
C	0.10	-	0.25	0.004	-	0.010
D	2.80	2.90	3.00	0.110	0.114	0.118
E	2.60	2.80	3.00	0.102	0.110	0.118
E1	1.50	1.60	1.70	0.059	0.063	0.067
e	1.90 BSC.			0.075 BSC.		
L	0.37	-	-	0.015	-	-
L1	0.60 REF.			0.024 REF.		
L2	0.25 BSC.			0.010 BSC.		
y	-	-	0.10	-	-	0.004
$\theta$	0°	-	8°	0°	-	8°

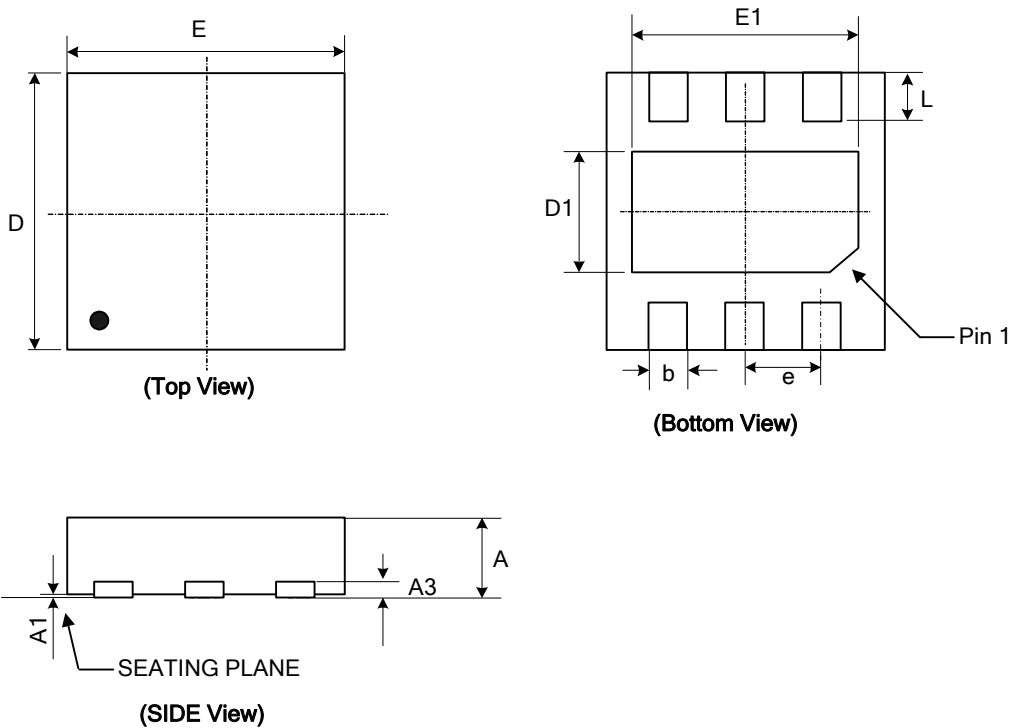

**4. DFN1.6X1.6-6L**

Symbol	Dimensions in Millimeters			Dimensions in Inches		
	Min.	Nom.	Max.	Min.	Nom.	Max.
A	0.4	0.45	0.5	0.016	0.018	0.020
A1	0	0.02	0.05	0.000	0.001	0.002
A3	0.15 REF.			0.006 REF.		
b	0.15	0.2	0.25	0.006	0.008	0.010
D	1.55	1.6	1.65	0.061	0.063	0.065
D1	0.65	0.7	0.75	0.026	0.028	0.030
E	1.55	1.6	1.65	0.061	0.063	0.065
E1	1.25	1.3	1.35	0.049	0.051	0.053
e	0.5 BSC.			0.020 BSC.		
L	0.2	0.25	0.3	0.008	0.010	0.012