

HSF

Recommended P.C.B Layout(Top Side)
(PCB BOARD TOLERANCE±0.05)

NOTES:
 Rated Current: 3.0AMP
 Rated Voltage: 250V AC/DC
 Contact Resistance: 20mΩ max
 Withstand Voltage: 800V AC/DC
 Insulation Resistance: 1000MΩ min
 Operation Temperature: -25℃ to +85℃

Contact Material: Brass
 Contact plating: Au Or Sn Over Ni
 Insulator Material: PA66 Or PA46 UL94V-0

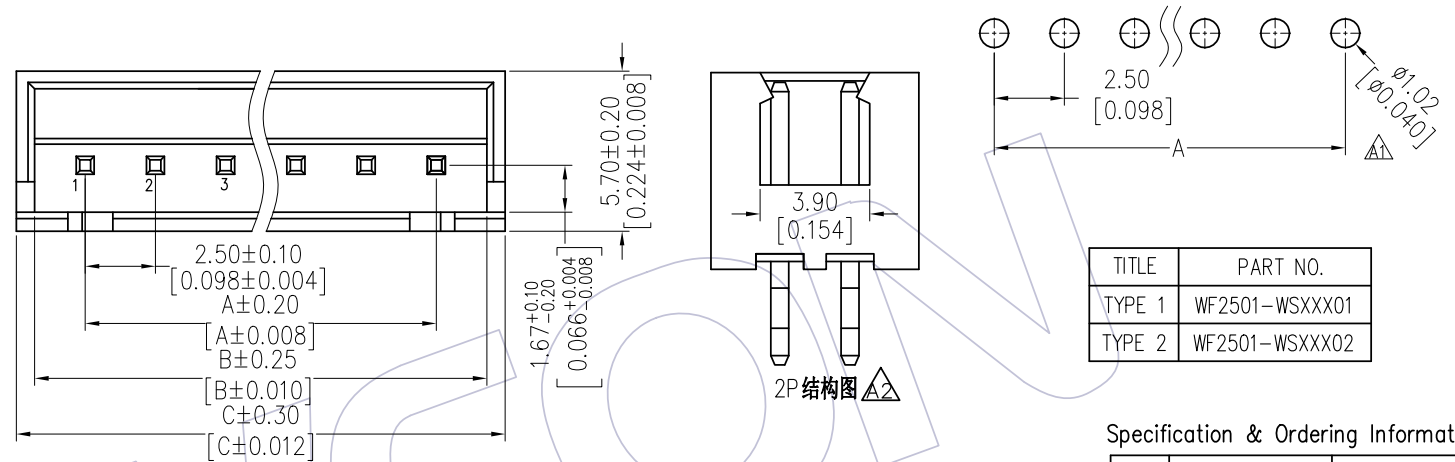

TITLE	PART NO.
TYPE 1	WF2501-WSXXX01
TYPE 2	WF2501-WSXXX02

Ordering Information

WF2501 - WS **XX** **X** **0** **X**

No. of pins: 02P~16P, 20P
 Contact Plating: S0=Gold Flash/Tin, S3=10u"Gold/Tin, S4=15u"Gold/Tin, S5=30u"Gold/Tin, G0=Gold Flash, G3=10u"Gold, G4=15u"Gold, G5=30u"Gold, Blank=Tin
 Color: B=Black, T=Natural, W=White, E=Beige
 Series No.: 1=Type 1, 2=Type 2
 Packing: 0=PE Bag, T=Tube
 H=PA46, Blank=PA66

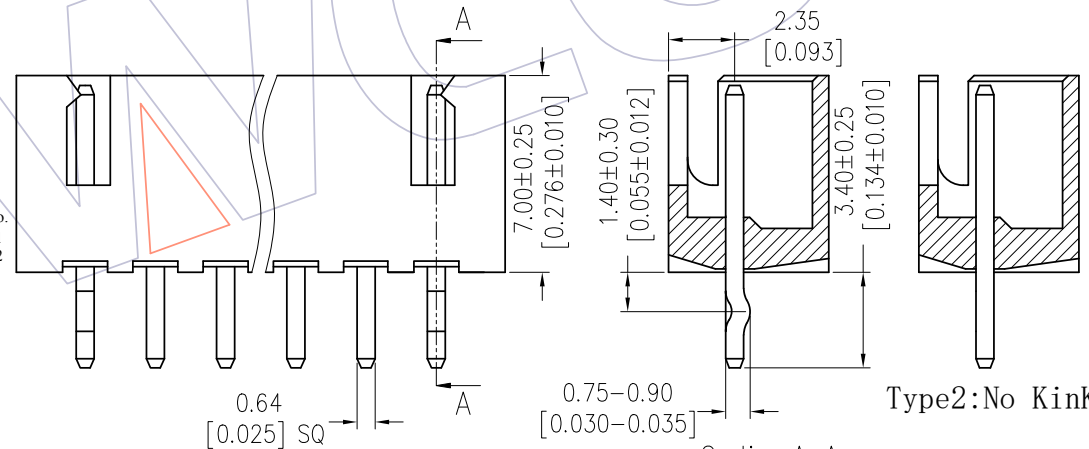

Section A-A
 Type1:Kink
 Type2:No Kink

Specification & Ordering Information:

Circuit	Part No.	Dimension		
		A	B	C
02	WF2501-WS02X0X	2.50	6.1	7.4
03	WF2501-WS03X0X	5.00	8.6	9.9
04	WF2501-WS04X0X	7.50	11.1	12.4
05	WF2501-WS05X0X	10.00	13.6	14.9
06	WF2501-WS06X0X	12.50	16.1	17.4
07	WF2501-WS07X0X	15.00	18.6	19.9
08	WF2501-WS08X0X	17.50	21.1	22.4
09	WF2501-WS09X0X	20.00	23.6	24.9
10	WF2501-WS10X0X	22.50	26.1	27.4
11	WF2501-WS11X0X	25.00	28.6	29.9
12	WF2501-WS12X0X	27.50	31.1	32.4
13	WF2501-WS13X0X	30.00	33.6	34.9
14	WF2501-WS14X0X	32.50	36.1	37.4
15	WF2501-WS15X0X	35.00	38.6	39.9
16	WF2501-WS16X0X	37.50	41.1	42.4
20	WF2501-WS20X0X	47.50	51.1	52.4

REV	DATE	MODIFICATION DESCRIPTION	CHANGE	OPERATION	DRAW	DATE	SCALE	FIT	PART NO.
A2	2017/02/13	Add 2P DRAW	△	x.xx ±0.40	Ding	2017/02/13	UNIT	mm	WF2501-WSXXX0X
A1	2013/10/24	MODIFY THE PCB HOLE DIM	—	x.xx ±0.25	CHECK	DATE	SIZE	A4	TITLE:
AO	2012/09/05	NEW	—	x.xxx ±0.15	APPROVE	DATE	SHEET	1/1	"J"TYPE 2.50 WAFER 180° DIP
				Angle ± 3°			PROJ.	Customer NO.	
				DIM TOL					

WCON

Http: www.wcon.com

WCON-Dongguan Tel: +86 769 85358920 Fax: +86 769 85358915 E-mail: sales@wcon.com
 WCON-Kunshan Tel: +86 512 57468408 Fax: +86 512 57468468 E-mail: sales@wcon.com