

N-CHANNEL POWER MOSFET MEM12N65

General Description

- Switching regulator application.
- High voltage and high speed.
- Switching application.

Features

- 650V, 12A
- $R_{DS(ON)}=0.64\Omega@V_{GS}=10V$
- Low CRSS
- Fast switching
- Package : TO-220F

Pin Configuration

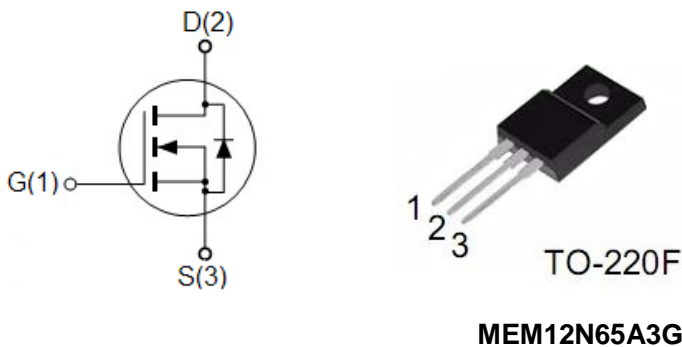

Maximum Ratings (Ta=25°C)

Parameter	Symbol	Ratings	Unit
Drain-Source Voltage	V_{DSS}	650V	V
Gate-Source Voltage	V_{GSS}	± 30	V
Drain Current	I_D	$T_A=25^\circ C$	12
		$T_A=100^\circ C$	9
Pulsed Drain Current ^{1,2}	I_{DM}	48	A
Total Power Dissipation	P_d	51	W
Operating Junction Temperature Range	T_J	-40~150	°C
Storage Temperature Range	T_{stg}	-55~150	°C

Thermal Characteristics

Parameter	Symbol	TYP.	MAX.	Unit
Thermal Resistance, Junction-to-Case	$R_{\theta JC}$	2.7	3	°C/W

Electrical Characteristics

Parameter	Symbol	Test Condition	Min	Type	Max	Unit
Static Characteristics						
Drain-Source Breakdown Voltage	$V_{(BR)DSS}$	$V_{GS}=0V, I_D=250\mu A$	650	-	-	V
Gate Threshold Voltage	$V_{GS(th)}$	$V_{DS}=V_{GS}, I_D=250\mu A$	2.0	-	4.0	V
Gate-Body Leakage	I_{GSS}	$V_{DS}=0V, V_{GS}=30V$	-	-	100	nA
		$V_{DS}=0V, V_{GS}=-30V$	-	-	-100	nA
Zero Gate Voltage Drain Current	I_{DSS}	$V_{DS}=650V, V_{GS}=0V$	-	0.2	1	μA
Static Drain-Source On-Resistance	$R_{DS(ON)}$	$V_{GS}=10V, I_D=3.5A$	-	0.64	0.8	Ω
Forward Transconductance	g_{FS}	$V_{DS}=15V, I_D=3A$	-	2	10	S
Drain-Source Diode Forward Continuous Current	I_S	$V_{GS}=0V$	-	-	12	A
Source-drain (diode forward) voltage	V_{SD}	$V_{GS}=0V, I_S=12A$	-	-	1.4	V
Dynamic Characteristics						
Input Capacitance	C_{iss}	$V_{DS}=25V,$ $V_{GS}=0V,$ $f=1MHz(\text{Note1,2})$	-	1476	-	pF
Output Capacitance	C_{oss}		-	152	-	
Reverse Transfer Capacitance	C_{rss}		-	4.5	-	
Switching Characteristics						
Turn-On Delay Time	$t_{d(on)}$	$V_{DD}=325V,$ $R_G=25\Omega$ $V_{GS}=10V,$ $I_D=12A(\text{Note2})$	-	37	-	ns
Rise Time	t_r		-	61	-	
Turn-Off Delay Time	$t_{d(off)}$		-	80	-	
Fall-Time	t_f		-	46	-	
Total Gate Charge	Q_g	$V_{DS}=520V,$ $V_{GS}=10V,$ $I_D=12A(\text{Note1,2})$	-	24.15	-	nC
Gate-Source Charge	Q_{gs}		-	7.86	-	
Gate-Drain Charge	Q_{gd}		-	7.47	-	

Note: 1、Not influenced by junction temperature.

2、Pulse width <300 μs , duty cycle <2%.

Typical performance characteristics

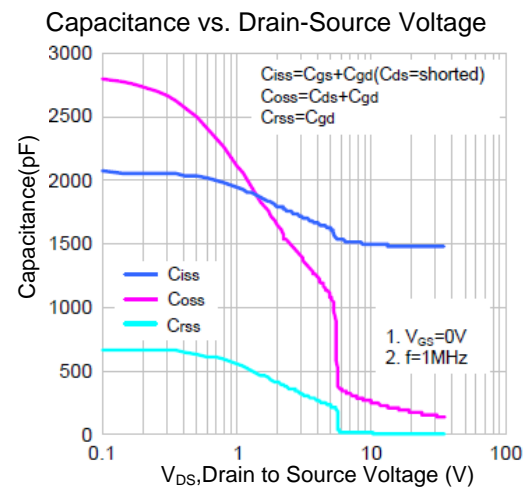
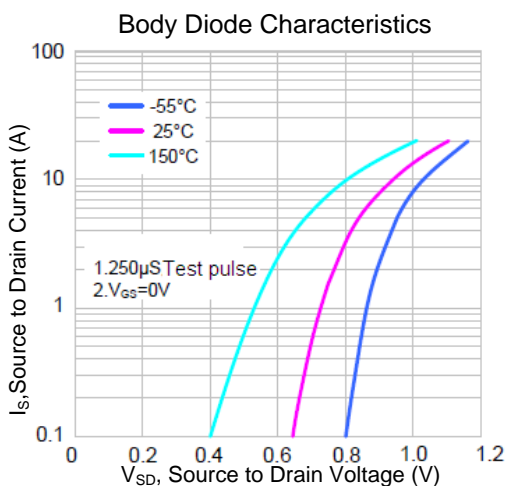
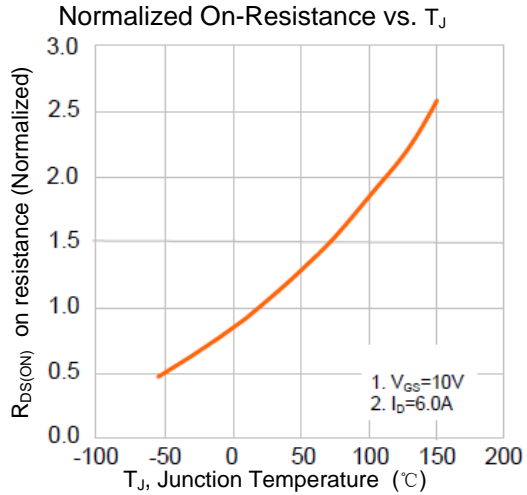
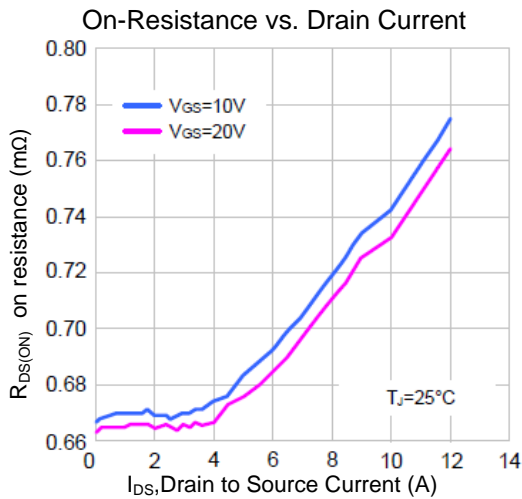
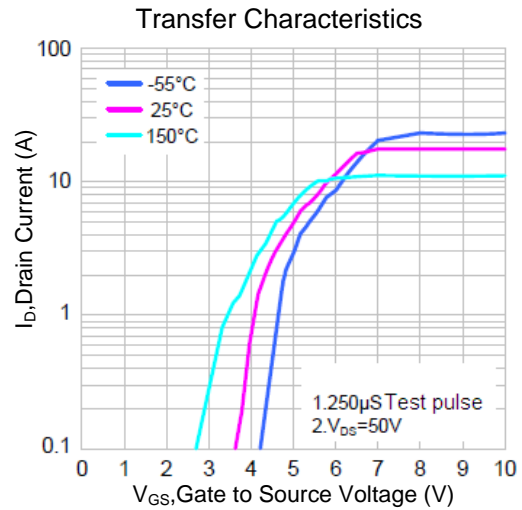
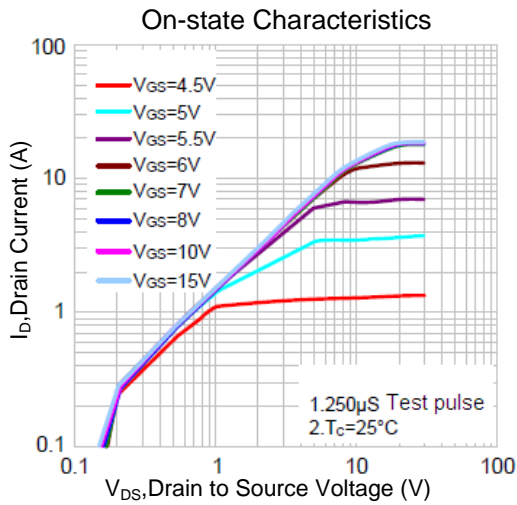

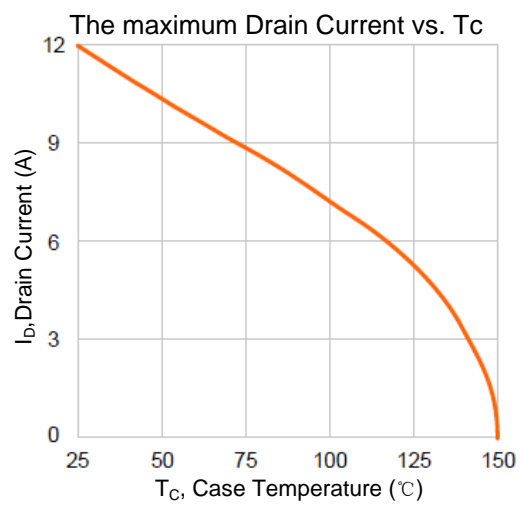
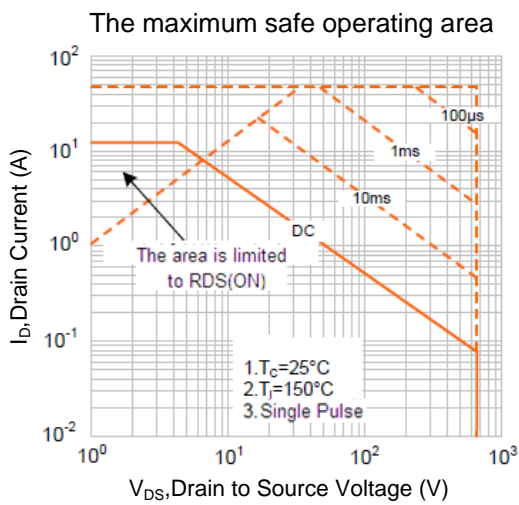
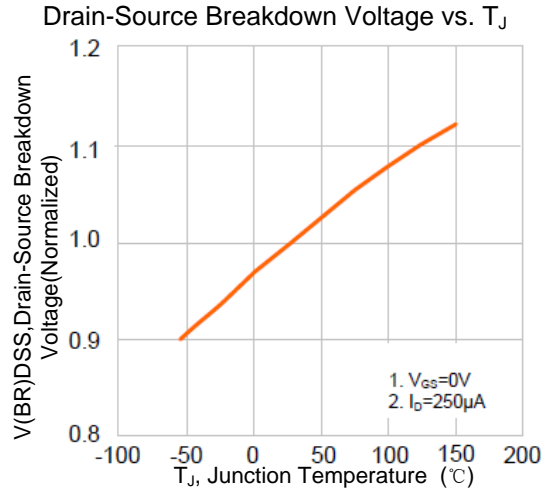
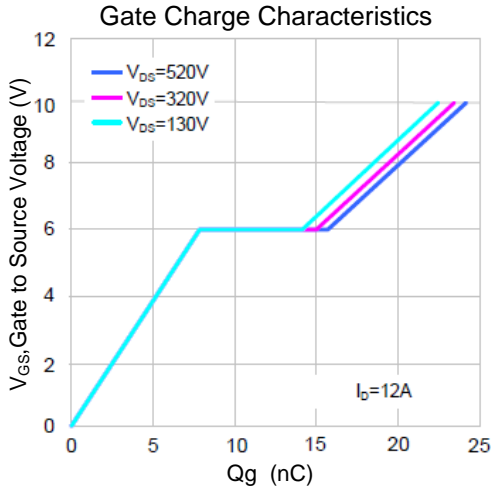

Typical Circuit

Gate Charge Testing circuit with Waveform

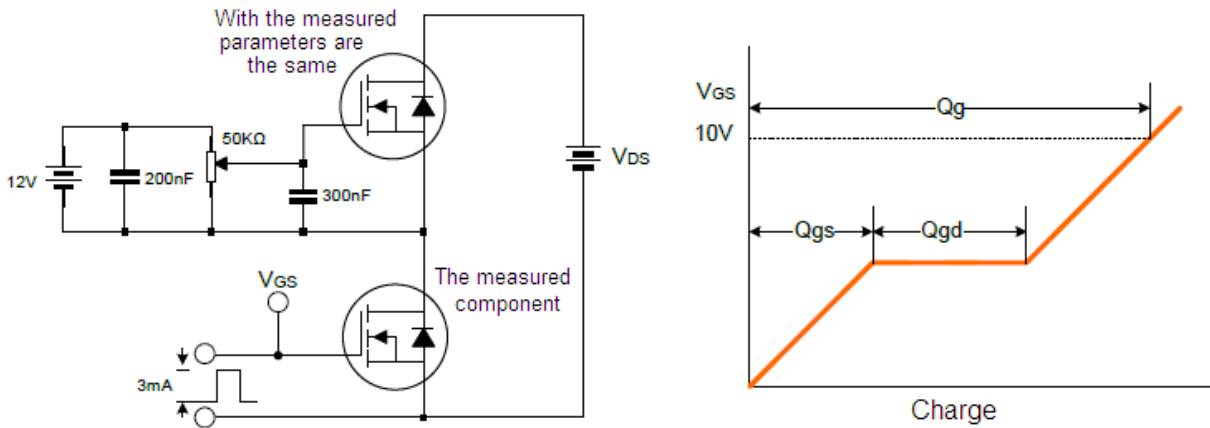

Switching test circuit with Waveform

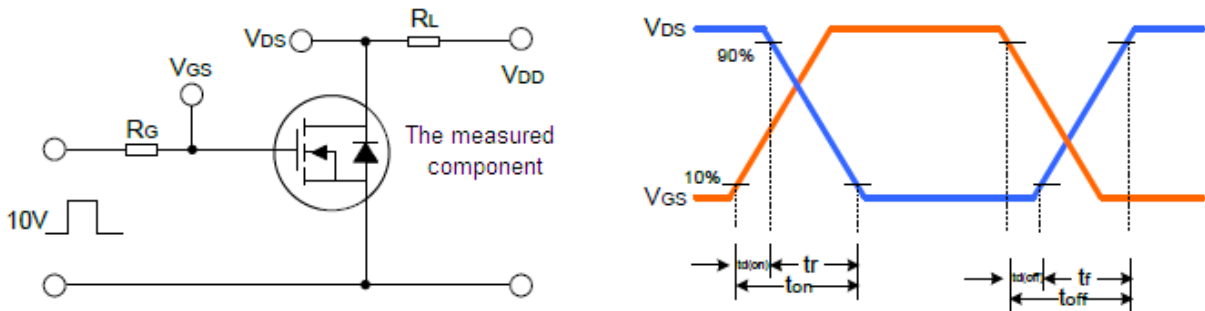

Eas Test circuit and Waveform

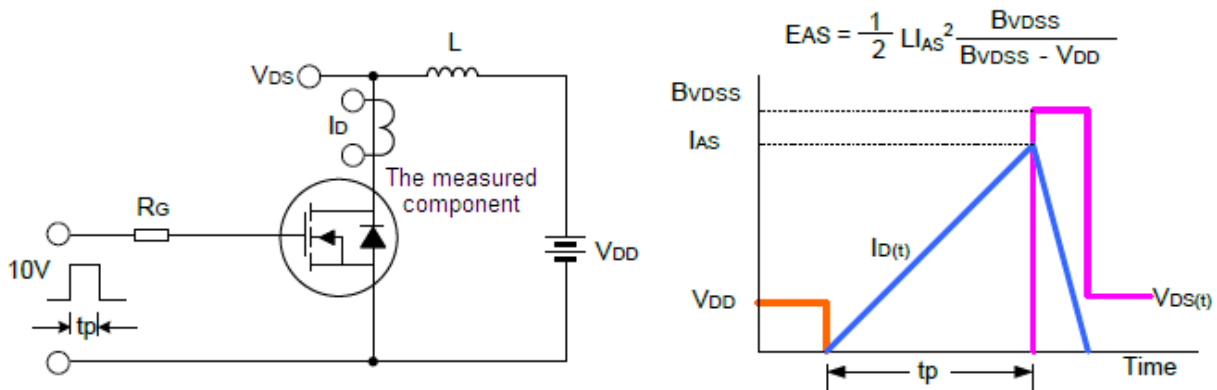

Package Information

- Package Type: TO-220F

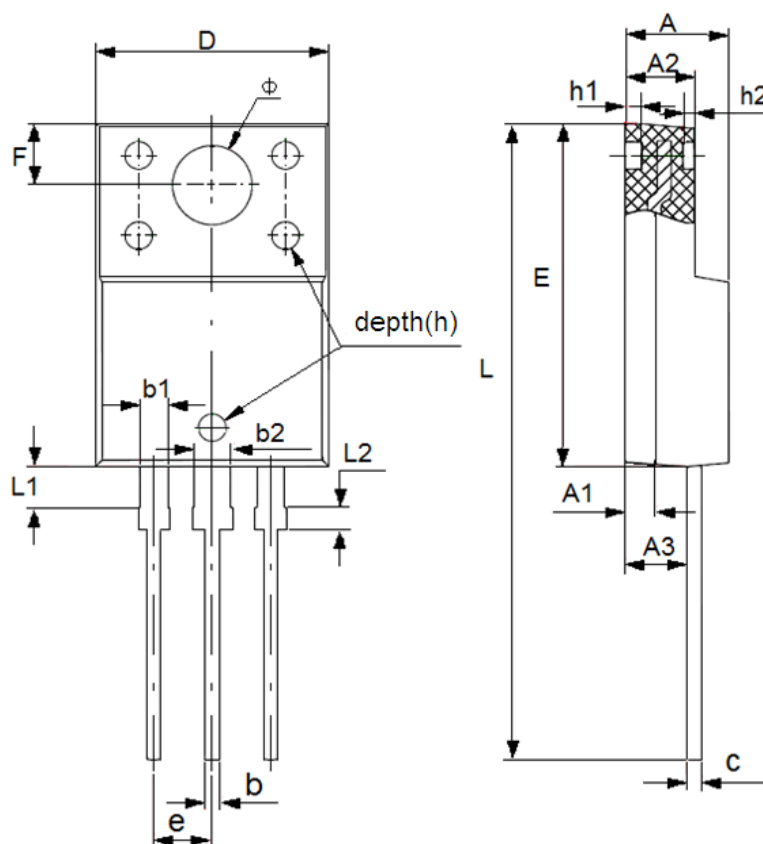

DIM	Millimeters		Inches	
	Min	Max	Min	Max
A	4.3	4.83	0.1693	0.1902
A1	1.3(TYP)		0.0512(TYP)	
A2	2.45	3.2	0.0965	0.126
A3	2.5	2.9	0.0984	0.1142
b	0.5	0.75	0.0197	0.0295
b1	1.1	1.35	0.0433	0.0531
b2	1.5	1.75	0.0591	0.0689
c	0.5(TYP)		0.0197(TYP)	
D	9.96	10.4	0.3921	0.4094
E	14.8	16.1	0.5827	0.6339
e	2.54(TYP)		0.1(TYP)	
F	2.7(TYP)		0.1063(TYP)	
Φ	3.45(TYP)		0.1358(TYP)	
h	0.15(TYP)		0.0059(TYP)	
h1	0.8(TYP)		0.0315(TYP)	
h2	0.5(TYP)		0.0197(TYP)	
L	28	28.8	1.1024	1.1339
L1	1.7	1.9	0.067	0.0748
L2	0.9	1.1	0.0354	0.0433

- The contents of this document will be updated with the product's improvement without prior notice. Please consult our sales staff before using this document to ensure that you are using the latest version.
- The application circuit examples described in this document are only used to indicate the representative use of the product and do not guarantee the design of mass production.
- Please use this product within the limits stated in this document. We will not be responsible for any damage caused by improper use.
- The products described in this document are not allowed to be used in equipment or devices that affect the human body without the written permission of our company, including but not limited to: health equipment, medical equipment, disaster prevention equipment, fuel control equipment, automobile equipment, aviation equipment and vehicle equipment.
- Although our company has always been committed to improving product quality and reliability, semiconductor products have a certain probability of malfunction or wrong work. To prevent personal injury or property damage caused by such accidents, please pay full attention to safety design, for example: Alternate design, fire protection design, and prevention of wrong action design.
- When exporting this product or this document overseas, you should abide by applicable import and export control laws.
- Copying or reprinting part or all of this document in any form without the permission of our company is strictly prohibited.