

N-Channel Enhancement Mode MOSFET

TDM2618

DESCRIPTION

The TDM2618 uses advanced trench technology to provide excellent RDS(ON) and low gate charge. This device is suitable for use as a load switch or in PWM applications.

GENERAL FEATURES

- RDS(ON) < 9mΩ @ VGS=10V
RDS(ON) < 13.7mΩ @ VGS=4.5V
- High Power and current handling capability
- Lead free product is available
- Surface Mount Package

Application

- Secondary Side Synchronous Rectification.
- DC-DC Converter.
- Motor Control.
- Load Switching.

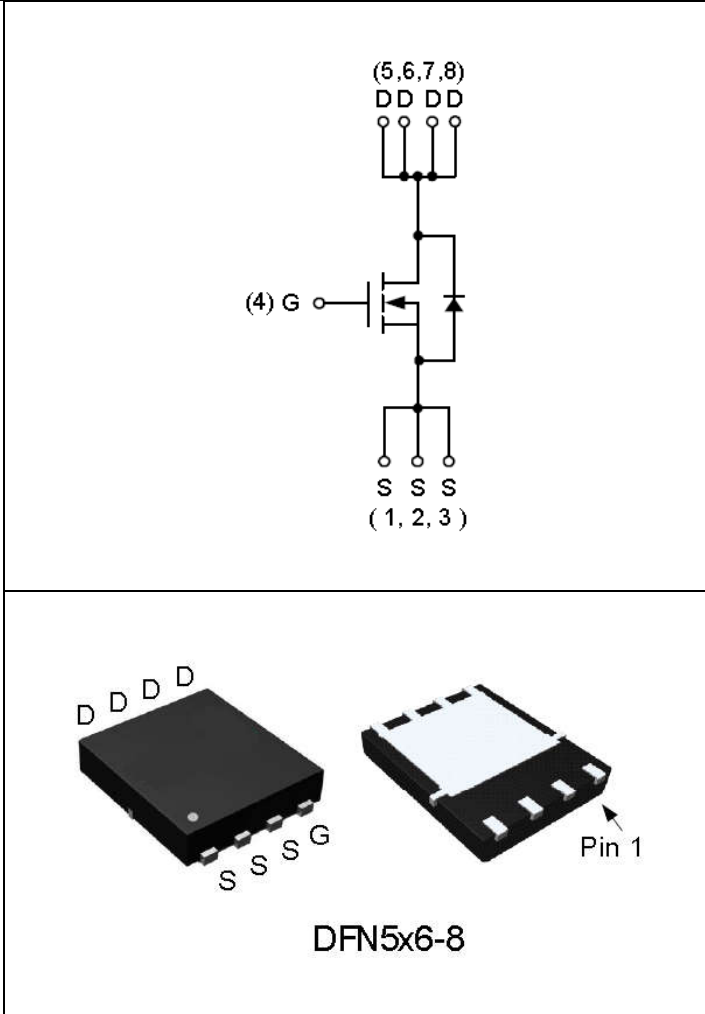

ABSOLUTE MAXIMUM RATINGS(TA=25°C unless otherwise noted)

Parameter	Symbol	Limit	Unit
Drain-Source Voltage	V _{DS}	60	V
Gate-Source Voltage	V _{GS}	±20	V
Diode Continuous Forward Current	I _S (T _C =25°C)	23	A
Drain Current @ Continuous	I _D (T _C =25°C)	47	A
	I _D (T _C =100°C)	30	A
Drain Current @ Current-Pulsed (Note 1)	I _{DM} (T _C =25°C)	180	A
Maximum Power Dissipation	P _D (T _C =25°C)	36.7	W
	P _D (T _C =100°C)	14.7	W
Drain Current @ Continuous	I _D (T _A =25°C)	11.3	A
	I _D (T _A =70°C)	9	A
Maximum Power Dissipation	P _D (T _A =25°C)	2.08	W
	P _D (T _A =70°C)	1.33	W
Thermal Resistance,Junction-to-Case	R _{θJC} (Steady State)	3.4	°C/W
Thermal Resistance,Junction-to-Ambient (Note 2)	R _{θJA} (Steady State)	60	°C/W
Avalanche Current, Single pulse(Note 3)	I _{AS} (L=0.5mH)	16	A
Avalanche Energy, Single pulse(Note 3)	E _{AS} (L=0.5mH)	64	mJ

N-Channel Enhancement Mode MOSFET
TDM2618

Maximum Operating Junction Temperature	T _J	150	°C
Storage Temperature Range	T _{STG}	-55 To 150	°C

ELECTRICAL CHARACTERISTICS (T_A=25°C unless otherwise noted)

Parameter	Symbol	Condition	Min	Typ	Max	Unit
OFF CHARACTERISTICS						
Drain-Source Breakdown Voltage	BV _{DSS}	V _{GS} =0V, I _D =250μA	60	-	-	V
Zero Gate Voltage Drain Current	I _{DSS}	V _{DS} =48V, V _{GS} =0V	-	-	1	μA
Gate-Body Leakage Current	I _{GSS}	V _{GS} =±20V, V _{DS} =0V	-	-	±100	nA
ON CHARACTERISTICS (Note4)						
Gate Threshold Voltage	V _{GS(th)}	V _{DS} =V _{GS} , I _D =250μA	1	2	3	V
Drain-Source On-State Resistance	R _{DS(ON)}	V _{GS} =10V, I _D =20A	-	7.5	9	mΩ
		V _{GS} =4.5V, I _D =15A	-	10.5	13.7	mΩ
DYNAMIC CHARACTERISTICS (Note 5)						
Gate Resistance	R _G	V _{DS} =0V, V _{GS} =0V, F=1.0MHz	-	1.5	-	Ω
Input Capacitance	C _{iss}	V _{DS} =30V, V _{GS} =0V, F=1.0MHz	-	1225	1600	PF
Output Capacitance	C _{oss}		-	235	-	PF
Reverse Transfer Capacitance	C _{rss}		-	30	-	PF
SWITCHING CHARACTERISTICS (Note 5)						
Turn-on Delay Time	t _{d(on)}	V _{DS} =30V, R _L =30Ω, V _{GEN} =10V, R _G =6Ω I _D =1A	-	14	26	nS
Turn-on Rise Time	t _r		-	8	15	nS
Turn-Off Delay Time	t _{d(off)}		-	29	51	nS
Turn-Off Fall Time	t _f		-	26	47	nS
Total Gate Charge	Q _g	V _{DS} =30V, I _D =20A, V _{GS} =10V	-	20.6	29	nC
Gate-Source Charge	Q _{gs}		-	4.3	-	nC
Gate-Drain Charge	Q _{gd}		-	3.7	-	nC
Body Diode Reverse Recovery Time	T _{rr}	I _{SD} =20A, di/dt=100A/μs	-	25	-	nS
Body Diode Reverse Recovery Charge	Q _{rr}		-	17	-	nC
DRAIN-SOURCE DIODE CHARACTERISTICS						
Diode Forward Voltage (Note 4)	V _{SD}	V _{GS} =0V, I _S =2A	-	0.8	1.3	V

NOTES:

1. Pulse width limited by max. junction temperature.
2. Surface Mounted on 1in² pad area.
3. UIS tested and pulse width limited by maximum junction temperature 150°C (initial temperature T_J=25°C).
4. Pulse Test: Pulse Width ≤ 300μs, Duty Cycle ≤ 2%.
5. Guaranteed by design, not subject to production testing

Typical Operating Characteristics

Power Dissipation

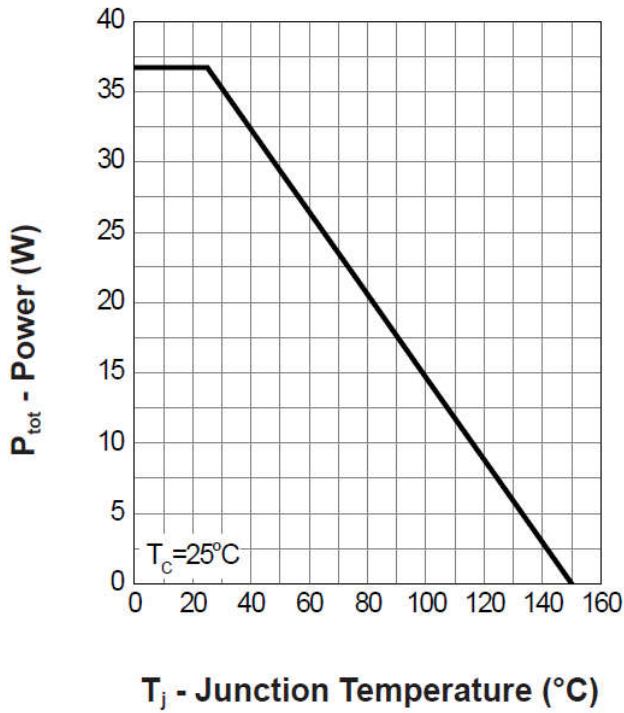

Drain Current

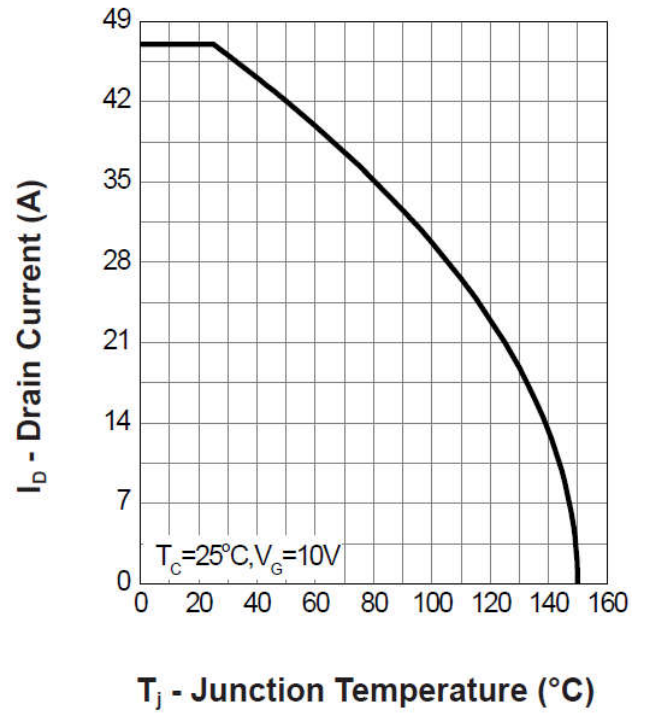

Safe Operation Area

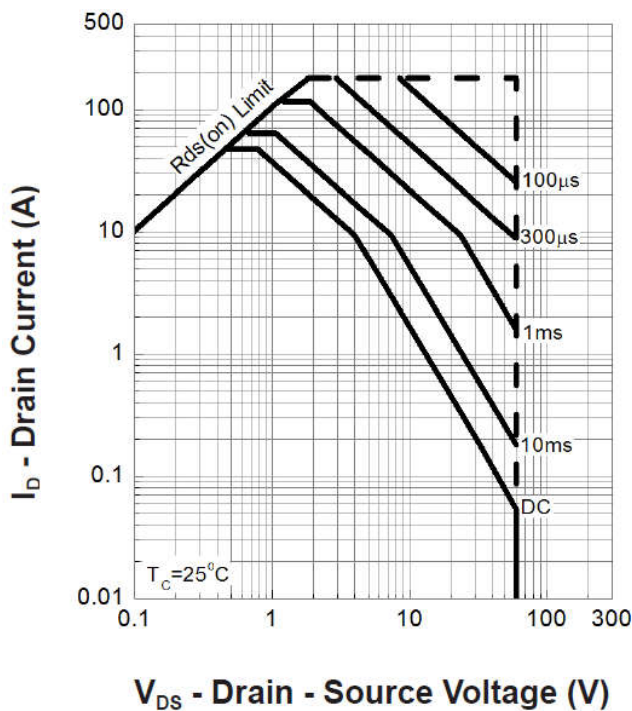

Thermal Transient Impedance

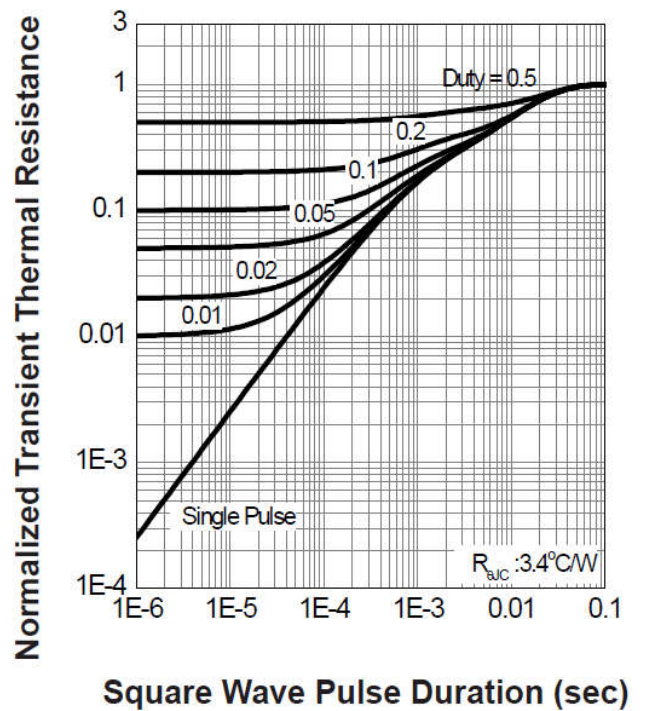

Typical Operating Characteristics(Cont.)

Output Characteristics

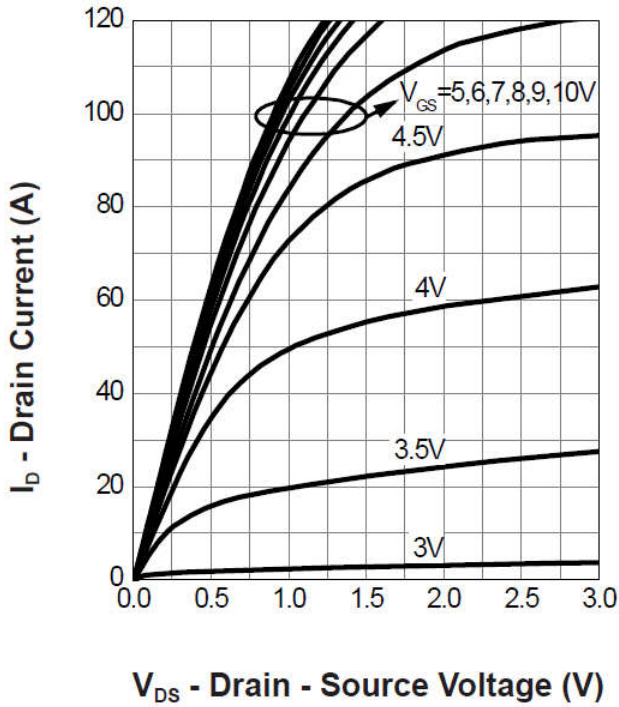

Drain-Source On Resistance

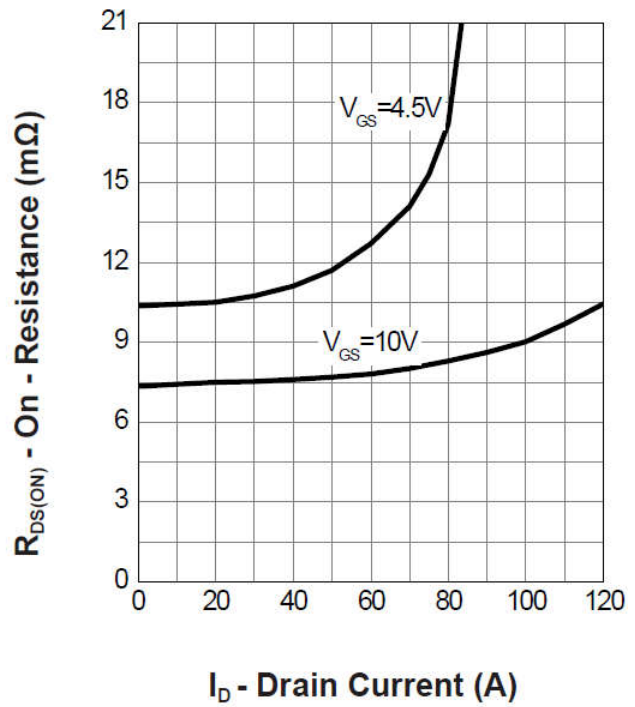

Gate-Source On Resistance

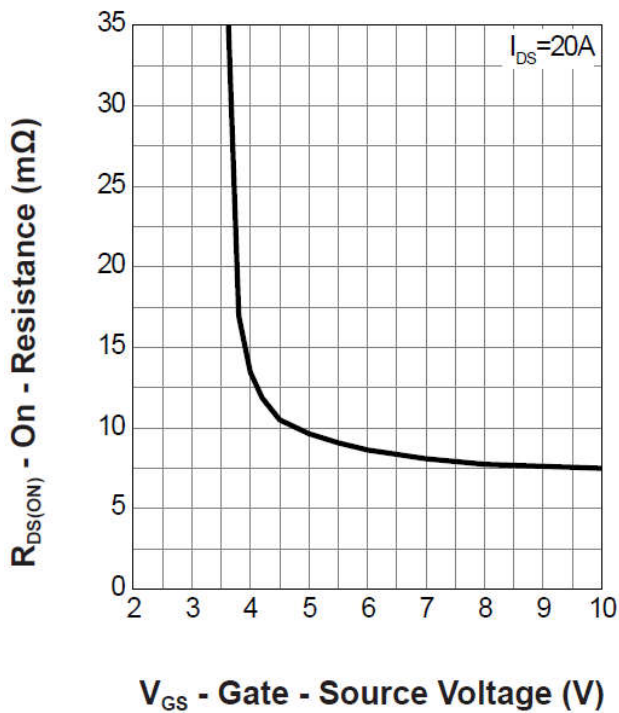

Gate Threshold Voltage

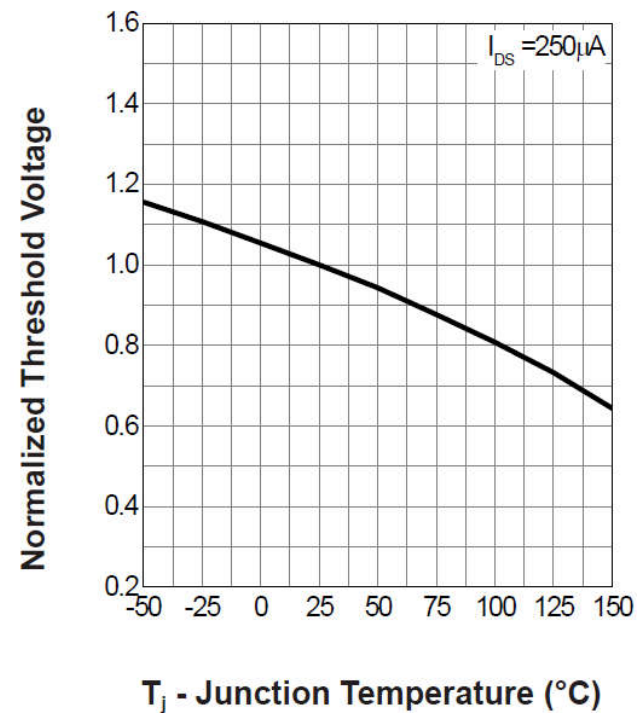

Typical Operating Characteristics (Cont.)

Drain-Source On Resistance

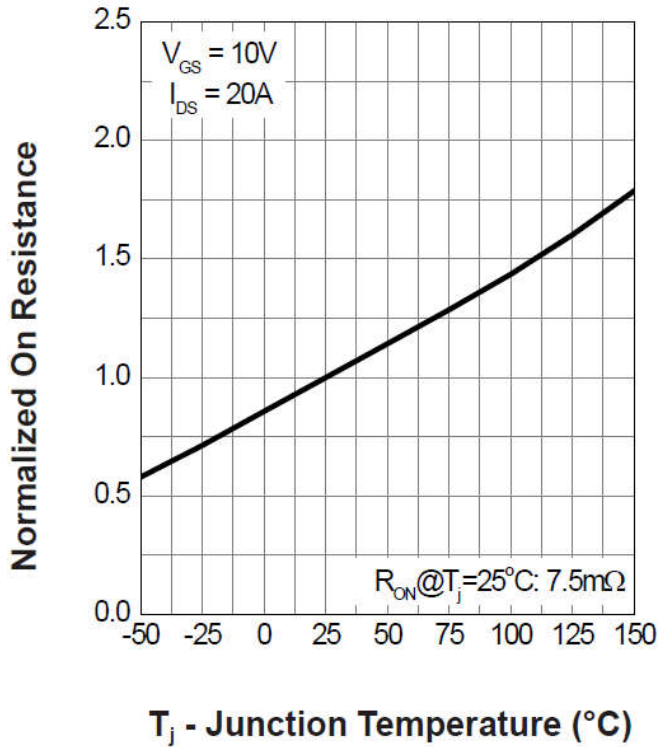

Source-Drain Diode Forward

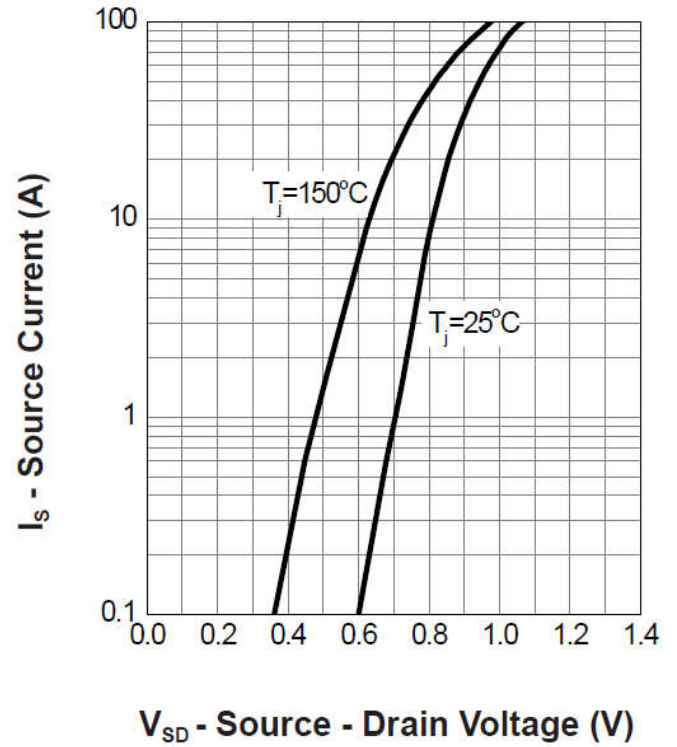

T_j - Junction Temperature ($^{\circ}\text{C}$)
Capacitance

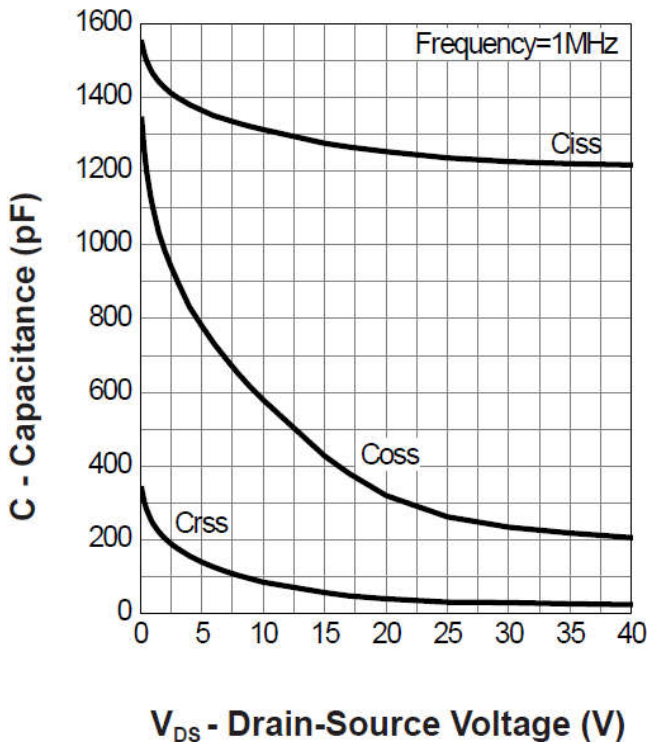

V_{GS} - Gate-source Voltage (V)
Gate Charge

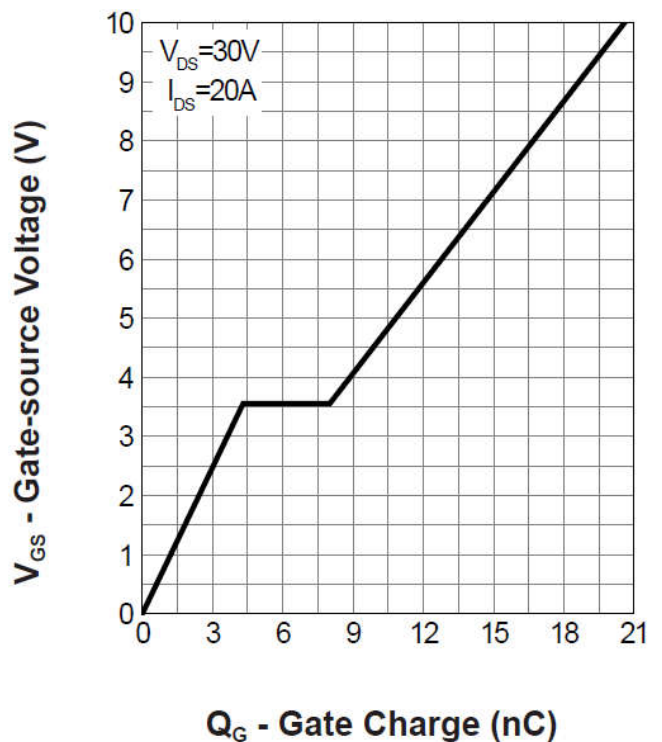

Typical Operating Characteristics (Cont.)

Transfer Characteristics

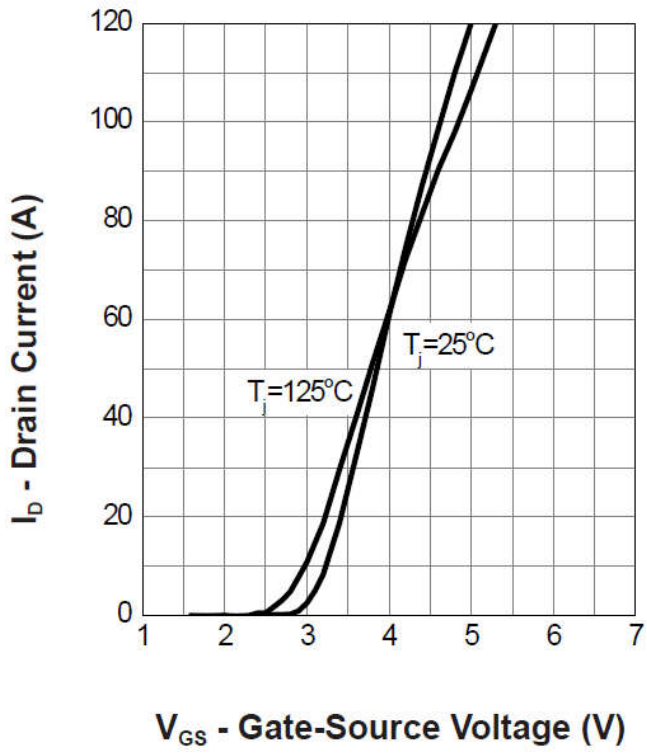

Package Information

DFN5X6-8 Package

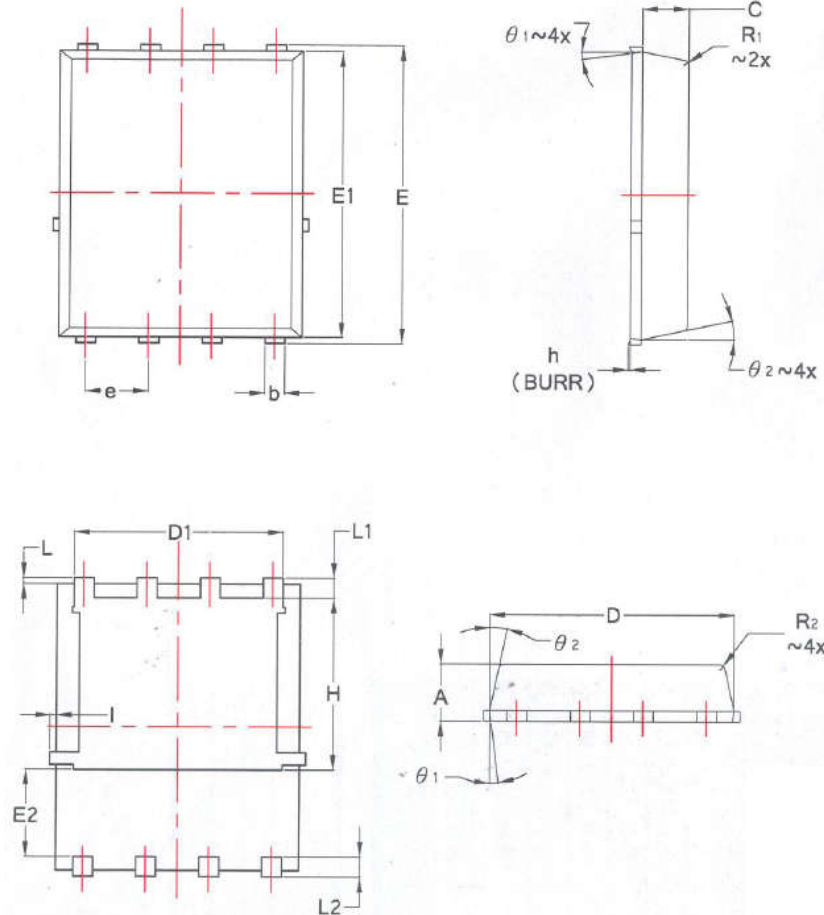

SYMBOL	COMMON			
	MM		INCH	
	MIN.	MAX.	MIN.	MAX.
A	1.03	1.17	0.0406	0.0461
b	0.35	0.46	0.0138	0.0181
C	0.84	0.95	0.0331	0.0374
D	4.83	4.97	0.1902	0.1957
D1	4.14	4.28	0.1630	0.1685
E	6.03	6.13	0.2374	0.2413
E1	5.68	5.82	0.2236	0.2291
E2	1.65	—	0.0650	—
e	1.27 BSC		0.05 BSC	
L	0.125	0.195	0.0049	0.0077
L1	0.40	0.48	0.0157	0.0189
L2	0.40	0.48	0.0157	0.0189
H	3.55	3.65	0.1398	0.1437
I	—	0.16	—	0.0063
R1	0.1		0.004	
R2	0.1		0.004	
theta1	7°		7°	
theta2	12°		12°	
h	0.08MAX		0.0031MAX	

- NOTES:
 1. ALL DIMENSIONS ARE IN MILLIMETERS
 2. MOLD FLASH PROTRUSION OR GATE BURRS SHALL NOT EXCEED 0.127mm PER END

Design Notes