

环保物料

TEL: 0769-82001899

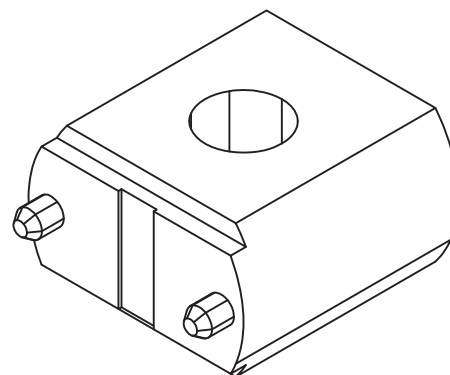
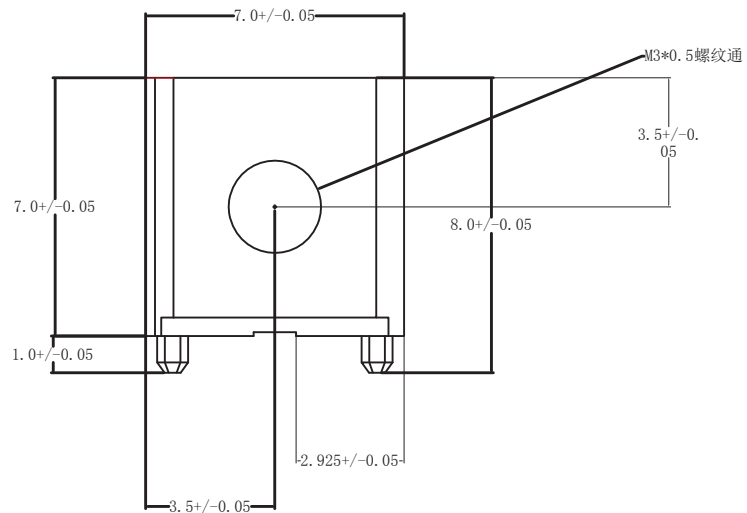

Properties:

Material	Brass
Surface	Tin
Solder Cream Thickness	120 μm
Tightening Torque	0.4 Nm
Operating Temperature	-55 °C up to +150 °C

Electrical Properties:

Properties	Test conditions		Value	Unit	Tol.
Rated Current	@ 20 °C	I <sub>R</sub>	50	A	max.

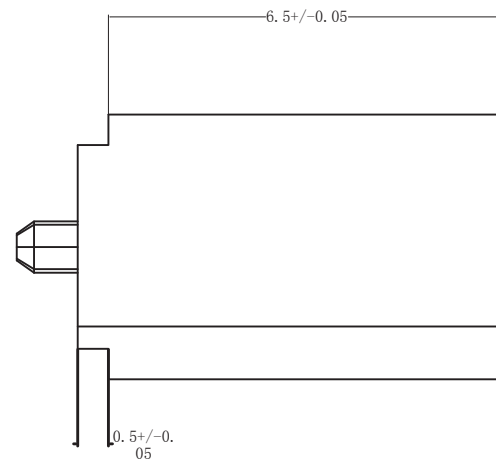
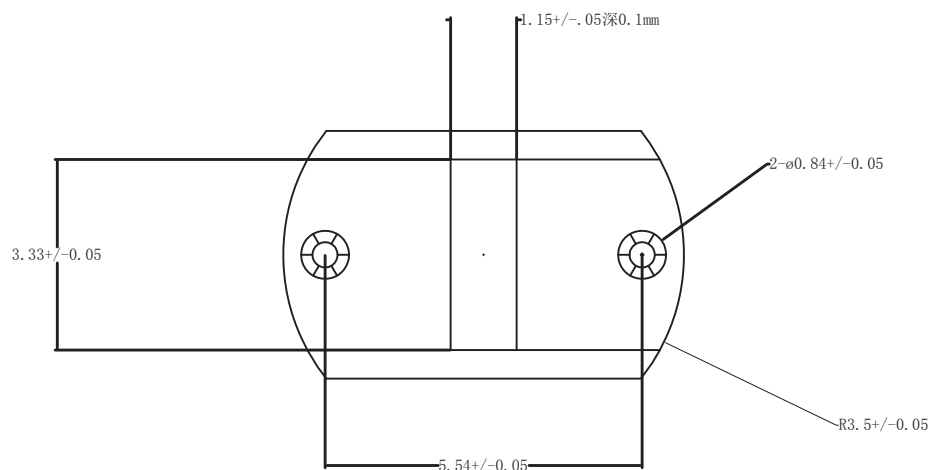

Packaging Properties:

Packaging	Tape and Reel
Packaging Unit (Qty.)	1000

TOLERANCE UNLESS OTHERWISE

X.	±0.30	X°	±5°
.X	±0.20	.X°	±2°
.XX	±0.08	.XX°	±1°
.XXX	±0.03	.XXX°	±0.5°

DRAWN	CK tan
CHKD	
APPD	
VIEW	

**XFCN** 兴飞连接器有限公司  
XFCN CONNECTORS CO.,LTD.

PRODUCT NAME PCB Soldering Terminal

PART. NO. TM374663

SHEET	1/1
DATE	2020.04.12
UNITS	mm
SCALE	1:1
DWG. NO.	009

AO

VER

MODIFICATION

DRAW

DATE

1 2 3 4 5 6 7 8 9 10