

修 订	标 记	修 改 描 要	签 名	日 期
REV NO		REVISON DESCRIPTION	SIGNATURE	DATE
		NEW DRG		2016-03-12

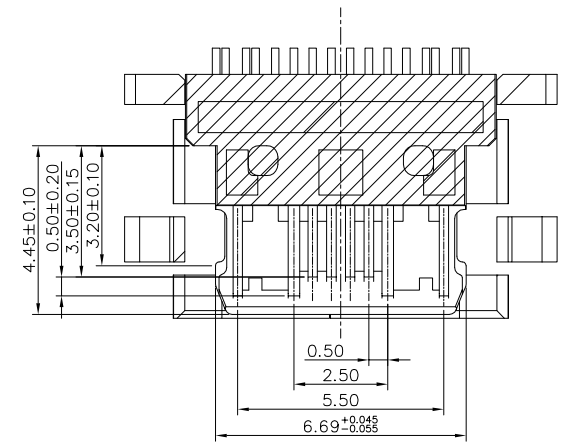

SECTION B-B
SCALE 1:1

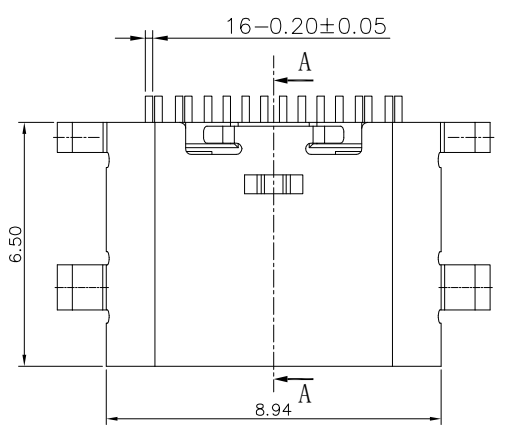
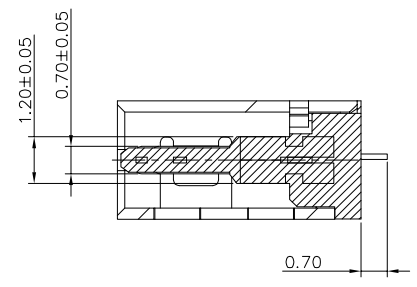
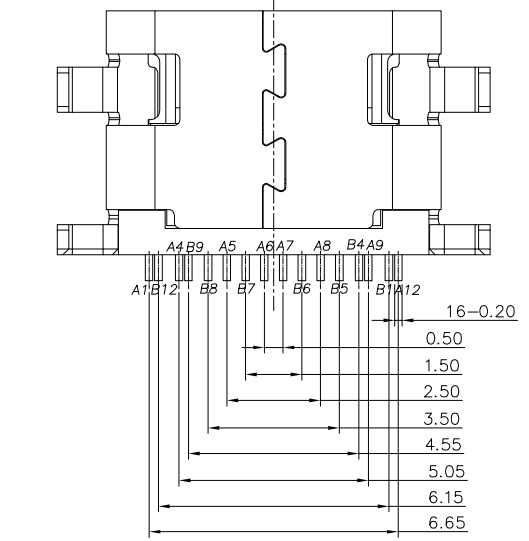
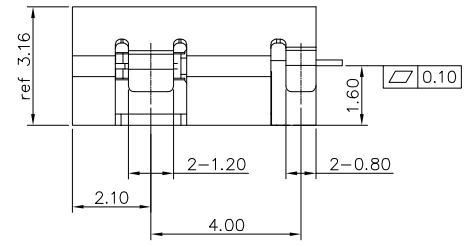
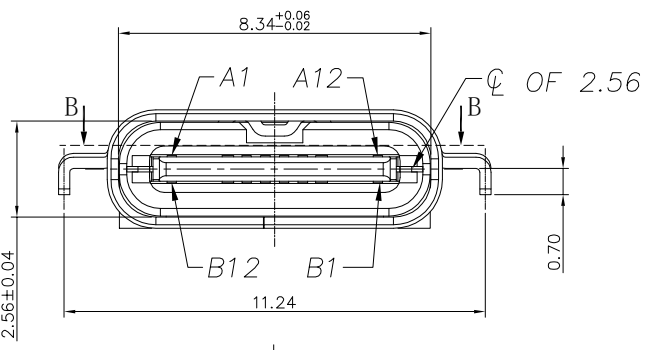

SECTION B-B
SCALE 1:1

NOTE:

- MATERIAL SPECIFICATION:
 - HOUSING: HIGH TEMPERATURE RESISTANT PLASTIC, UL94 V-0.
 - CONTACTS: COPPER ALLOY
 - MID PLATE: STAINLESS STEEL
- PLATING SPECIFICATION:
 - CONTACTS:
 - Ni 50u" MIN. UNDER PLATED OVER ALL.
 - Au PLATED ON THE FUNCTIONAL AREA OF CONTACT. (GOLD PLATING THICKNESS FOLLOW THE P/N)
 - GOLD FLASH PLATING ON SOLDER AREA
 - FRONT SHELL:
 - Ni 30u" MIN. UNDER PLATED OVER ALL.
- MECHANICAL PERFORMANCE,
 - INSERTION FORCE: 0.5~2.0kgf.
 - REMOVAL FORCE: 0.8kgf~2.0kgf.
 - DURABILITY: 10000 CYCLES.
- ELECTRICAL PERFORMANCE,
 - CURRENT RATING: 5A
VOLTAGE RATING: 20V
 - INSULATION RESISTANCE: 100MΩ MIN
 - DIELECTRIC WITHSTAND VOLTAGE, AC 100V FOR 1 MINUTE.
 - LOW CONTACT RESISTANCE: INITIAL 40MΩ
AFTER 50MΩ
- ENVIRONMENTAL PERFORMANCE:
 - OPERATING TEMPERATURE: -30°C~+80°C.
- IR REFLOW:
 - THE PEAK TEMPERATURE ON THE BOARD SHALL BE MAINTAINED FOR 10 SECONDS AT 260°C.



深圳市华德共创科技有限公司
Shenzhen Huade co-create Technology Co., LTD
电话: 0755-23304126 传真: 0755-29940187

-TOLERANCES- UNLESS OTHERWISE SPECIFIED 公差参数表				TITLE: USB 3.1 TYPE C 16PIN 沉板1.6 产品名称: SMT单排母座L=6.5			
X.X ±0.30	X.X* ±3°	APPD: 核准:		PART NO: 产品编号: TYPE C-DB-113PWB			
X.XX ±0.20	X.XX* ±2°	CHECK: 校对: 王建业		DATE	SCALE	UNIT	CODE NUMBER
X.XXX ±0.10	X.XXX* ±1°	DRAW: 绘图: 黄艳兰		2016-03-12	1:1	mm	A001

修订 REV NO	标记 MARK	修改摘要 REVISION DESCRIPTION	签名 SIGNATURE	日期 DATE
		NEW DWG		2016-03-12

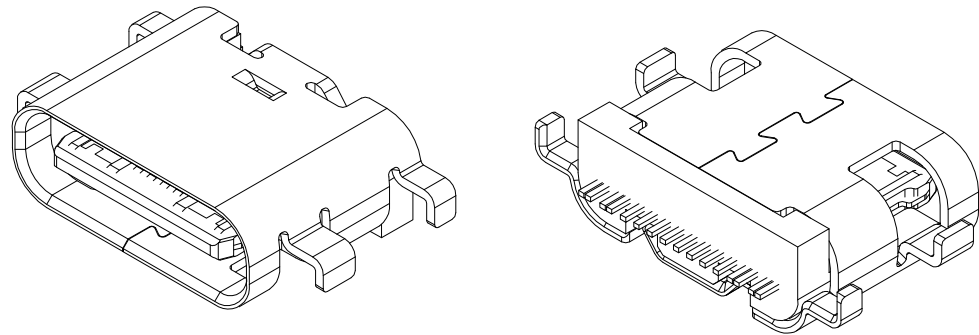

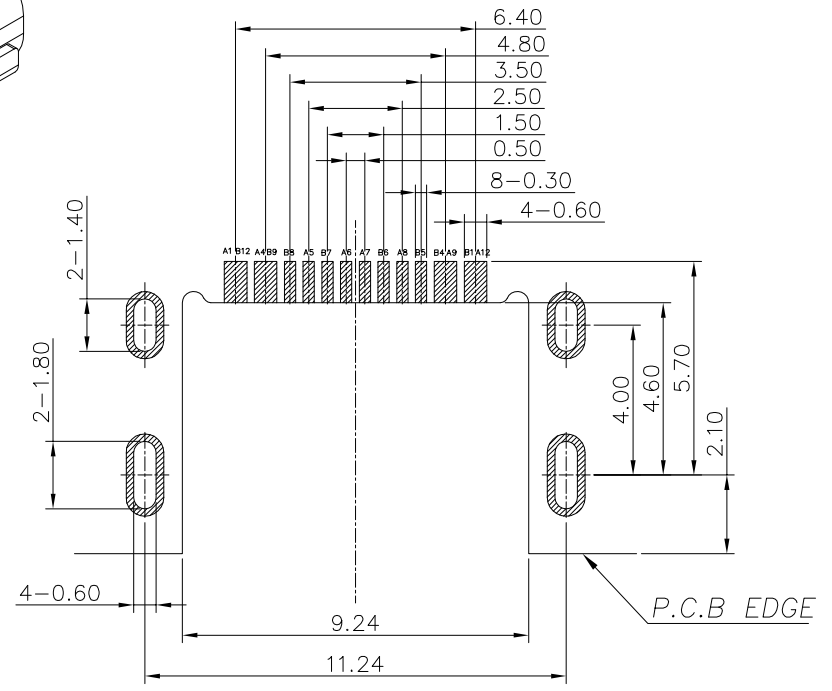

USB TYPE-C PIN ASSIGNMENTS

PIN NUMBER	SIGNAL NAME	PIN NUMBER	SIGNAL NAME
A1	GND	B12	GND
A4	VBUS	B9	VBUS
A5	CC1	B8	SBU2
A6	Dp1	B7	Dn2
A7	Dn1	B6	Dp2
A8	SBU1	B5	CC2
A9	VBUS	B4	VBUS
A12	GND	B1	GND



RECOMMEND P.C.B LAYOUT(COMPONENT SIDE)
TOLERANCE FOR PCB LAYOUT IS ± 0.05

		深圳市华德共创科技有限公司 Shenzhen Huade co-create Technology Co.,LTD 电话: 0755-23304126 传真: 0755-29940187			
-TOLERANCES- UNLESS OTHERWISE SPECIFIED 公差参数表		 		TITLE: USB 3.1 TYPE C 16PIN 沉板1.6 产品名称: SMT单排母座L=6.5	
X.X	± 0.30	X.X*	$\pm 3^\circ$	APPD: 核准: PART NO: TYPE C-DB-113PWB 产品编号:	
X.XX	± 0.20	X.XX*	$\pm 2^\circ$	CHECK: 王建业	DATE SCALE UNIT CODE NUMBER
X.XXX	± 0.10	X.XXX*	$\pm 1^\circ$	DRAW: 黄艳兰	2016-03-12 1:1 mm A001

修订 REV NO	标记 MARK	修改摘要 REVISION DESCRIPTION	签名 SIGNATURE	日期 DATE
		NEW DRG		2016-03-12

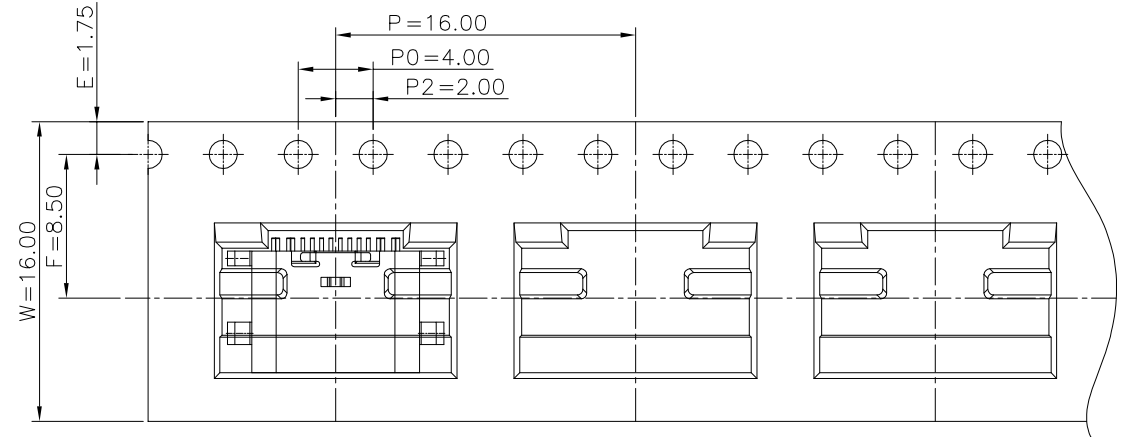
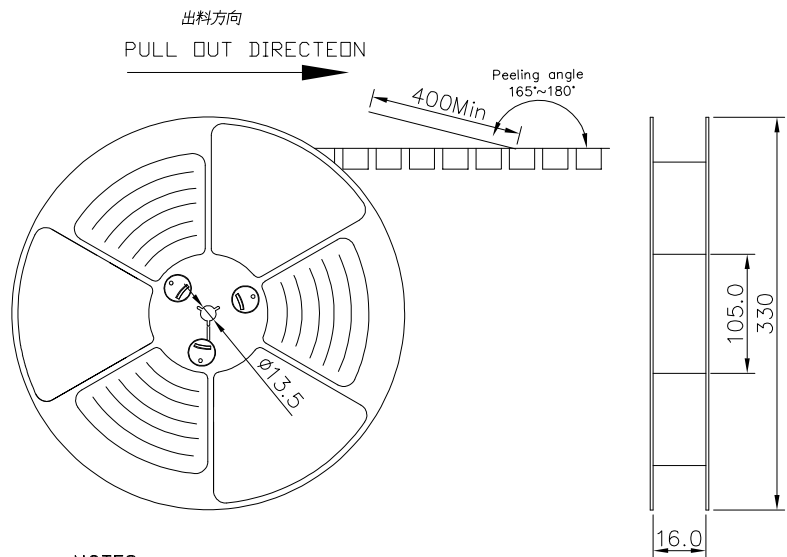

NOTES

1. 帶子引導長度
LEAD TAPE LENGTH
出料方向
PULL OUT DIRECTEON

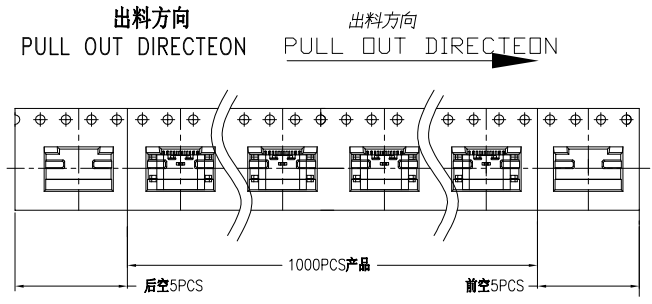

2. 上帶 剝力力為: 0.1~1.3N(10.2gf~130gf)
PEELING OFF FORCE OF TOP TAPE:0.1~1.3N(10.2gf~130gf)
出貨 運輸過程中一定注意:
THIS REQUIREMENT SHOULD BE APPLIED AT SHIPMENT:
卷帶在運輸過程中不能散開
PEELING OFF SHOULD NOT BE ALLOWED DURING TRANSPORTATION

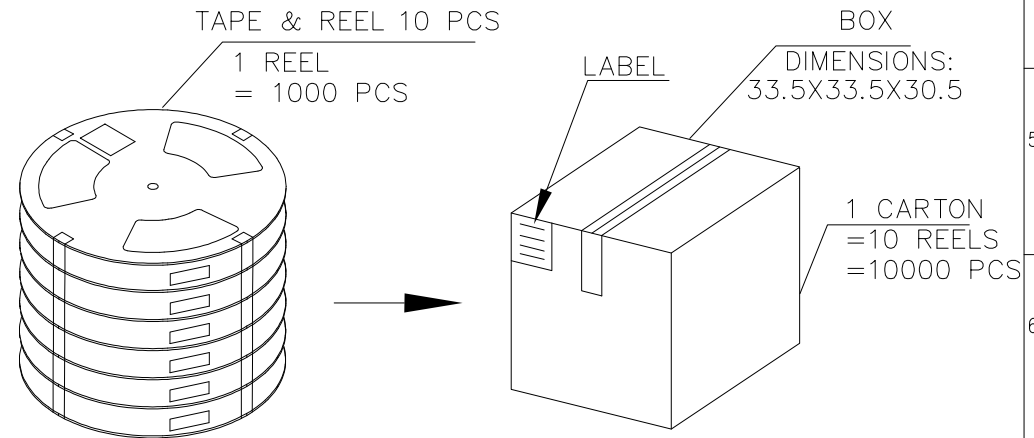

包裝明細表 (The detail of the packing) Carton						
產品料號 (Product No.)	包裝容量 (Packing Capacity)			重量 Weight (Kg)		
	pcs/box	boxs/Carton	Pcs/Box	N.W./Pcs	N.W./Box	G.W./Box
UCR06-4162X-00XR	1000	10	10000	---	---	---

		深圳市华德共创科技有限公司 Shenzhen Huade co-create Technology Co.,LTD 电话: 0755-23304126 传真: 0755-29940187			
-TOLERANCES- UNLESS OTHERWISE SPECIFIED 公差参数表				TITLE: USB 3.1 TYPE C 16PIN 沉板1.6 产品名称: SMT单排母座L=6.5	
X.X	±0.30	X.X*	±3°	APPD: 核准:	PART NO: 产品编号: TYPE C-DB-113PWB
X.XX	±0.20	X.XX*	±2°	CHECK: 校对: 王建业	DATE SCALE UNIT CODE NUMBER
X.XXX	±0.10	X.XXX*	±1°	DRAW: 绘图: 黄艳兰	2016-03-12 1:1 mm A001