

## 2A 27V Synchronous Buck Converter

(compatible to MP1482)

### Description

The HT1482A is a monolithic synchronous buck regulator. The device integrates 95 mΩ MOSFETS that provide 2A continuous load current over a wide operating input voltage of 4.5V to 27V. Current mode control provides fast transient response and cycle-by-cycle current limit. An adjustable soft-start prevents inrush current at turn on.

### Features

- 2A Output Current
- Wide 4.5V to 27V Operating Input Range
- Integrated Power MOSFET switches
- Output Adjustable from 0.925V to 0.8Vin Up to 96% Efficiency
- Programmable Soft-Start
- Stable with Low ESR Ceramic Output Capacitors
- Fixed 340KHZ Frequency
- Cycle-by-Cycle Over Current Protection
- Short Circuit Protection
- Input Under Voltage Lockout
- Package : SOP-8L

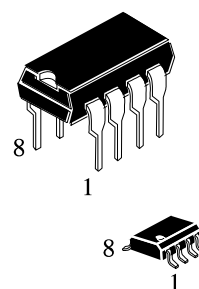

#### ORDERING INFORMATION

HT1482ANZ DIP8

HT1482ARZ SOP8

T<sub>A</sub> = -40° to 85°C for all packages.

### Applications

- Distributed Power Systems
- Networking Systems
- FPGA, DSP, ASIC Power Supplies
- Green Electronics/ Appliances
- Notebook Computers

### Typical Application Circuit

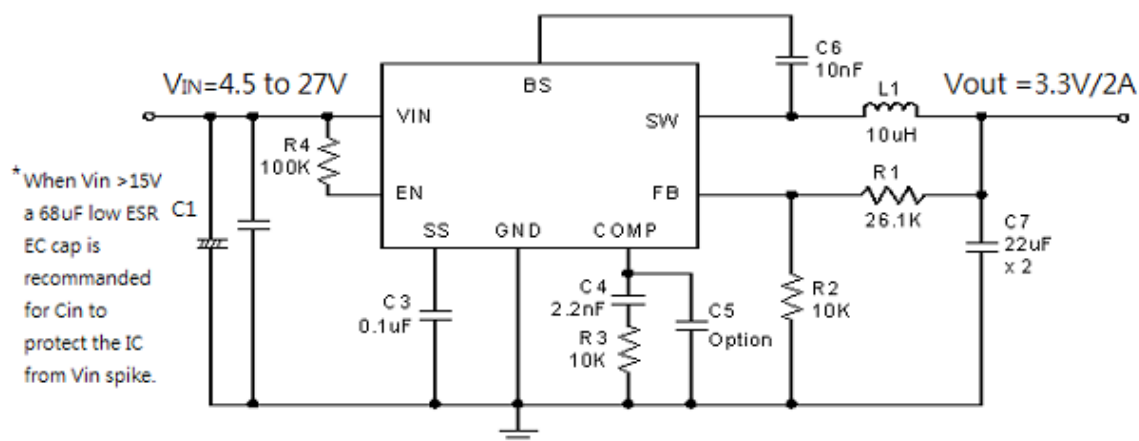

## Pin Assignments

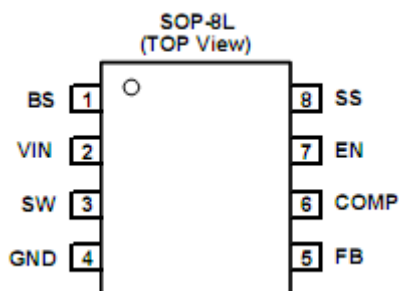

## Pin Descriptions

Pin Number	Name	Description
1	BS	Bootstrap. This pin acts as the positive rail for the high-side switch's gate driver. Connect a 0.01uF capacitor between BS and SW.
2	VIN	Input Supply. Bypass this pin to GND with a low ESR capacitor. See Input Capacitor in the Application Information section.
3	SW	Switch Output. Connect this pin to the switching end of the inductor.
4	GND	Ground.
5	FB	Feedback Input. The voltage at this pin is regulated to 0.925V. Connect to the resistor divider between output and ground to set output voltage.
6	COMP	Compensation Pin. See Stability Compensation in the Application Information section.
7	EN	Enable Input. When higher than 2.7V, this pin turns the IC on. When lower than 1.1V, this pin turns the IC off. Output voltage is discharged when the IC is off. This pin should not be left open. Recommend to put a 100KΩ pull up resistor to Vin for startup.
8	SS	Soft-Start Control Input. SS controls the soft-start period. Connect a capacitor from SS to GND to set the soft-start period. A 0.1uF capacitor sets the soft-start period to 15ms. To disable the soft-start feature, leave SS unconnected.



## Recommended Operating Conditions

Parameter	Min	Max	Unit
Input Supply Voltage	4.5	27 <sup>(1)</sup>	V
Operating Junction Temperature	-20	+125 <sup>(2)</sup>	°C

(Note (1): Operating the IC over this voltage is very easy to cause over voltage condition to VIN pin, SW pin, BS pin & EN pin)

(Note (2): If the IC experienced OTP, then the temperature may need to drop to <125 degree C to let the IC recover.)

## Electrical Characteristics (V<sub>IN</sub> = 12V, T<sub>A</sub> = 25°C unless otherwise specified.)

Parameter	Symbol	Test Conditions	Min	Typ	Max	Unit
Feedback Voltage	V <sub>FB</sub>	4.5V ≤ V <sub>IN</sub> ≤ 27V	0.900	0.925	0.950	V
Feedback Overvoltage Threshold				1.1		V
High-Side Switch-On Resistance*				95		mΩ
Low-Side Switch-On Resistance*				95		mΩ
High-Side Switch Leakage		V <sub>EN</sub> = 0V, V <sub>SW</sub> = 0V			10	μA
Upper Switch Current Limit*		Minimum Duty Cycle	2.7	3.5		A
COMP to Current Limit Transconductance	G <sub>COMP</sub>			3.3		A/V
Error Amplifier Transconductance	G <sub>EA</sub>	ΔI <sub>COMP</sub> = ±10μA		920		μA/V
Error Amplifier DC Gain*	A <sub>VEA</sub>			480		V/V
Switching Frequency	f <sub>SW</sub>			340		KHz
Short Circuit Switching Frequency		V <sub>FB</sub> = 0		120		KHz
Maximum Duty Cycle	D <sub>MAX</sub>	V <sub>FB</sub> = 0.8V		92		%
Minimum On Time*				220		nS
EN Shutdown Threshold Voltage		V <sub>EN</sub> Rising	1.1	1.4	2	V
EN Shutdown Threshold Voltage Hysteresis				180		mV
EN Lockout Threshold Voltage			2.2	2.5	2.7	V
EN Lockout Hysteresis				130		mV
Supply Current in Shutdown		V <sub>EN</sub> = 0		0.3	3.0	μA
IC Supply Current in Operation		V <sub>EN</sub> = 3V, V <sub>FB</sub> = 1.0V		1.3	1.5	mA
Input UVLO Threshold Rising	UVLO	V <sub>EN</sub> Rising	3.80	4.05	4.40	V
Input UVLO Threshold Hysteresis				100		mV
Soft-start Current		V <sub>SS</sub> = 0V		6		μA
Soft-start Period		C <sub>SS</sub> = 0.1μF		15		mS
Thermal Shutdown Temperature*		Hysteresis = 25°C		160		°C

Note: \* Guaranteed by design, not tested

## Application Description

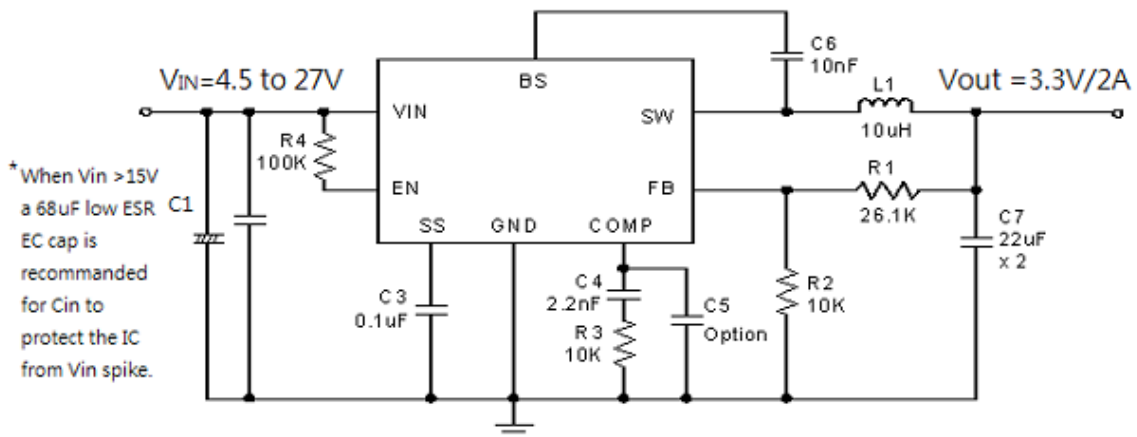

MP1482 Circuit, 3.3V/2A output

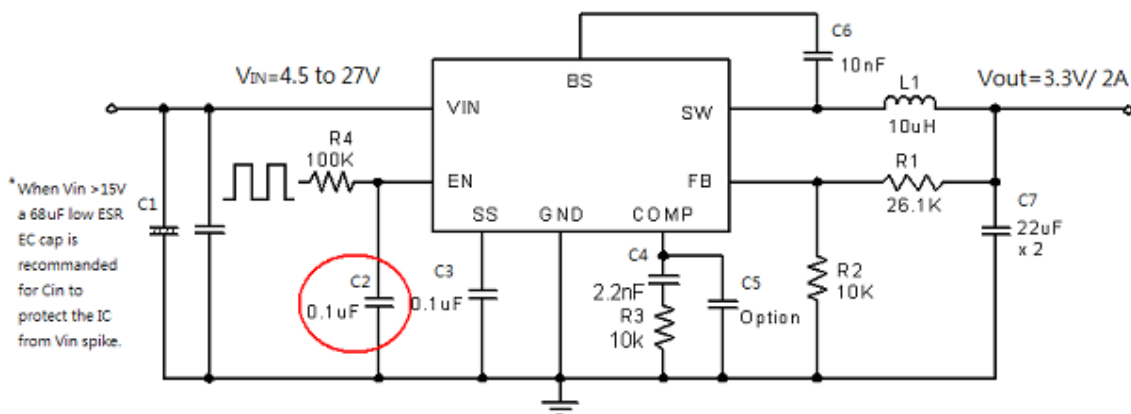

MP1482 Circuit, 3.3V/2A output with EN function

Note: C2 is required for separate EN signal.

## Output Voltage Setting

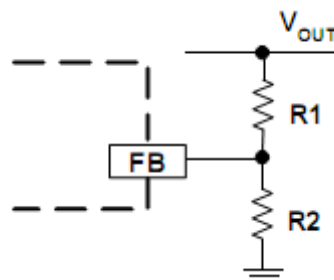

Figure1. Output Voltage Setting

Figure 1 shows the connections for setting the output voltage. Select the proper ratio of the two feedback resistors R1 and R2 based on the output voltage. Typically, use  $R2 \approx 10K\Omega$  and determine R1 from the following equation:

$$R1 = R2 \left( \frac{V_{OUT}}{0.925V} - 1 \right) \quad (1)$$

Table1 – Recommended Resistance Values

VOUT	R1	R2
1.0V	1.0 KΩ	12 KΩ
1.2V	3.0 KΩ	10 KΩ
1.8V	9.53 KΩ	10 KΩ
2.5V	16.9 KΩ	10 KΩ
3.3V	26.1 KΩ	10 KΩ
5V	44.2 KΩ	10 KΩ
12V	121 KΩ	10 KΩ

### Inductor Selection

The inductor maintains a continuous current to the output load. This inductor current has a ripple that is dependent on the inductance value: higher inductance reduces the peak-to-peak ripple current. The tradeoff for high inductance value is the increase in inductor core size and series resistance, and the reduction in current handling capability. In general, select an inductance value L based on the ripple current requirement:

$$L = \frac{V_{OUT} \cdot (V_{IN} - V_{OUT})}{V_{IN} f_{SW} I_{OUTMAX} K_{RIPPLE}} \quad (2)$$

Where VIN is the input voltage, VOUT is the output voltage, f<sub>sw</sub> is the switching frequency, IO<sub>UTMAX</sub> is the maximum output current, and KRIPPLE is the ripple factor. Typically, choose KRIPPLE = ~ 30% to correspond to the peak-to-peak ripple current being ~30% of the maximum output current.

With this inductor value, the peak inductor current is IO<sub>UT</sub> · (1 + KRIPPLE / 2). Make sure that this peak inductor current is less than the upper switch current limit. Finally, select the inductor core size so that it does not saturate at the current limit. Typical inductor values for various output voltages are shown in Table 2.

VOUT	1.0V	1.2V	1.5V	1.8V	2.5V	3.3V	5V	9V
L	4.7u	4.7u	10uH	10uH	10uH	10uH	10uH	22uH

Table2. Typical Inductor Values

### Input Capacitor

The input capacitor needs to be carefully selected to maintain sufficiently low ripple at the supply input of the converter. A low ESR Electrolytic (EC) capacitor is highly recommended. Since large current flows in and out of this capacitor during switching, its ESR also affects efficiency.

When EC cap is used, the input capacitance needs to be equal to or higher than 68uF. The RMS ripple current rating needs to be higher than 50% of the output current. The input capacitor should be placed close to the VIN and GND pins of the IC, with the shortest traces possible. The input capacitor can be placed a little bit away if a small parallel 0.1uF ceramic capacitor is placed right next to the IC.

When VIN is >15V, pure ceramic Cin (\* no EC cap) is not recommended. This is because the ESR of a

ceramic cap is often too small, Pure ceramic  $C_{in}$  will work with the parasite inductance of the input trace and forms a  $V_{in}$  resonant tank. When  $V_{in}$  is hot plug in/out, this resonant tank will boost the  $V_{in}$  spike to a very high voltage and damage the IC.

### Output Capacitor

The output capacitor also needs to have low ESR to keep low output voltage ripple. In the case of ceramic output capacitors, RESR is very small and does not contribute to the ripple. Therefore, a lower capacitance value can be used for ceramic capacitors. In the case of tantalum or electrolytic capacitors, the ripple is dominated by RESR multiplied by the ripple current. In that case, the output capacitor is chosen to have sufficiently low ESR.

For ceramic output capacitors, typically choose of about 22 $\mu$ F. For tantalum or electrolytic capacitors, choose a capacitor with less than 50m $\Omega$  ESR.

### Optional Schottky Diode

During the transition between high-side switch and low-side switch, the body diode of the low side power MOSFET conducts the inductor current. The forward voltage of this body diode is high. An optional Schottky diode may be paralleled between the SW pin and GND pin to improve overall efficiency. Table 3 lists example Schottky diodes and their Manufacturers.

Table 3 – Diode Selection Guide

$V_{in}$ max	Part Number	Voltage/Current Rating	Vendor
<20V	B130	30V, 1A	Lite-on semiconductor corp.
<20V	SK13	30V, 1A	Lite-on semiconductor corp.
>20V	B140	40V, 1A	Lite-on semiconductor corp.
>20V	SK14	40V, 1A	Lite-on semiconductor corp.

### Stability Compensation

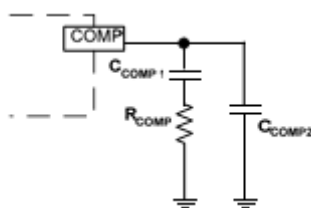

$C_{COMP2}$  is needed only for high ESR output capacitor

Figure2. Stability Compensation

The feedback loop of the IC is stabilized by the components at the COMP pin, as shown in Figure 2. The DC loop gain of the system is determined by the following equation:

$$A_{VDC} = \frac{0.925V}{I_{OUT}} A_{VEA} G_{COMP} \quad (4)$$

The dominant pole P1 is due to CCOMP1:

$$f_{P1} = \frac{G_{EA}}{2\pi A_{VEA} C_{COMP1}} \quad (5)$$

The second pole P2 is the output pole:

$$f_{P2} = \frac{I_{OUT}}{2\pi V_{OUT} C_{OUT}} \quad (6)$$

The first zero Z1 is due to RCOMP and CCOMP:

$$f_{Z1} = \frac{1}{2\pi R_{COMP} C_{COMP1}} \quad (7)$$

And finally, the third pole is due to RCOMP and CCOMP2 (if CCOMP2 is used):

$$f_{P3} = \frac{1}{2\pi R_{COMP} C_{COMP2}} \quad (8)$$

The following steps should be used to compensate the IC:

STEP1. Set the crossover frequency at 1/10 of the switching frequency via RCOMP:

$$R_{COMP} = \frac{2\pi V_{OUT} C_{OUT} f_{SW}}{10 G_{EA} G_{COMP} \cdot 0.925V} \quad (9)$$

But limit  $R_{COMP}$  to 10K $\Omega$  maximum. More than 10 K $\Omega$  is easy to cause overshoot at power on.

STEP2. Set the zero  $f_{Z1}$  at 1/4 of the crossover frequency. If  $R_{COMP}$  is less than 10K $\Omega$ , the equation for  $C_{COMP1}$  is:

$$C_{COMP1} = \frac{0.637}{R_{COMP} \times fc} (F) \quad (10)$$

STEP3. If the output capacitor's ESR is high enough to cause a zero at lower than 4 times the crossover frequency, an additional compensation capacitor  $C_{COMP2}$  is required. The condition for using  $C_{COMP2}$  is:

$$\pi \times C_{OUT} \times R_{ESR} \times fs \geq 1 \quad (11)$$

And the proper value for  $C_{COMP2}$  is:

$$C_{COMP2} = \frac{C_{OUT} R_{ESR} C_{OUT}}{R_{COMP}} \quad (12)$$

Though  $C_{COMP2}$  is unnecessary when the output capacitor has sufficiently low ESR, a small value  $C_{COMP2}$  such as 100pF may improve stability against PCB layout parasitic effects



Table 4— Component Selection Guide for Stability Compensation

Vin Rang(V)	Vout (V)	Cout	Rcomp (R3) (kΩ)	Ccomp (C4) (nF)	Ccomp2 (C5) (pF)	Inductor (uH)
5 – 12	1.0	22uF x2 Ceramic	3.3	5.6	none	4.7
5 - 15	1.2		3.9	4.7	none	4.7
5 - 15	1.8		5.6	3.3	none	10
5 - 15	2.5		8.2	2.2	none	10
5 - 15	3.3		10	2	none	10
7 - 15	5		10	3.3	none	10
5 - 12	1.0	470uF/6.3V/ 120mΩ	10	6.8	680	4.7
5 - 15	1.2					10
5 - 23	1.8					
5 - 27	2.5					
5 -27	3.3					
7 -27	5					

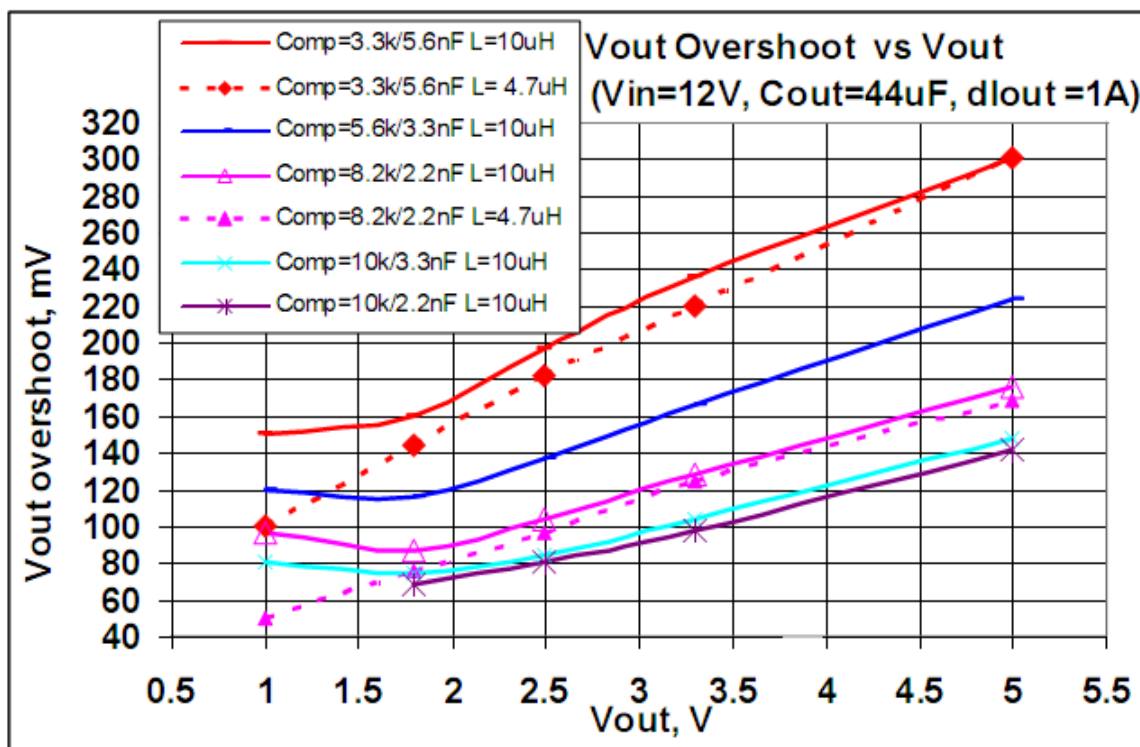

Figure3. Load Transient Testing vs Compensation Value

## Typical Performance Characteristics

(VIN=12V, Io=0 mA, Temperature = 25 degree C, unless otherwise specified)

Light Load Operation (No load)

Heavy Load Operation (2A Load)

VIN=12V, Iin=8.2 mA, Vout=3,3V

VIN=12V, Vout=3,3V

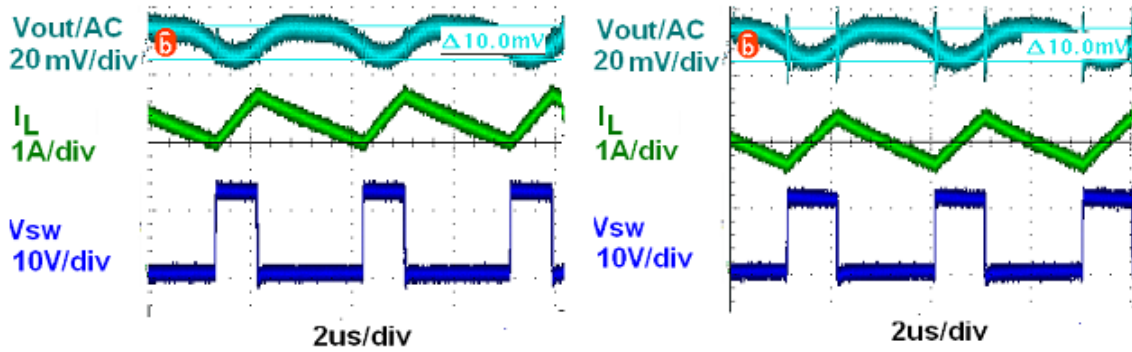

Startup  $V_{in}=12V$ ,  $V_{out}=3.3V$ ,  $I_{out}=1A$   
 through  $V_{in}$ .

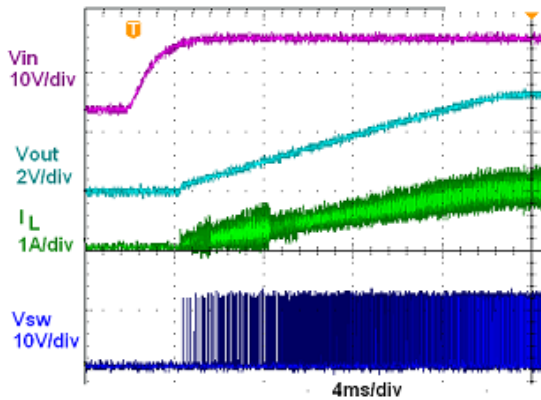

through Enable.

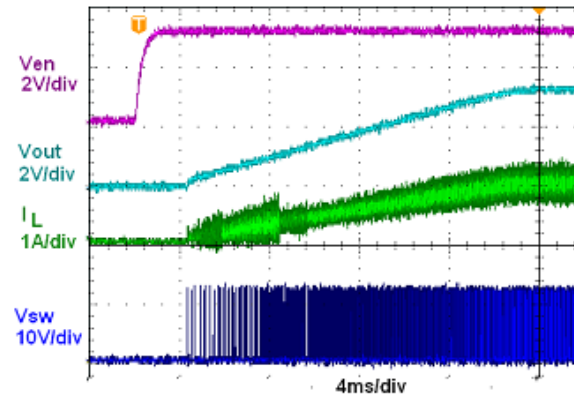

Short Circuit Protection  $V_{in}=12V$

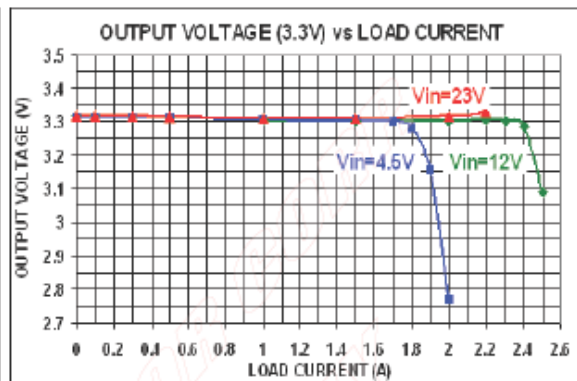
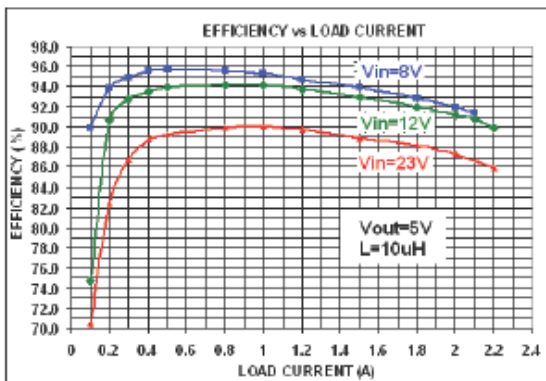
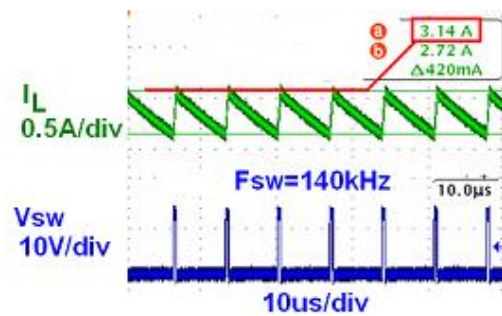
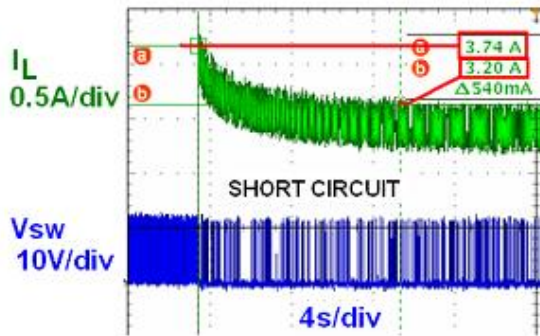

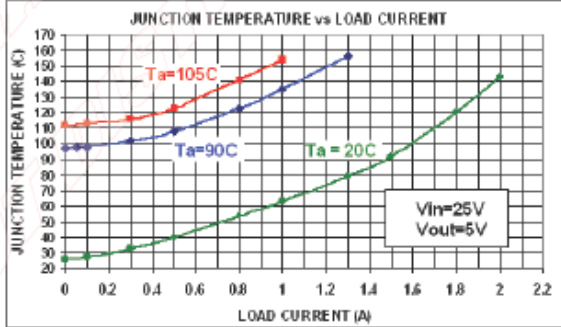
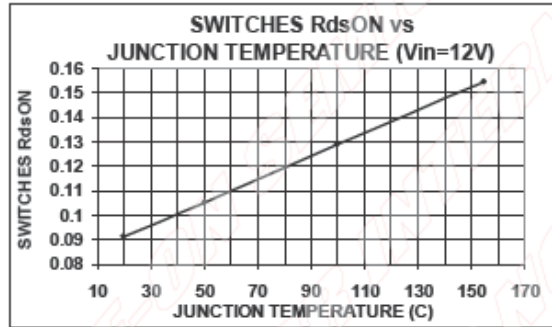
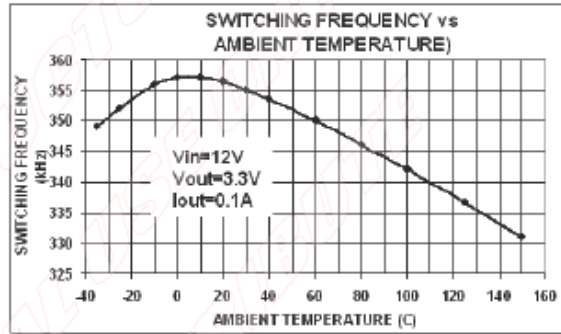
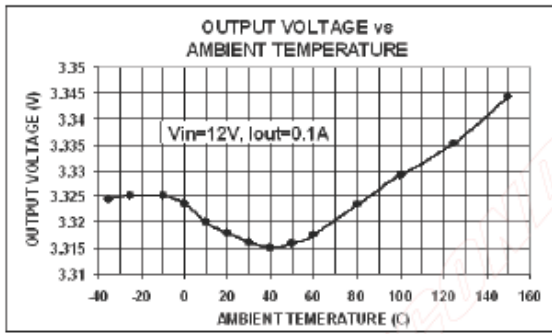

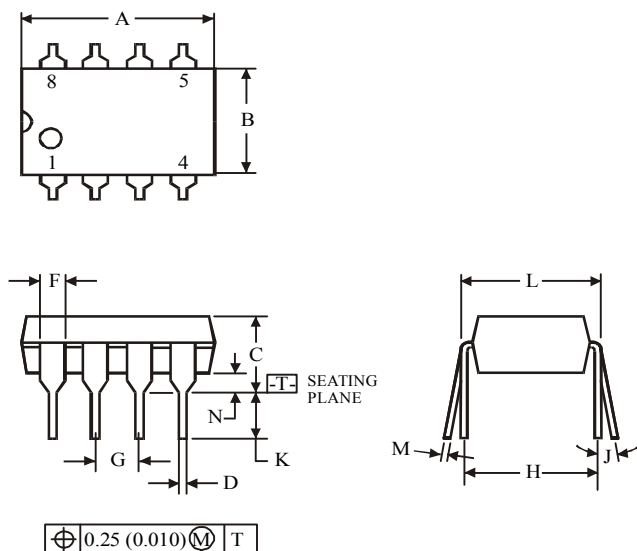
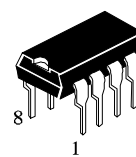
**(DIP8)**

Symbol	Dimension, mm	
	MIN	MAX
A	8.51	10.16
B	6.1	7.11
C		5.33
D	0.36	0.56
F	1.14	1.78
G	2.54	
H	7.62	
J	0°	10°
K	2.92	3.81
L	7.62	8.26
M	0.2	0.36
N	0.38	

**NOTES:**

- Dimensions "A", "B" do not include mold flash or protrusions.  
Maximum mold flash or protrusions 0.25 mm (0.010) per side.

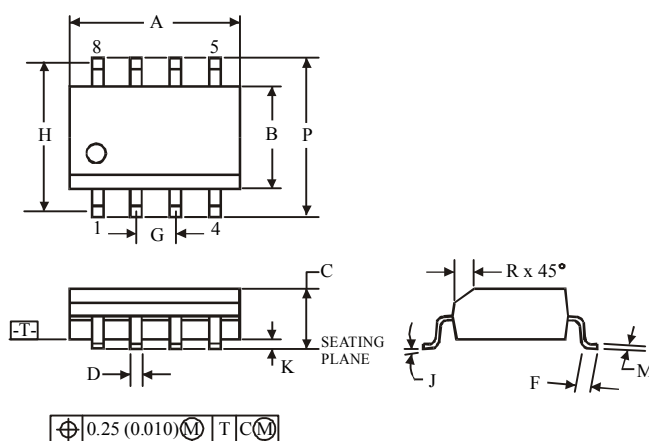
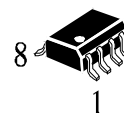
**(SOP8)**

Symbol	Dimension, mm	
	MIN	MAX
A	4.8	5
B	3.8	4
C	1.35	1.75
D	0.33	0.51
F	0.4	1.27
G	1.27	
H	5.72	
J	0°	8°
K	0.1	0.25
M	0.19	0.25
P	5.8	6.2
R	0.25	0.5

**NOTES:**

- Dimensions A and B do not include mold flash or protrusion.
- Maximum mold flash or protrusion 0.15 mm (0.006) per side for A; for B - 0.25 mm (0.010) per side.