

DSD4V5TC

DSD4V5TC Single line Bi-directional TVS Diode

General description

Single line Bi-directional TVS Diode
in a SOD-323 Package.

FEATURES

- Low clamping voltage
- Low leakage current
- Working voltages : 4.5V
- Peak power dissipation:3200W (8/20 μ s)
- Solid-state silicon-avalanche technology

APPLICATIONS:

- Power lines Microprocessor based equipment
- Personal Digital Assistants (PDA's)
- Microprocessors based equipment
- Notebooks, Desktops, and Servers
- Cell phone Handsets and Accessories
- Notebooks, Desktops, and Servers
- Portable Electronics
- Peripherals

MACHANICAL DATA

- SOD-323 package
- Flammability Rating: UL 94V-0
- High temperature soldering guaranteed:260°C/10s

Package Outline



SOD-323 Package

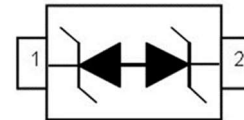

PIN CONFIGURATION

Device Marking:

Device Type	Marking
DSD4V5TC	D4

ABSOLUTE MAXIMUM RATING

Symbol	Parameter	Value	Units
V _{ESD}	ESD per IEC 61000-4-2 (Air)	±30	kV
	ESD per IEC 61000-4-2 (Contact)	±30	
P _{PP}	Peak Pulse Power (8/20 μ s)	3200	W
T _{OPT}	Operating Temperature	-55~125	°C
T _{STG}	Storage Temperature	-55~150	°C
TL	Lead Soldering Temperature	260	°C

DSD4V5TC

ELECTRICAL CHARACTERISTICS (T _{amb} =25°C)						
Symbol	Parameter	Test Condition	Min	Typ	Max	Units
V _{RWM}	Reverse Working Voltage				4.5	V
V _{BR}	Reverse Breakdown Voltage	I _T = 1mA	4.6	5.2	6.4	V
I _R	Reverse Leakage Current	V _{RWM} = 4.5V			1	uA
I _{PP}	Peak Pulse Current	t _p = 8/20μs			160	A
V _C	Clamping Voltage	I _{PP} = 50A, t _p = 8/20μs		8.5	11	V
		I _{PP} = 100A, t _p = 8/20μs		12	14	V
		I _{PP} = 160A, t _p = 8/20μs		17	20	V
C _J	Junction Capacitance	V _R = 0V, f = 1MHz		300	500	pF

Typical Characteristic:

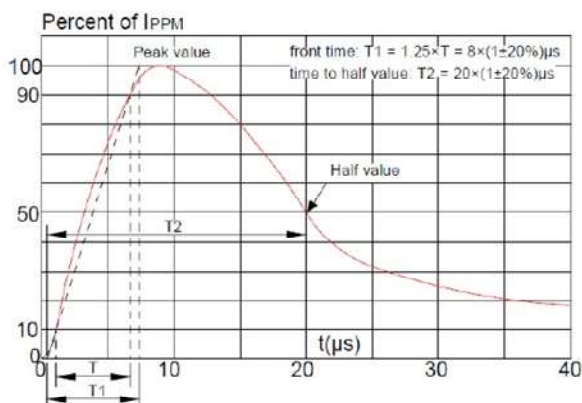

Pulse Waveform (8/20us)

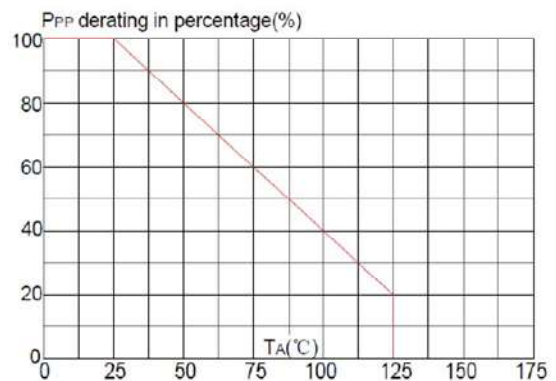

Pulse Derating Curve

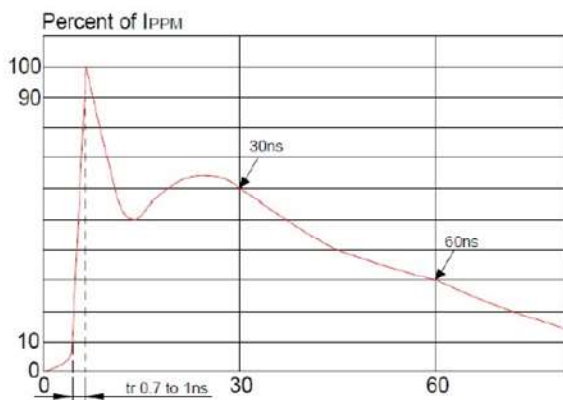

ESD Clamping(8kV Contact Discharge)

DSD4V5TC

SOD-323 PACKAGE OUTLINE DIMENSIONS

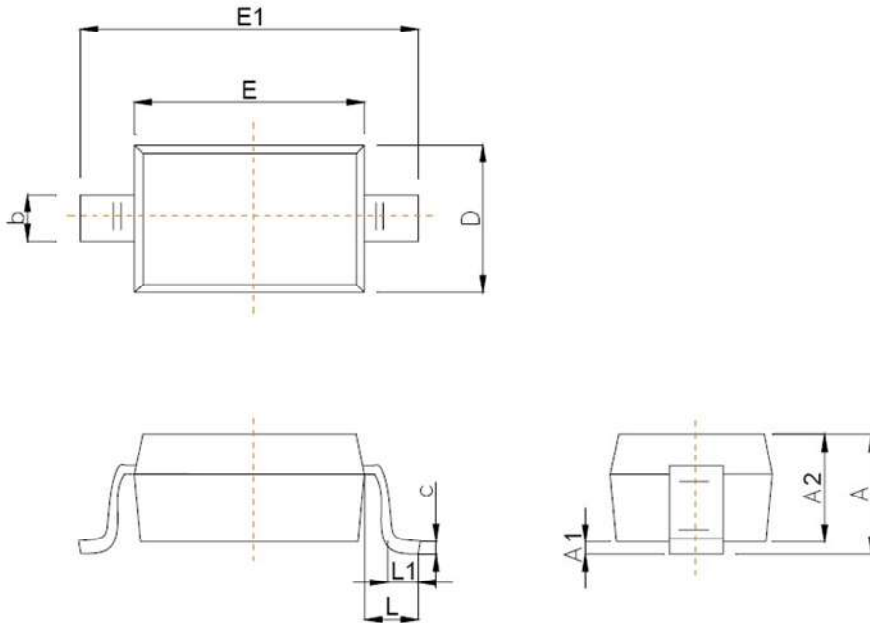

Symbol	Dimensions In Millimeters	
	Min	Max
A		1.00
A1	0.000	0.100
A2	0.800	0.900
b	0.250	0.350
c	0.080	0.150
D	1.200	1.400
E	1.600	1.800
E1	2.500	2.700
e	1.800	2.040
L	0.475 REF	
L1	0.250	0.400
θ	0°	8°

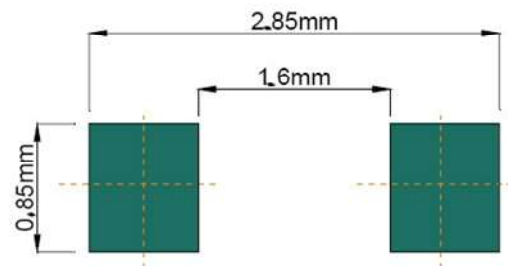

Recommended Pad outline

Important Notice and Disclaimer

DOESHARE has used reasonable care in preparing the information included in this document, but DOESHARE does not warrant that such information is error free. DOESHARE assumes no liability whatsoever for any damages incurred by you resulting from errors in or omissions from the information included herein.

DOESHARE no warranty, representation or guarantee regarding the documents, circuits and products specification, DOESHARE reservation rights to make changes for any documents, products, circuits and specifications at any time without notice.

Purchasers are solely responsible for the choice, selection and use of the DOESHARE products and services described herein, and DOESHARE assumes no liability whatsoever relating to the choice, selection or use of the products and services described herein.

No license, express or implied, by implication or otherwise under any intellectual property rights of DOESHARE.

Resale of DOESHARE products with provisions different from the statements and/or technical features set forth in this document shall immediately void any warranty granted by DOESHARE for the DOESHARE product or service described herein and shall not create or extend in any manner whatsoever, any liability of DOESHARE.