

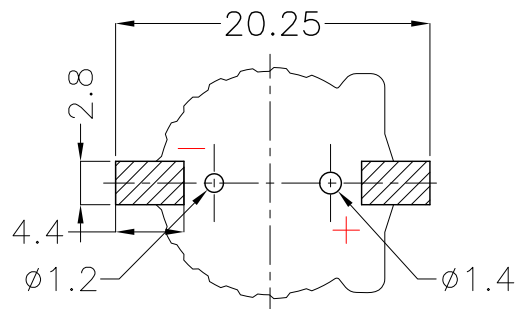

REV.	ECN NO.	REVISED	DATE

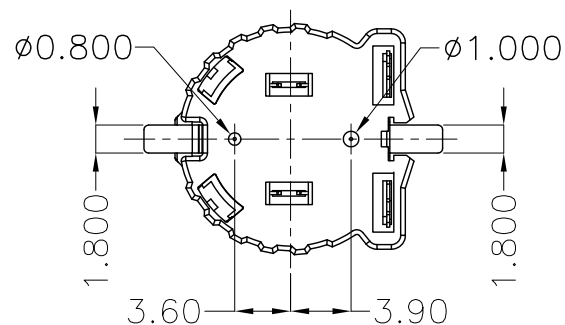
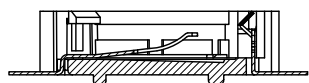
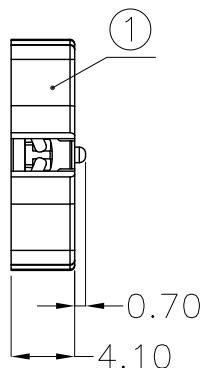
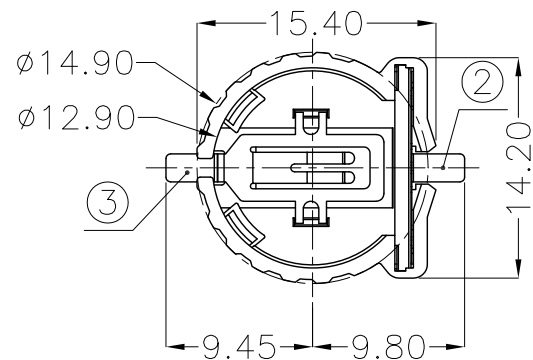

PCB Layout Diagram
Top View

1.MATERIAL:

- a.HOUSING:PPS
- b.CONTACT:PHOSPHOR BRONZE
(SURFACE PLATING:AU1u")

SEE ORDERING INFORMATION

2.ELECTRIC:

- a.CONTACT RESISTANCE: 30 MILLIOHMS MAX
- b.INSULATION RESISTANCE: 1000 MEGA OHMS MIN
- c.DIELECTNIC VOLTAGE: 500V AC ONE SEC LEVEL
- d.OPERATING TEMPERATURE: -25°C~ +85°C

ORDERING INFORMATION

BS-12-B***003

电池座系列

BS-12系列

SMT 180° TYPE

PLATING:
A-Au1U"
J-Ni100U"~120U"
K-Sn100U"~120U"

MATERIAL:
1A-PBT BLACK
1B-PA66 BLACK
2A-PPA BROWN
2B-PPA BLACK
3A-PPS BROWN
3B-PPS BLACK
4A-LCP WHITE
4B-LCP BLACK



UNLESS OTHERWISE SPECIFIED TOLERANCES		MYOUNG 美阳 www.meiyangdz.com	
DECIMALS: X :±0.30 X.X :±0.25 X.XX :±0.20 X.XXX :±0.10	ANGLES: X :±1° X.X :±0.5°	DSND YangFeng	DATE 2018-10-24
WEIGHT: 0.63g		CHKD ZhouRuicai	DATE 2018-10-24
SHEET 1 OF 1		APVD XueShun Yong	DATE 2018-10-24
TITLE: BS-1220-2 PPS SMT		SCALE: 2:1	SIZE: A4
PART NO.: BS-12-B3BA003		VIEW:	REV.: A/0
DRAW NO.:MY-CP-0152		UNIT: mm	OBJECT: MY

NO.	PART NAME	Q'TY	MATERIAL	PLATING & COLOR
3	TERMINAL(-)	1	PHOSPHOR BRONZE, T=0.20mm	Gold Plating and Ni Under-Plating
2	TERMINAL(+)	1	PHOSPHOR BRONZE, T=0.20mm	Gold Plating and Ni Under-Plating
1	HOUSING	1	PPS	BLACK