

1、Description

The 431 series are three-terminal adjustable regulators with guaranteed thermal stability over applicable temperature ranges. The output voltage may be set to any value between V_{ref} (approximately 2.495 volts) and 36 volts with two external resistors. These devices have a typical dynamic output impedance of 0.2Ω . Active output circuitry provides a very sharp turn-on characteristic, making these devices in many applications.

2、Features

- Programmable output voltage.
- Temperature coefficient is 50 ppm/°C typical.
- Temperature compensated for operation over.
- Full temperature range.
- Low output noise voltage.
- Fast turn on response.

3、Pinning information

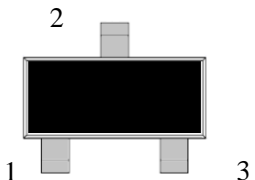
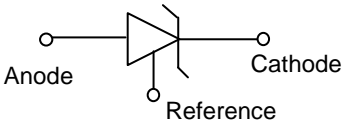
PIN	Description	Simplified outline	Symbol
1	Reference (R)	 <p style="text-align: center;">SOT-23</p>	
2	Anode (A)		
3	Cathode(K)		

4、Classifications

Rank	A	B	C
V_{REF}	$2.495 \pm 2\%$	$2.495 \pm 1\%$	$2.495 \pm 0.5\%$

5、Absolute Maximum Rating

(Operating temperature ranges applies unless otherwise specified)

Symbol	Characteristics	Value	Unit
V_{KA}	Cathode voltage	37	V
I_K	Cathode Current Range(continuous)	-100 ~ +150	mA
R_{REF}	Reference Input Current Range	0.05 ~ +10	mA
P_D	Power Dissipation	300	mW
T_{opr}	Operating Temperature Range	0 ~ +70	°C
T_{stg}	Storage Temperature Range	-65 ~ +150	°C

6、Electrical Characteristics ($T_a = 25^\circ\text{C}$ unless otherwise specified)

SYMBOL	PARAMETER	CONDITIONS	MIN	TYP	MAX	UNIT
V_{REF}	Reference Input Voltage A B C	$V_{KA} = V_{REF}; I_K = 10\text{mA}$	2.445	2.495	2.545	V
			2.470	2.495	2.520	
			2.483	2.495	2.507	
$V_{REF(dev)}$	Deviation of Reference Input Voltage Over-Temperature	$V_{KA} = V_{REF}; I_K = 10\text{mA}$ $T_{min} \leq T_a \leq T_{max}$	-	4	17	mV
$\frac{\Delta V_{REF}}{\Delta V_{KA}}$	Ratio of change in Reference Input Voltage to the change in Cathode Voltage	$I_K = 10\text{mA}$ $\Delta V_{KA} = 10\text{V} - V_{REF}$	-	-1.4	-2.7	mV
		$I_K = 10\text{mA}$ $\Delta V_{KA} = 36\text{V} - 10\text{V}$	-	-1.0	-2.0	V
I_{REF}	Reference Input Current	$I_K = 10\text{mA}, R_1 = 10\text{K}\Omega, R_2 = \infty$	-	2	4	μA
$I_{REF(dev)}$	Deviation of Reference Input Current Over full Temperature Range	$I_K = 10\text{mA}, R_1 = 10\text{K}\Omega, R_2 = \infty; T_a = \text{Full Range}$	-	0.4	1.2	μA
$I_{K(min)}$	Minimum Cathode Current for Regulation	$V_{KA} = V_{REF}$	-	0.4	1.0	mA
$I_{K(off)}$	Off-state Cathode Current	$V_{KA} = 36\text{V}; V_{REF} = 0$	-	0.1	1.0	μA
Z_{KA}	Dynamic impedance	$V_{KA} = V_{REF}; f \leq 1.0\text{KHZ}$ $I_K = 1 \text{ to } 100\text{mA}$	-	0.2	0.5	Ω

7、Functional Block Diagram

Representative Block Diagram

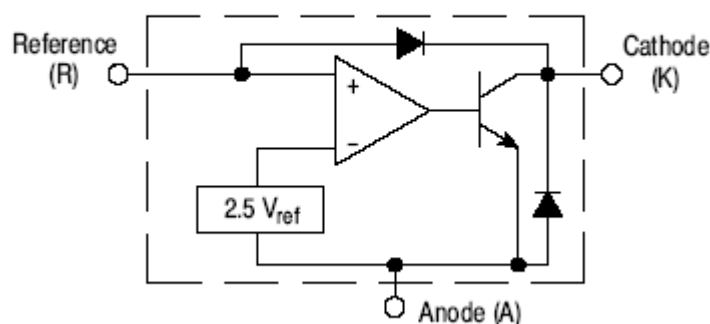

8、Test circuits

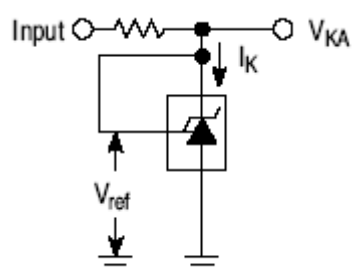

Figure1. Test Circuit for $V_{KA} = V_{REF}$

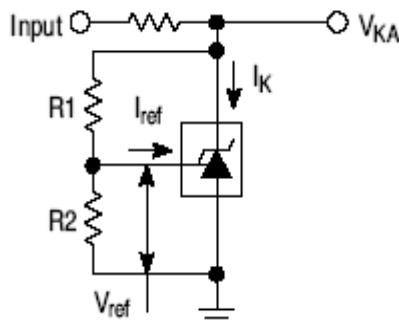

Figure2. Test Circuit for $V_{KA} > V_{REF}$

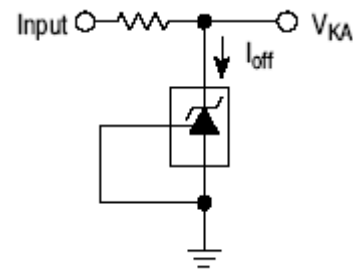

Figure3. Test Circuit for I_{off}

9. Characteristics Curve

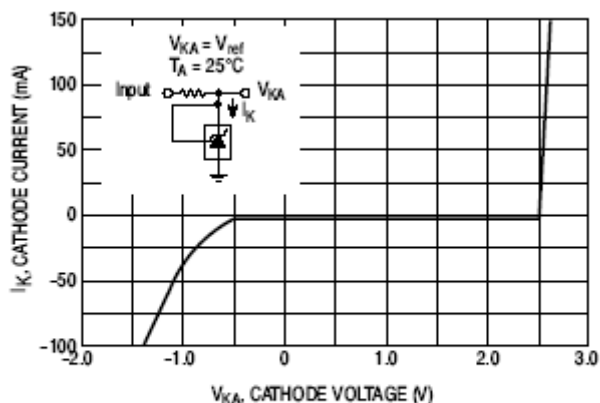

Figure 4. Cathode Current versus Cathode Voltage

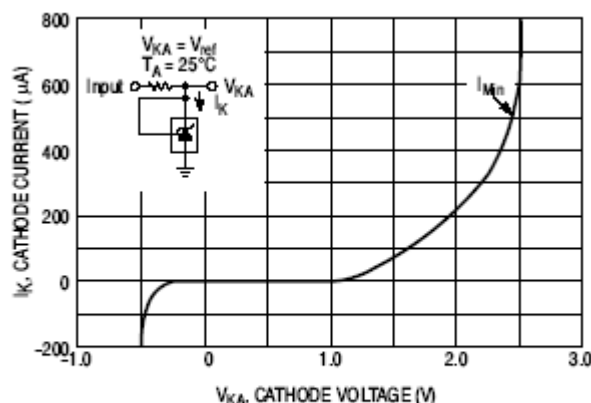

Figure 5. Cathode Current versus Cathode Voltage

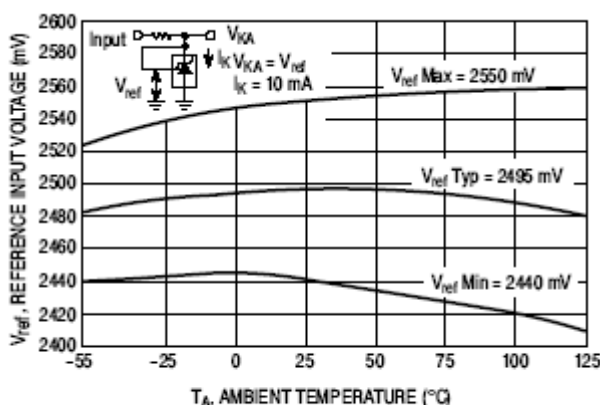

Figure 6. Reference Input Voltage versus Ambient Temperature

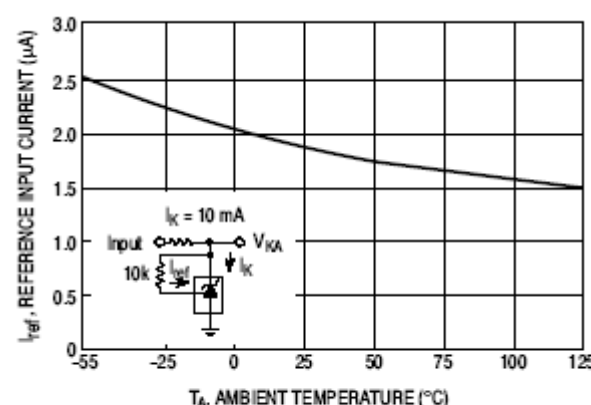

Figure 7. Reference Input Current versus Ambient Temperature

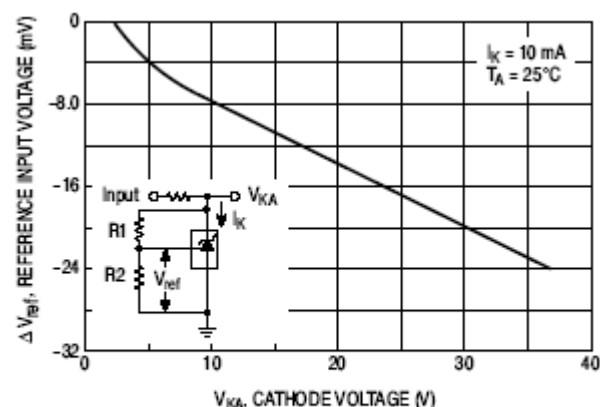

Figure 8. Change in Reference Input Voltage versus Cathode Voltage

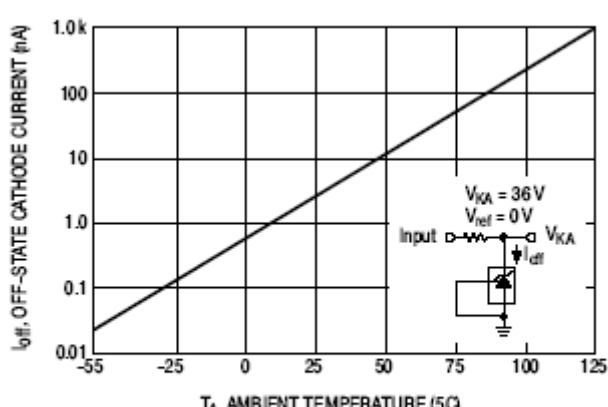
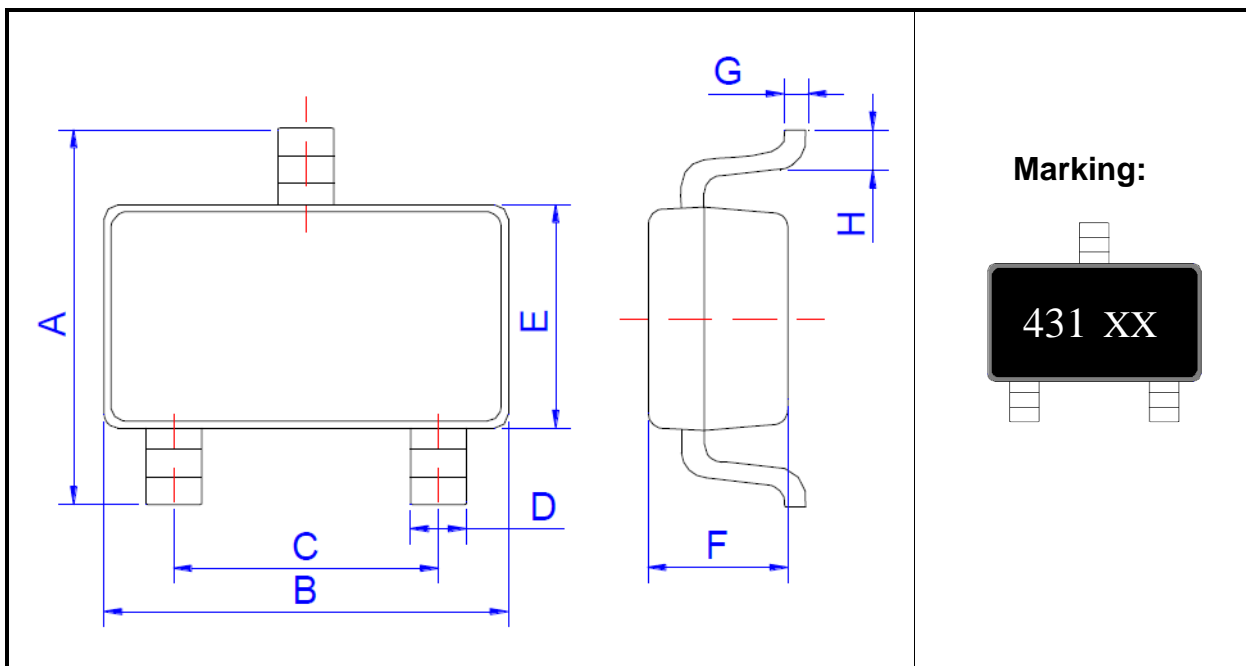

Figure 9. Off-State Cathode Current versus Ambient Temperature

10、 Package outline(SOT-23)



DIM	Inches			Millimeters		
	Min	Type	Max	Min	Type	Max
A	0.104		0.116	2.65		2.95
B		0.115			2.92	
C		0.075			1.90	
D	0.014		0.018	0.35		0.45
E		0.051			1.30	
F		0.043			1.10	
G		0.006			0.16	
H	0.010		0.022	0.25		0.55