

### Features

- 20V/7A,  
 $R_{DS(ON)} = 13m\Omega(Typ.)@V_{GS}=4.5V$   
 $R_{DS(ON)} = 16m\Omega(Typ.)@V_{GS}=2.5V$
- Low  $R_{DS(ON)}$
- Super High Dense Cell Design
- Reliable and Rugged
- Lead Free and Green Devices Available (RoHS Compliant)

### Pin Description

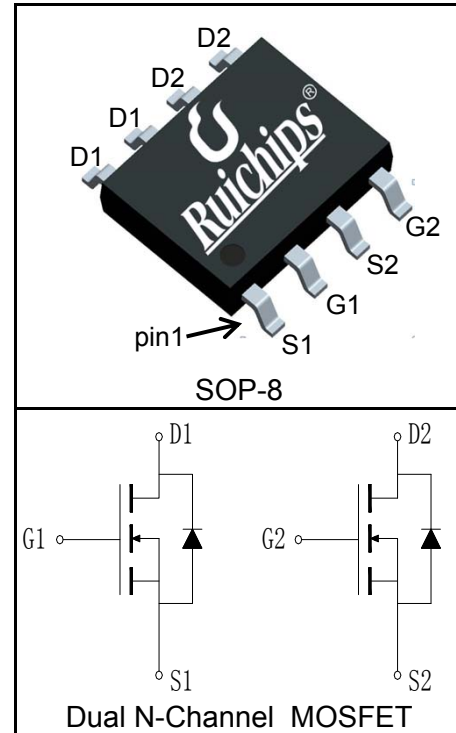

### Applications

- Power Management

### Absolute Maximum Ratings

Symbol	Parameter	Rating	Unit
<b>Common Ratings</b> ( $T_A=25^\circ C$ Unless Otherwise Noted)			
$V_{DSS}$	Drain-Source Voltage	20	V
$V_{GSS}$	Gate-Source Voltage	$\pm 12$	
$T_J$	Maximum Junction Temperature	150	$^\circ C$
$T_{STG}$	Storage Temperature Range	-55 to 150	$^\circ C$
$I_S$	Diode Continuous Forward Current	$T_A=25^\circ C$ 7	A
<b>Mounted on Large Heat Sink</b>			
$I_{DP}^{①}$	300 $\mu s$ Pulse Drain Current Tested	$T_A=25^\circ C$ 28	A
$I_D^{②}$	Continuous Drain Current( $V_{GS}=4.5V$ )	$T_A=25^\circ C$ 7	A
		$T_A=70^\circ C$ 5.6	
$P_D$	Maximum Power Dissipation	$T_A=25^\circ C$ 2.5	W
		$T_A=70^\circ C$ 1.6	
$R_{\theta JC}$	Thermal Resistance-Junction to Case	-	$^\circ C/W$
$R_{\theta JA}^{③}$	Thermal Resistance-Junction to Ambient	50	$^\circ C/W$
<b>Drain-Source Avalanche Ratings</b>			
$E_{AS}^{④}$	Avalanche Energy, Single Pulsed	-	mJ

**Electrical Characteristics** ( $T_A=25^{\circ}\text{C}$  Unless Otherwise Noted)

Symbol	Parameter	Test Condition	RU20D7H			Unit
			Min.	Typ.	Max.	
<b>Static Characteristics</b>						
$BV_{DSS}$	Drain-Source Breakdown Voltage	$V_{GS}=0V, I_{DS}=250\mu A$	20			V
$I_{DSS}$	Zero Gate Voltage Drain Current	$V_{DS}=20V, V_{GS}=0V$			1	$\mu A$
		$T_J=125^{\circ}\text{C}$			30	
$V_{GS(th)}$	Gate Threshold Voltage	$V_{DS}=V_{GS}, I_{DS}=250\mu A$	0.4		1.1	V
$I_{GSS}$	Gate Leakage Current	$V_{GS}=\pm 12V, V_{DS}=0V$			$\pm 100$	nA
$R_{DS(ON)}^{(5)}$	Drain-Source On-state Resistance	$V_{GS}=4.5V, I_{DS}=7A$		13	16	$m\Omega$
		$V_{GS}=2.5V, I_{DS}=5A$		16	20	$m\Omega$
<b>Diode Characteristics</b>						
$V_{SD}^{(5)}$	Diode Forward Voltage	$I_{SD}=1A, V_{GS}=0V$			1	V
$t_{rr}$	Reverse Recovery Time	$I_{SD}=7A, di_{SD}/dt=100A/\mu s$		19		ns
$Q_{rr}$	Reverse Recovery Charge			9		nC
<b>Dynamic Characteristics</b> <sup>⑥</sup>						
$R_G$	Gate Resistance	$V_{GS}=0V, V_{DS}=0V, F=1\text{MHz}$		1		$\Omega$
$C_{iss}$	Input Capacitance	$V_{GS}=0V,$ $V_{DS}=10V,$ Frequency=1.0MHz		670		pF
$C_{oss}$	Output Capacitance			135		
$C_{rss}$	Reverse Transfer Capacitance			65		
$t_{d(ON)}$	Turn-on Delay Time	$V_{DD}=10V, I_{DS}=7A,$ $V_{GEN}=4.5V, R_G=4.7\Omega$		9		ns
$t_r$	Turn-on Rise Time			16		
$t_{d(OFF)}$	Turn-off Delay Time			45		
$t_f$	Turn-off Fall Time			21		
<b>Gate Charge Characteristics</b> <sup>⑥</sup>						
$Q_g$	Total Gate Charge	$V_{DS}=16V, V_{GS}=4.5V,$ $I_{DS}=7A$		13		nC
$Q_{gs}$	Gate-Source Charge			2.3		
$Q_{gd}$	Gate-Drain Charge			3.9		

- Notes:
- ① Pulse width limited by safe operating area.
  - ② Calculated continuous current based on maximum allowable junction temperature.
  - ③ When mounted on 1 inch square copper board,  $t \leq 10\text{sec}$ . The value in any given application depends on the user's specific board design.
  - ④ Limited by  $T_{Jmax}$ . Starting  $T_J = 25^{\circ}\text{C}$ .
  - ⑤ Pulse test; Pulse width  $\leq 300\mu s$ , duty cycle  $\leq 2\%$ .
  - ⑥ Guaranteed by design, not subject to production testing.

**Typical Characteristics**

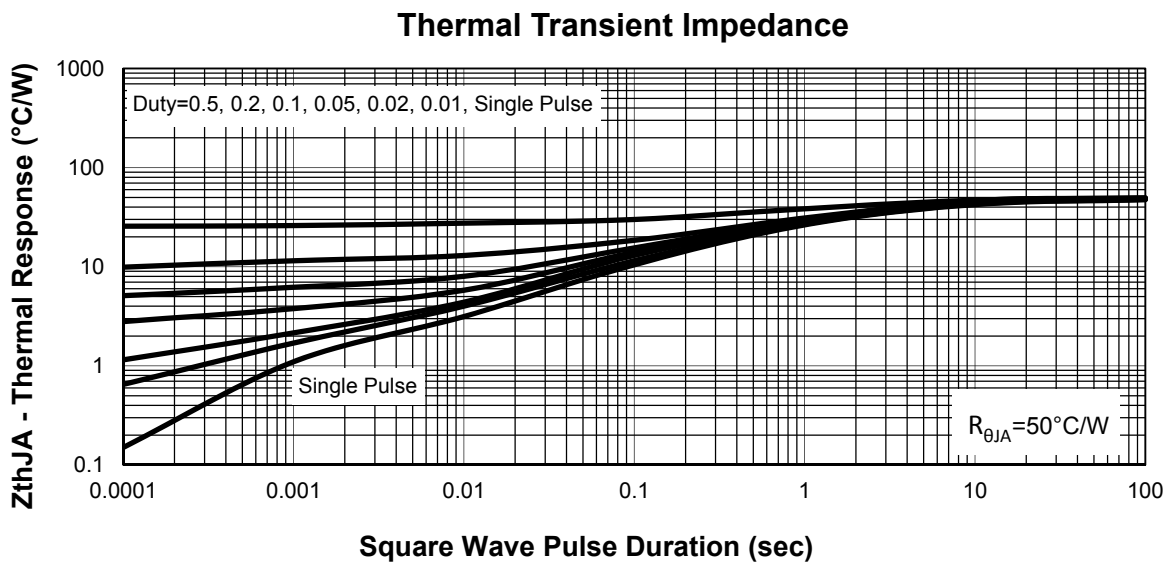
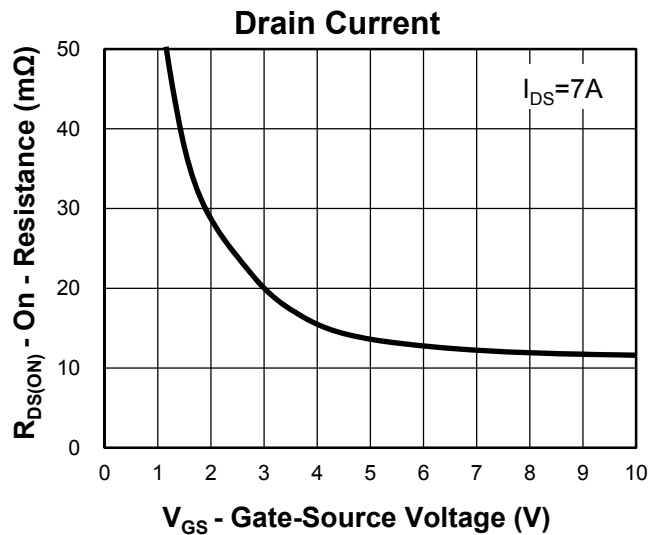
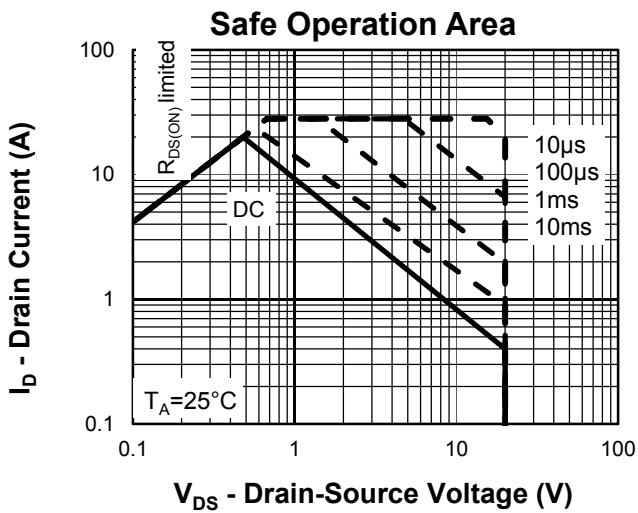
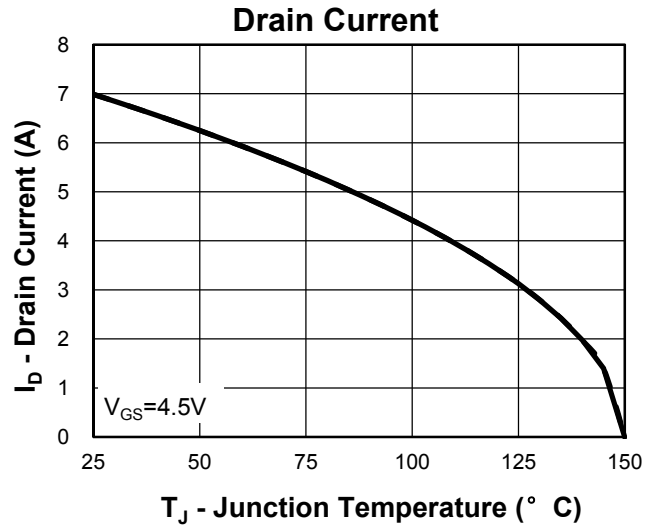
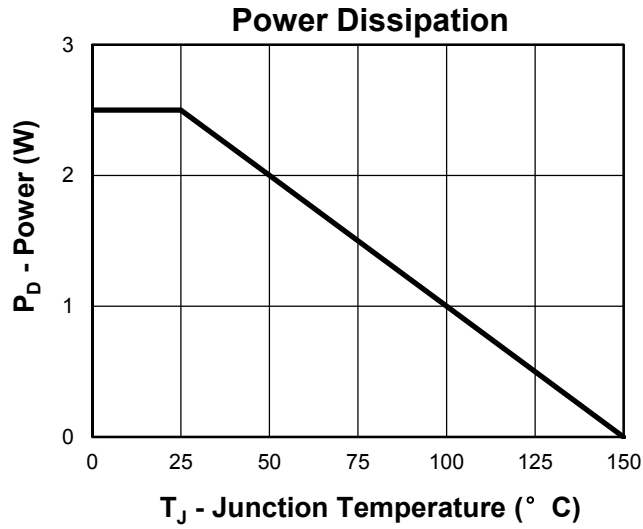

**Typical Characteristics**

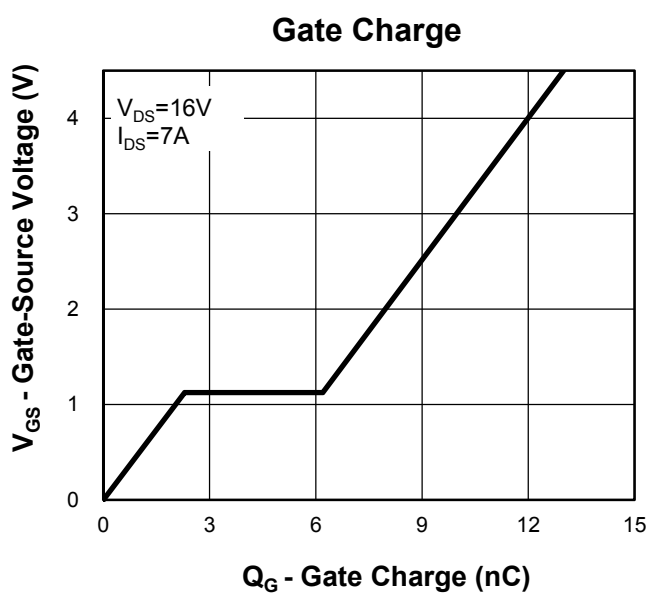
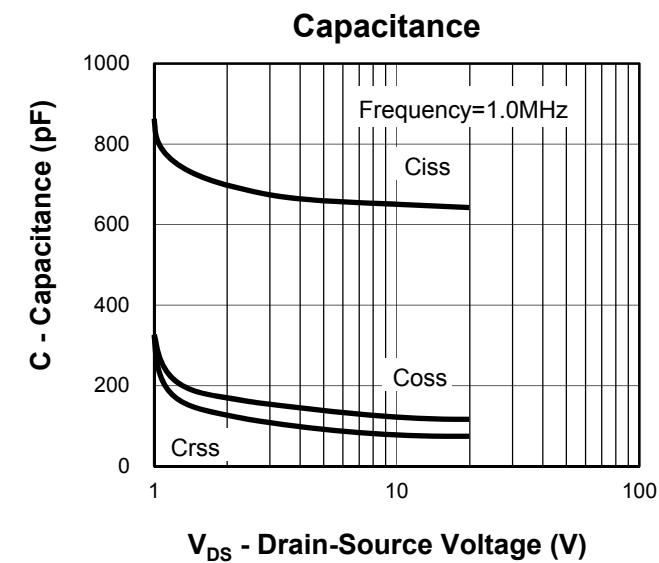
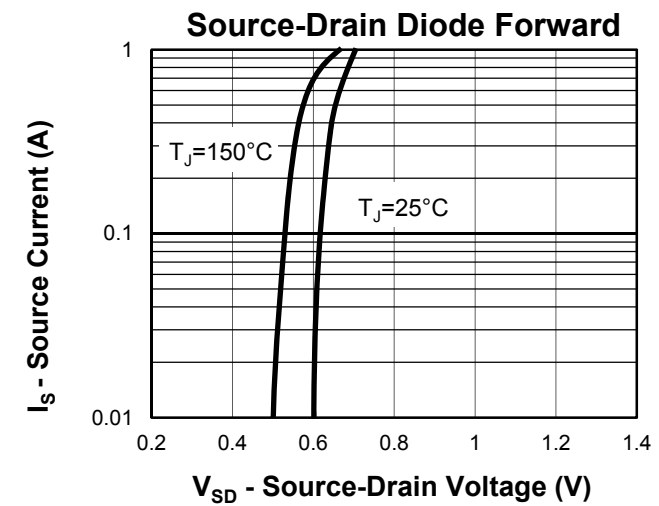
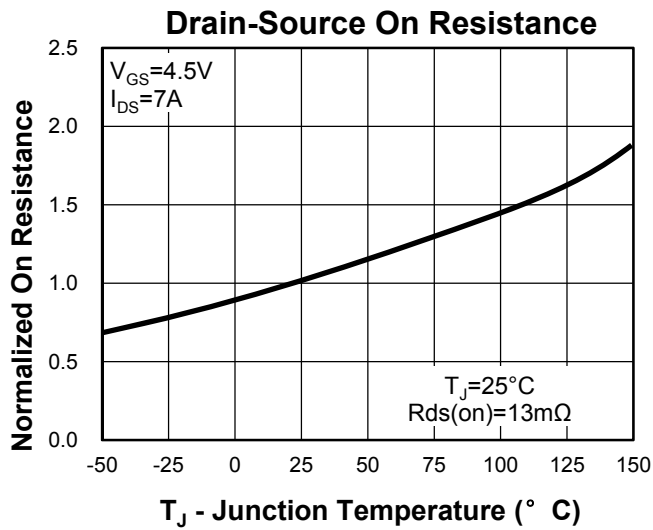
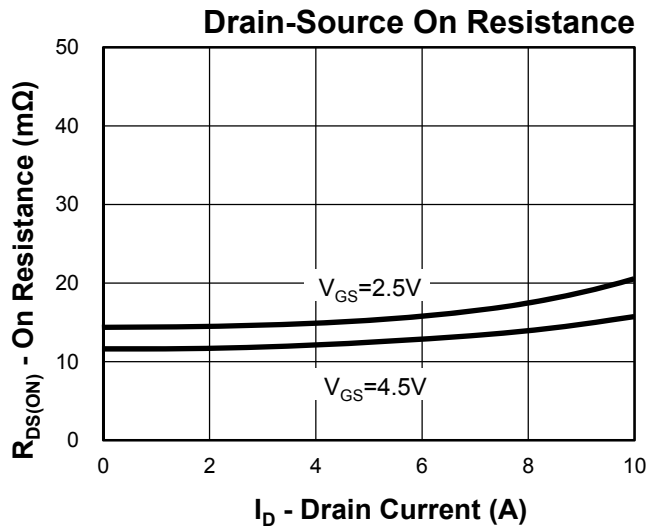
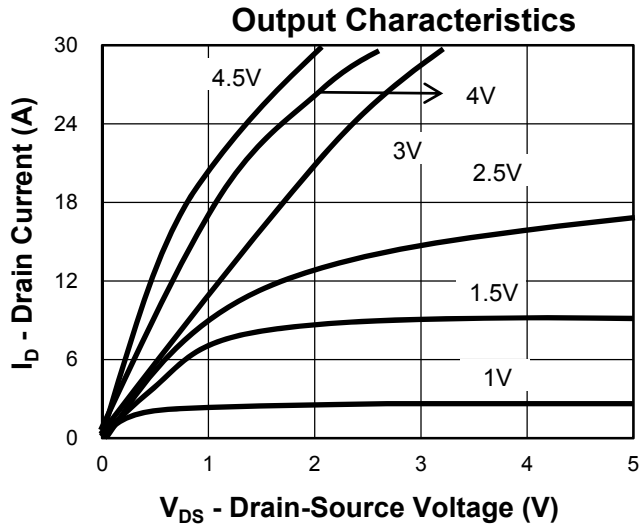

**Ordering and Marking Information**

Device	Marking	Package	Packaging	Quantity	Reel Size	Tape width
RU20D7H	RU20D7H	SOP-8	Tape&Reel	2500	13"	12mm

**Avalanche Test Circuit and Waveforms**

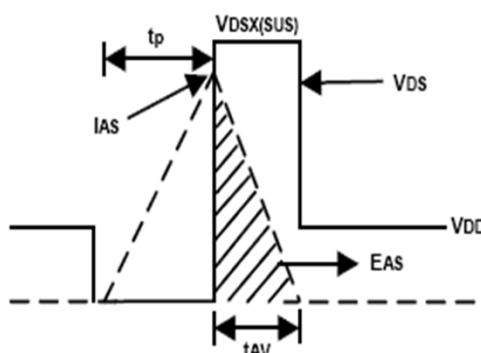
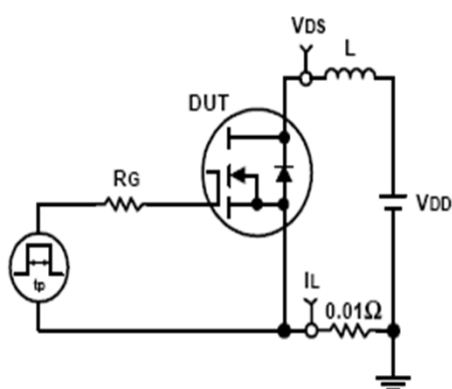

**Switching Time Test Circuit and Waveforms**

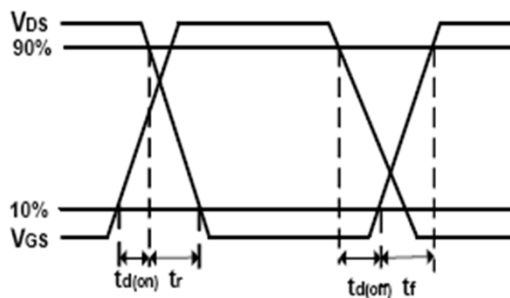
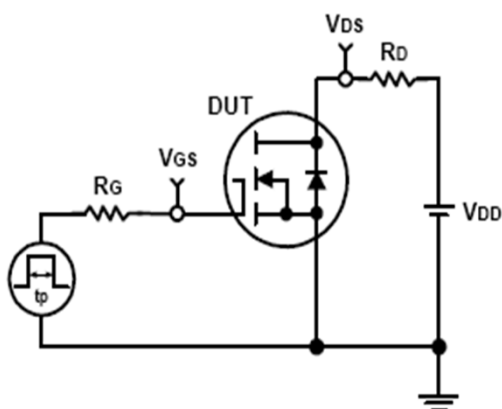

**Package Information**

**SOP-8**

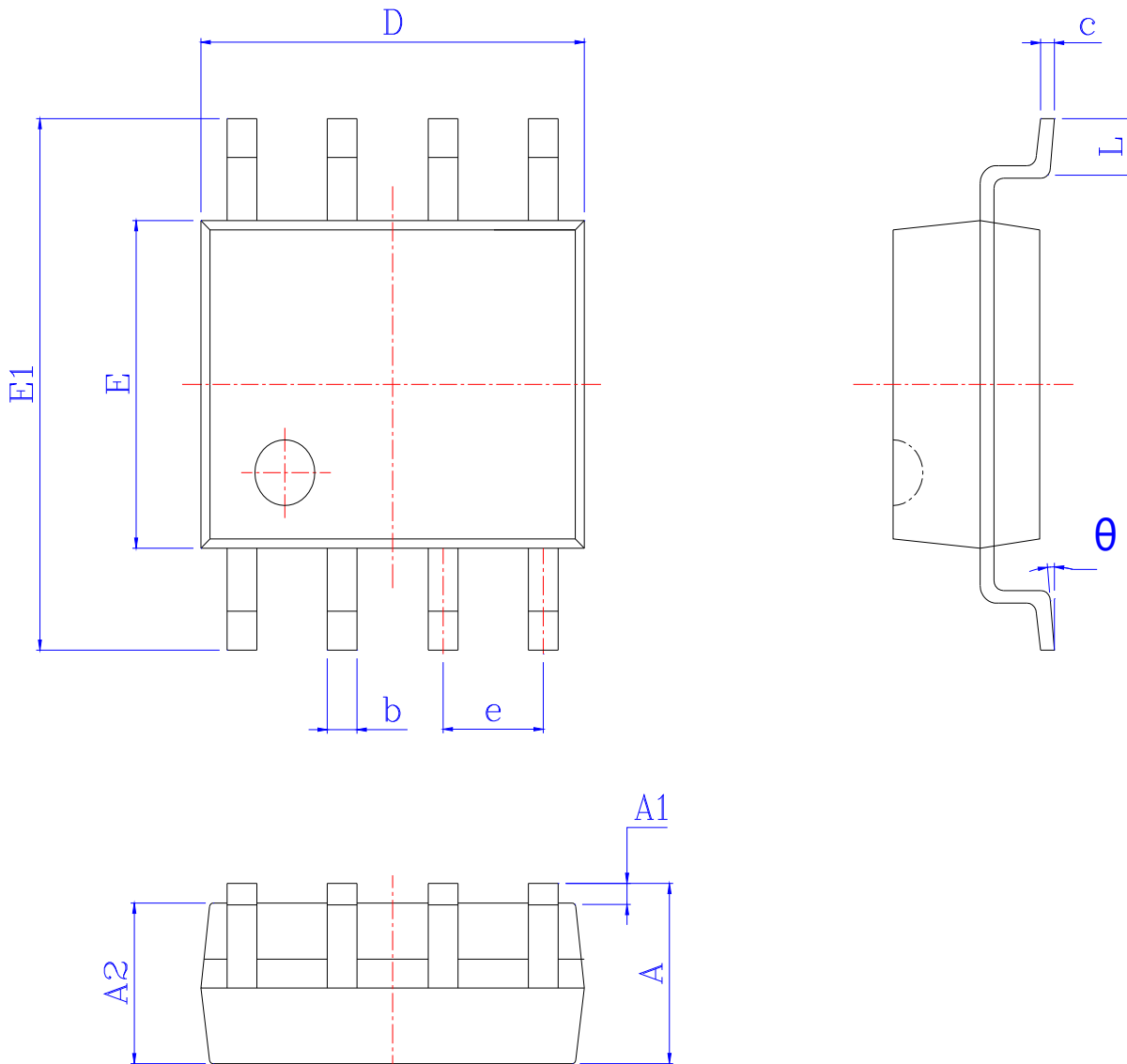

SYMBOL	MM			INCH		
	MIN	NOM	MAX	MIN	NOM	MAX
A	1.300	1.525	1.750	0.051	0.060	0.069
A1	0.050	0.150	0.250	0.002	0.006	0.010
A2	1.300	1.450	1.550	0.051	0.057	0.061
b	0.330	0.420	0.510	0.013	0.017	0.020
c	0.170	*	0.260	0.007	*	0.010
D	4.700	4.900	5.100	0.185	0.193	0.201
E	3.700	3.900	4.100	0.146	0.154	0.161
E1	5.800	6.000	6.200	0.228	0.236	0.244
e	1.270 BSC			0.050 BSC		
L	0.400	0.835	1.270	0.016	0.033	0.050
θ	0°	*	8°	0°	*	8°

**Customer Service****Worldwide Sales and Service:**

Sales@ruichips.com

**Technical Support:**

Technical@ruichips.com

**Investor Relations Contacts:**

Investor@ruichips.com

**Marcom Contact:**

Marcom@ruichips.com

**Editorial Contact:**

Editorial@ruichips.com

**HR Contact:**

HR@ruichips.com

**Legal Contact:**

Legal@ruichips.com

**Shen Zhen RUICHIPS Semiconductor CO., LTD**

4th Floor, Block 8, Changyuan New Material Port, Keyuan Middle Road, Science & Industry Park,  
Nanshan District, Shenzhen, CHINA

**TEL:** (86-755) 8311-5334**FAX:** (86-755) 8311-4278**E-mail:** Sales-SZ@ruichips.com