



N-channel 600V, 15A, 0.28Ω Super-Junction Power MOSFET

<p>Description</p> <p>Super-junction power MOSFET is a revolutionary technology for high voltage power MOSFET, designed according to the SJ principle. The resulting device has extremely low on resistance, making it especially suitable for applications which require superior power density and outstanding efficiency.</p> <p>Features</p> <ul style="list-style-type: none"> ◆ Very low FOM $R_{DS(on)} \times Q_g$ ◆ 100% UIS tested ◆ RoHS compliant <p>Applications</p> <ul style="list-style-type: none"> ◆ Power factor correction (PFC). ◆ Switched mode power supplies (SMPS). ◆ Uninterrupted power supply (UPS). 	<p>Product Summary</p> <table> <tr> <td>$V_{DS} @ T_{j,25^\circ C}$</td> <td>600V</td> </tr> <tr> <td>$R_{DS(on),max}$</td> <td>0.28Ω</td> </tr> <tr> <td>I_D</td> <td>15A</td> </tr> <tr> <td>$Q_{g,typ}$</td> <td>26 nC</td> </tr> </table> <div style="display: flex; justify-content: space-around; align-items: center;"> <div style="text-align: center;">  <p>TO-252</p> </div> <div style="text-align: center;">  <p>TO-251</p> </div> <div style="text-align: center;">  <p>TO-220F</p> </div> </div> <div style="text-align: center; margin-top: 20px;">  <p>N-Channel MOSFET</p> </div>	$V_{DS} @ T_{j,25^\circ C}$	600V	$R_{DS(on),max}$	0.28Ω	I_D	15A	$Q_{g,typ}$	26 nC
$V_{DS} @ T_{j,25^\circ C}$	600V								
$R_{DS(on),max}$	0.28Ω								
I_D	15A								
$Q_{g,typ}$	26 nC								

Marking information

Product	Package	Marking	Packing method
RMA60R280SN	TO-252	RMA60R280SN	Reel
RMG60R280SN	TO-251	RMG60R280SN	Tube
RMC60R280SN	TO-220F	RMC60R280SN	Tube

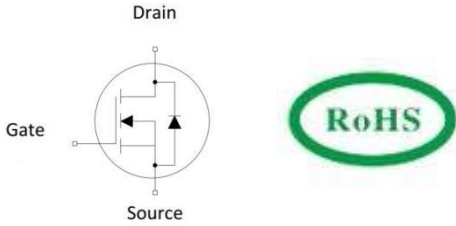
Absolute Maximum Ratings

Parameter	Symbol	Value	Unit
Drain-Source Voltage	V_{DSS}	600	V
Continuous drain current ($T_C = 25^\circ C$)	I_D	15	A
($T_C = 100^\circ C$)		9	A
Pulsed drain current ¹⁾	I_{DM}	45	A
Gate-Source voltage	V_{GSS}	± 30	V
Avalanche energy, single pulse ²⁾	E_{AS}	320	mJ
Avalanche current, repetitive ³⁾	I_{AR}	2.2	A
Power Dissipation TO-252 /TO-251 ($T_C = 25^\circ C$)	P_D	132	W
- Derate above 25°C		1.06	W/°C
Power Dissipation TO-220F ($T_C = 25^\circ C$)	P_D	34	W
- Derate above 25°C		0.27	W/°C
Operating and Storage Temperature Range	T_J, T_{STG}	-55 to +150	°C
Continuous diode forward current	I_S	15	A

Diode pulse current	$I_{S,pulse}$	45	A
---------------------	---------------	----	---

Thermal Characteristics

Parameter	Symbol	Value		Unit
		TO252/TO-251	TO-220F	
Thermal Resistance, Junction-to-Case	$R_{\theta JC}$	0.93	3.4	°C/W
Thermal Resistance, Junction-to-Ambient	$R_{\theta JA}$	106	58	°C/W
Soldering temperature, wave soldering only allowed at leads. (1.6mm from case for 10s)	T_{sold}	260	260	°C

Electrical Characteristics $T_c = 25^\circ\text{C}$ unless otherwise noted

Parameter	Symbol	Test Condition	Min.	Typ.	Max.	Unit
Static characteristics						
Drain-source breakdown voltage	BV_{DSS}	$V_{GS}=0\text{ V}, I_D=250\mu\text{A}$	600	-	-	V
Gate threshold voltage	$V_{GS(th)}$	$V_{DS}=V_{GS}, I_D=250\mu\text{A}$	2.5		4.0	V
Drain cut-off current	I_{DSS}	$V_{DS}=600\text{ V}, V_{GS}=0\text{ V},$ $T_j = 25^\circ\text{C}$ $T_j = 125^\circ\text{C}$	- -	- 10	1	μA
Gate leakage current, Forward	I_{GSSF}	$V_{GS}=30\text{ V}, V_{DS}=0\text{ V}$	-	-	100	nA
Gate leakage current, Reverse	I_{GSSR}	$V_{GS}=-30\text{ V}, V_{DS}=0\text{ V}$	-	-	-100	nA
Drain-source on-state resistance	$R_{DS(on)}$	$V_{GS}=10\text{ V}, I_D=7.5\text{ A}$ $T_j = 25^\circ\text{C}$	- - -	0.24	0.28	Ω
Dynamic characteristics						
Input capacitance	C_{iss}	$V_{DS} = 100\text{ V}, V_{GS} = 0\text{ V},$ $f = 1\text{ MHz}$	-	1126	-	pF
Output capacitance	C_{oss}		-	41	-	
Reverse transfer capacitance	C_{rss}		-	2.4	-	
Turn-on delay time	$t_{d(on)}$	$V_{DD} = 400\text{ V}, I_D = 7.5\text{ A}$ $R_G = 25\Omega, V_{GS}=10\text{ V}$	-	20	-	ns
Rise time	t_r		-	40	-	
Turn-off delay time	$t_{d(off)}$		-	95	-	
Fall time	t_f		-	43	-	
Gate charge characteristics						
Gate to source charge	Q_{gs}	$V_{DD}=480\text{ V}, I_D=7.5\text{ A},$ $V_{GS}=0\text{ to }10\text{ V}$	-	3.6	-	nC
Gate to drain charge	Q_{gd}		-	10.5	-	
Gate charge total	Q_g		-	26	-	
Gate plateau voltage	$V_{plateau}$		-	5.5	-	V
Reverse diode characteristics						
Diode forward voltage	V_{SD}	$V_{GS}=0\text{ V}, I_F=7.5\text{ A}$	-	0.85	-	V
Reverse recovery time	t_{rr}	$V_R=400\text{ V}, I_F=7.5\text{ A},$ $dI_F/dt=100\text{ A}/\mu\text{s}$	-	405	-	ns
Reverse recovery charge	Q_{rr}		-	4.0	-	μC
Peak reverse recovery current	I_{rrm}		-	21	-	A

Notes:

1. Limited by maximum junction temperature, maximum duty cycle is 0.75.
2. $I_{AS} = 4A$, $V_{DD} = 50V$, Starting $T_j = 25^{\circ}C$.

Electrical Characteristics Diagrams

Figure 1. Output Characteristics

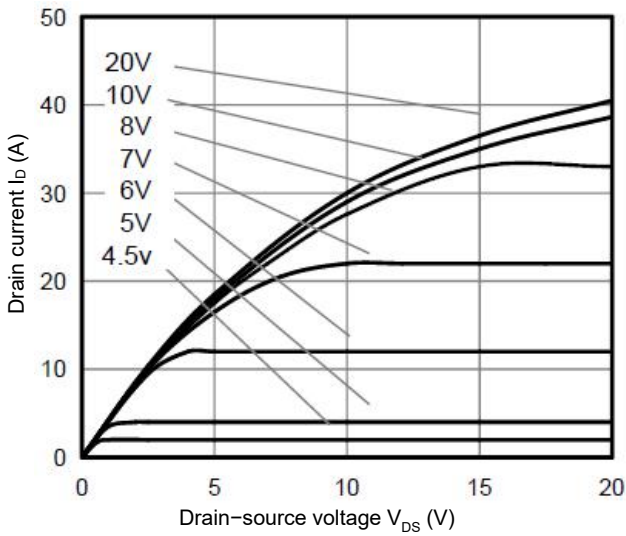

Figure 2. Transfer Characteristics

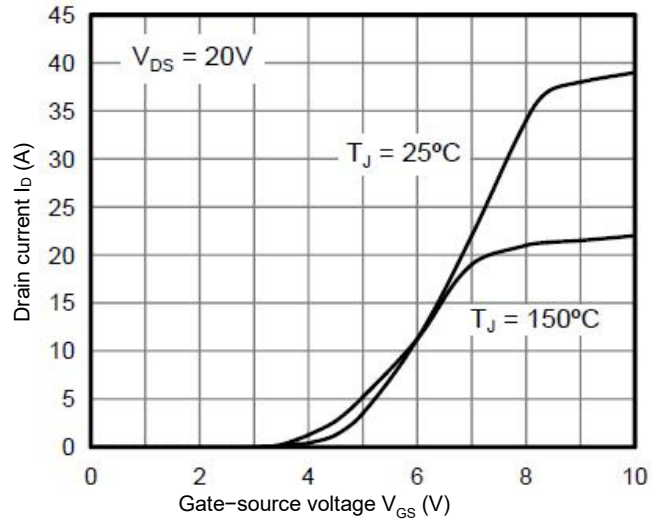

Figure 3. On-Resistance vs. Drain Current

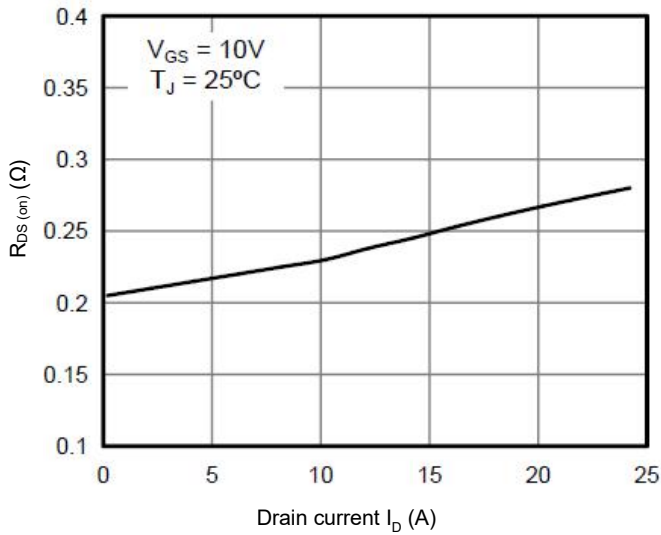

Figure 4. Capacitance Characteristics

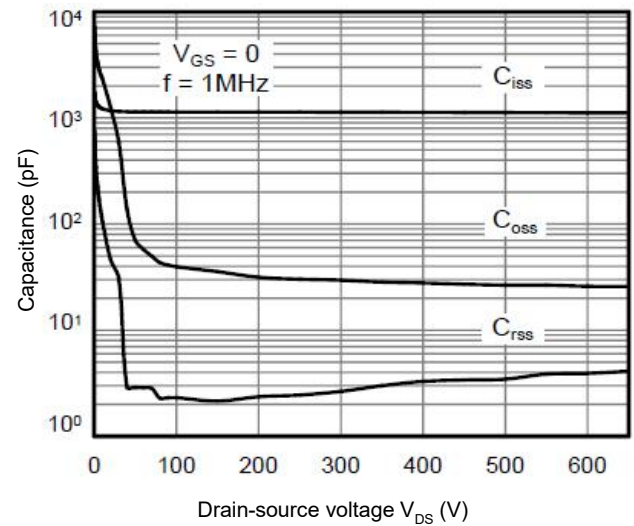

Figure 5. Gate Charge Characteristics

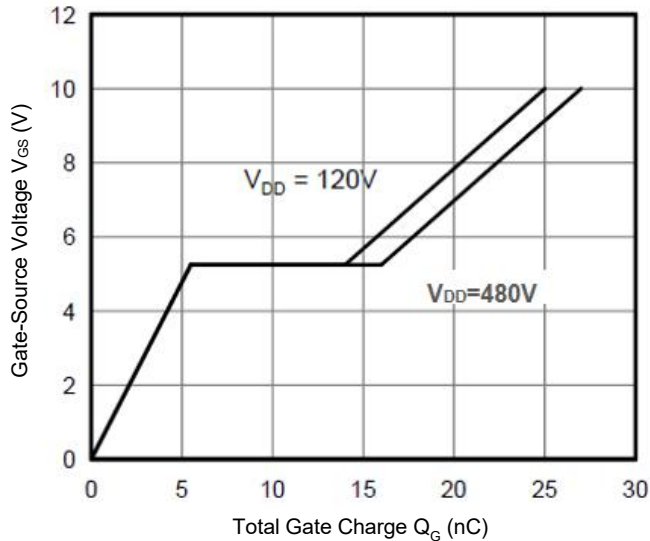

Figure 6. Body Diode Forward Voltage

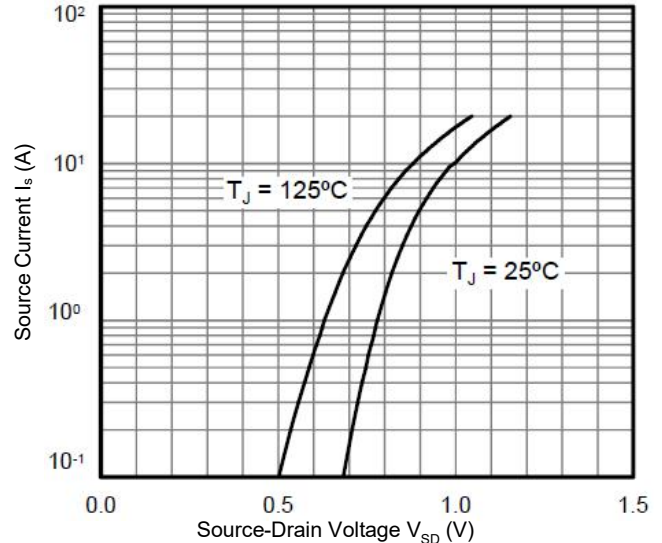

Figure 7. Breakdown Voltage vs. Temperature

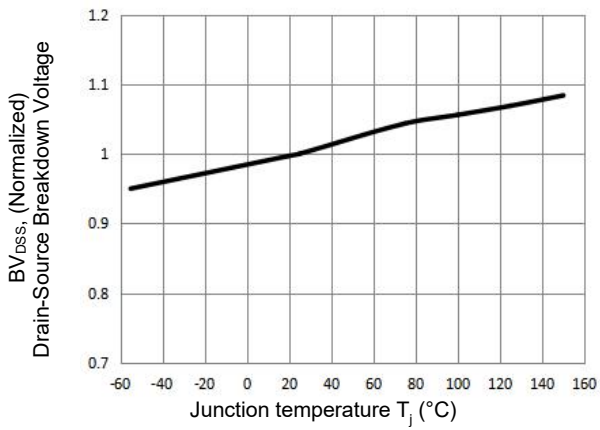

Figure 8. On-Resistance vs. Temperature

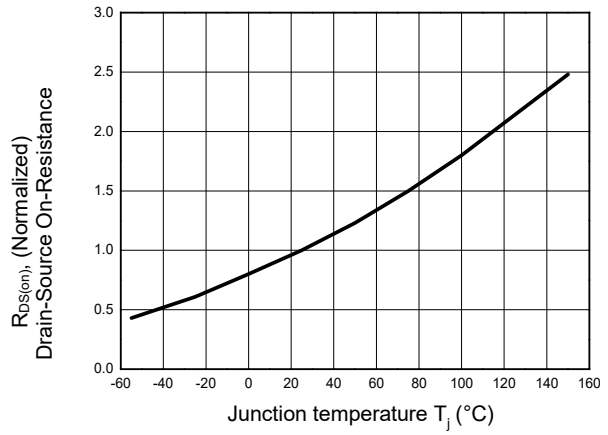

Figure 9. Maximum Safe Operating Area
TO-252/TO-251

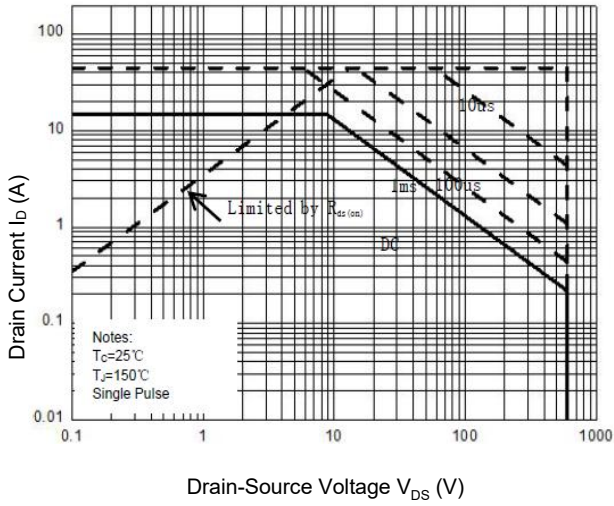
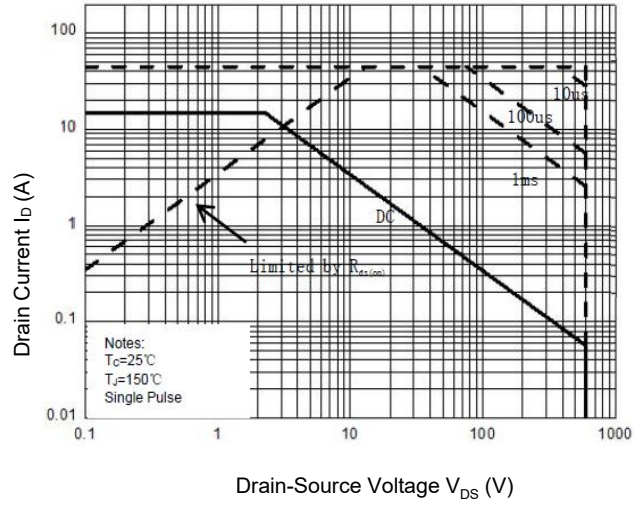
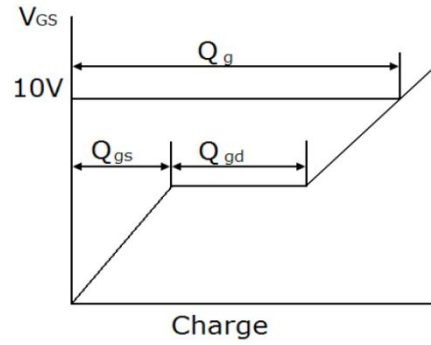
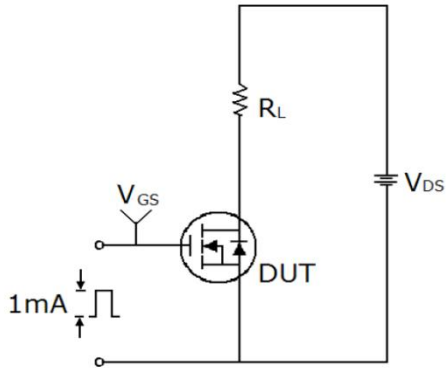

Figure 10. Maximum Safe Operating Area
TO-220F



Test Circuits

Gate Charge Test Circuit & Waveform



Switching Test Circuit & Waveform

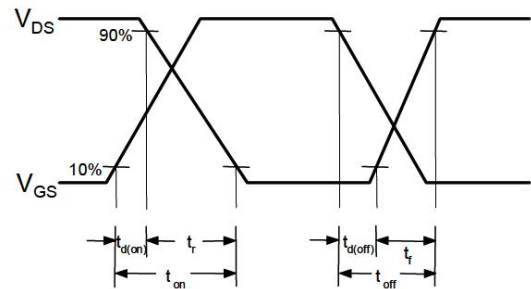
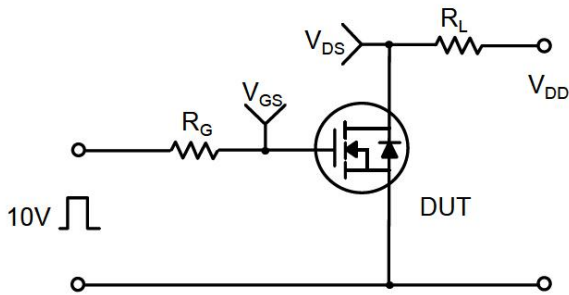

Unclamped Inductive Switching Test Circuit & Waveform

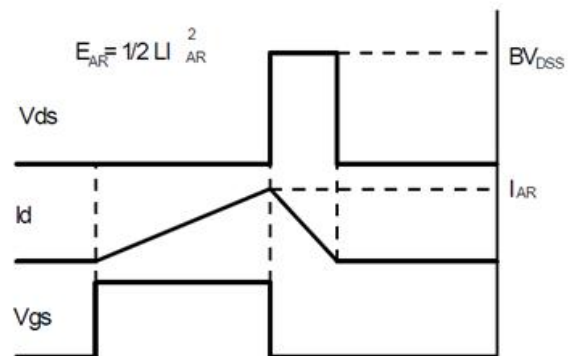
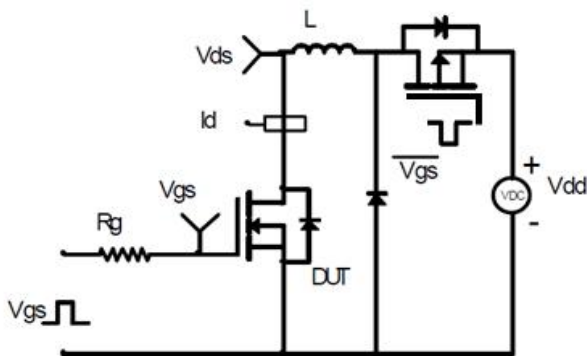

Mechanical Dimensions for TO-252

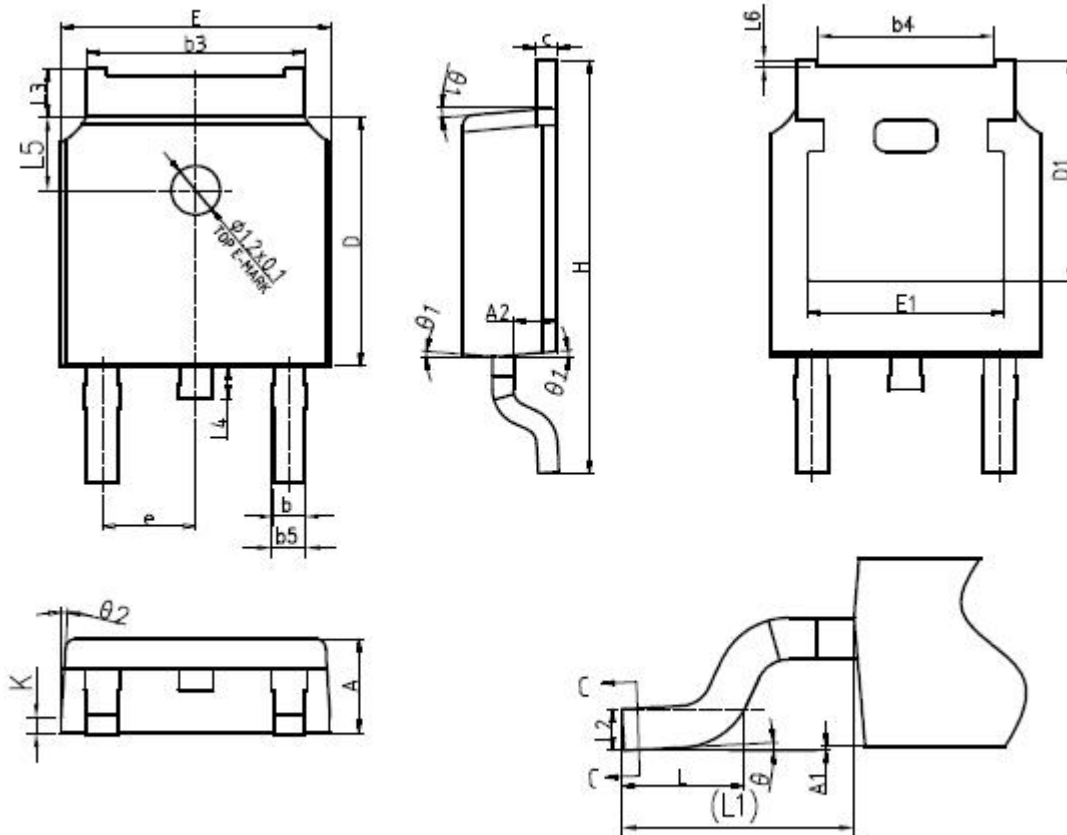

单位: mm

SYMBOL	mm		
	MIN	NOM	MAX
*A	2.20	2.30	2.38
*A1	0.00	-	0.10
A2	0.97	1.07	1.17
*b	0.72	0.78	0.85
b1	0.71	0.76	0.81
*b3	5.23	5.33	5.46
b4	4.27	4.32	4.37
b5	0.72	0.88	0.93
*c	0.47	0.53	0.58
c1	0.46	0.51	0.56
*D	6.00	6.10	6.20
D1	5.30REF		

*E	6.50	6.60	6.70
E1	4.70	4.83	4.92
*e	2.286BSC		
L	1.40	1.50	1.70
L1	2.90REF		
L2	0.51BSC		
*L3	0.90	-	1.25
*L4	0.60	0.80	1.00
L5	1.70	1.80	1.90
L6	0	0.047	0.123
θ	0°	-	8°
* $\theta 1$	5°	7°	9°
$\theta 2$	5°	7°	9°
K	0.40REF		

Mechanical Dimensions for TO-251



SYMBOL	MM		
	MIN	NOM	MAX
*A	2.20	2.30	2.38
*A2	0.97	1.07	1.17
*b	0.72	0.78	0.85
b1	0.71	0.76	0.81
*b2	0.72	0.88	0.95
*b3	5.23	5.33	5.46
*c	0.47	0.53	0.58
c1	0.46	0.51	0.56
*D	6.00	6.10	6.20
D1	5.30REF		
*E	6.50	6.60	6.70
E1	4.70	4.83	4.92
*e	2.286BSC		
*L1	9.20	9.40	9.60
L2	1.25	1.35	1.45
*L3	0.90	1.02	1.25
L5	1.70	1.80	1.90
* $\theta 1$	5°	7°	9°
$\theta 2$	5°	7°	9°
$\theta 3$	11°	13°	15°
K	0.40REF		

Mechanical Dimensions for TO-220F

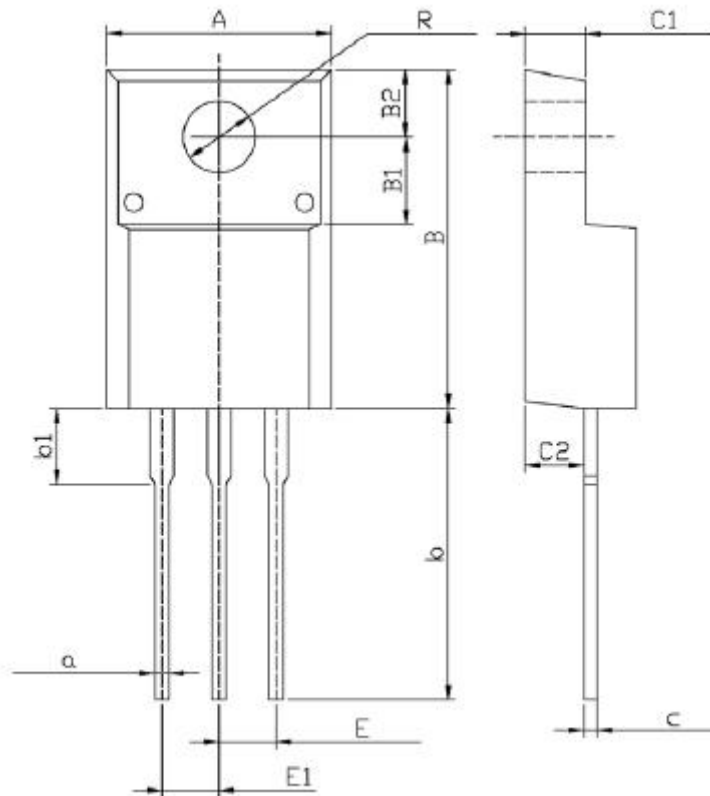

Symbol	Dimensions In Millimeters		Symbol	Dimensions In Millimeters	
	Min	Max		Min	Max
C	4.3	4.7	b1	2.9	3.9
A	9.7	10.3	a	0.55	0.75
B	14.7	15.3	E	2.29	2.79
B1	3.8	4.0	E1	2.29	2.79
B2	2.9	3.1	C1	2.5	2.9
R	3.0	3.4	C2	2.5	2.7
b	12.5	13.5	c	0.5	0.7