



## N-channel 500V, 4A, 1.0Ω Super-Junction Power MOSFET

<p><b>Description</b></p> <p>Super-junction power MOSFET is a revolutionary technology for high voltage power MOSFET , designed according to the SJ principle. The resulting device has extremely low on resistance,making it especially suitable for applications which require superior power density and outstanding efficiency.</p> <p><b>Features</b></p> <ul style="list-style-type: none"> <li>◆ Very low FOM <math>R_{DS(on)} \times Q_g</math></li> <li>◆ 100% UIS tested</li> <li>◆ RoHS compliant</li> </ul> <p><b>Applications</b></p> <ul style="list-style-type: none"> <li>◆ Power factor correction (PFC).</li> <li>◆ Switched mode power supplies (SMPS).</li> <li>◆ Uninterrupted power supply (UPS).</li> </ul>	<p><b>Product Summary</b></p> <table> <tr> <td><math>V_{DS} @ T_{j,25^\circ C}</math></td> <td>500V</td> </tr> <tr> <td><math>R_{DS(on),typ}</math></td> <td>1.0Ω</td> </tr> <tr> <td><math>I_D</math></td> <td>4.0A</td> </tr> <tr> <td><math>Q_{g,typ}</math></td> <td>9.0 nC</td> </tr> </table> <div style="display: flex; justify-content: space-around; align-items: center;"> <div style="text-align: center;">  <p>TO-252</p> </div> <div style="text-align: center;">  <p>TO-251</p> </div> <div style="text-align: center;">  <p>TO-220F</p> </div> </div> <div style="text-align: center; margin-top: 20px;">  <p>N-Channel MOSFET</p> </div>	$V_{DS} @ T_{j,25^\circ C}$	500V	$R_{DS(on),typ}$	1.0Ω	$I_D$	4.0A	$Q_{g,typ}$	9.0 nC
$V_{DS} @ T_{j,25^\circ C}$	500V								
$R_{DS(on),typ}$	1.0Ω								
$I_D$	4.0A								
$Q_{g,typ}$	9.0 nC								

### Marking information

Product	Package	Marking	Packing method
RMA50R1K0SN	TO-252	RMA50R1K0SN	Reel
RMG50R1K0SN	TO-251	RMG50R1K0SN	Tube
RMC50R1K0SN	TO-220F	RMC50R1K0SN	Tube

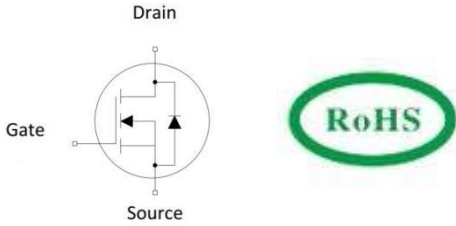
### Absolute Maximum Ratings

Parameter	Symbol	Value	Unit
Drain-Source Voltage	$V_{DSS}$	500	V
Continuous drain current ( $T_C = 25^\circ C$ )	$I_D$	4	A
( $T_C = 100^\circ C$ )		2.5	A
Pulsed drain current <sup>1)</sup>	$I_{DM}$	12	A
Gate-Source voltage	$V_{GSS}$	$\pm 30$	V
Avalanche energy, single pulse <sup>2)</sup>	$E_{AS}$	50	mJ
Avalanche current, repetitive <sup>3)</sup>	$I_{AR}$	0.9	A
Power Dissipation TO-252 /TO-251 ( $T_C = 25^\circ C$ )	$P_D$	37	W
- Derate above 25°C		0.3	W/°C
Power Dissipation TO-220F ( $T_C = 25^\circ C$ )	$P_D$	30	W
- Derate above 25°C		0.24	W/°C
Operating and Storage Temperature Range	$T_J, T_{STG}$	-55 to +150	°C
Continuous diode forward current	$I_S$	4	A

Diode pulse current	$I_{S,pulse}$	12	A
---------------------	---------------	----	---

### Thermal Characteristics

Parameter	Symbol	Value		Unit
		TO252/TO-251	TO-220F	
Thermal Resistance, Junction-to-Case	$R_{\theta JC}$	2.8	4.4	$^{\circ}\text{C/W}$
Thermal Resistance, Junction-to-Ambient	$R_{\theta JA}$	62	73	$^{\circ}\text{C/W}$
Soldering temperature, wave soldering only allowed at leads. (1.6mm from case for 10s)	$T_{sold}$	260	260	$^{\circ}\text{C}$

### Electrical Characteristics $T_c = 25^{\circ}\text{C}$ unless otherwise noted

Parameter	Symbol	Test Condition	Min.	Typ.	Max.	Unit
<b>Static characteristics</b>						
Drain-source breakdown voltage	$BV_{DSS}$	$V_{GS}=0\text{ V}, I_D=250\mu\text{A}$	500	-	-	V
Gate threshold voltage	$V_{GS(th)}$	$V_{DS}=V_{GS}, I_D=250\mu\text{A}$	2.5		4.0	V
Drain cut-off current	$I_{DSS}$	$V_{DS}=500\text{ V}, V_{GS}=0\text{ V},$ $T_j = 25^{\circ}\text{C}$ $T_j = 125^{\circ}\text{C}$	-	-	1	$\mu\text{A}$
Gate leakage current, Forward	$I_{GSSF}$	$V_{GS}=30\text{ V}, V_{DS}=0\text{ V}$	-	-	100	nA
Gate leakage current, Reverse	$I_{GSSR}$	$V_{GS}=-30\text{ V}, V_{DS}=0\text{ V}$	-	-	-100	nA
Drain-source on-state resistance	$R_{DS(on)}$	$V_{GS}=10\text{ V}, I_D=2\text{ A}$ $T_j = 25^{\circ}\text{C}$	-	1.0	1.2	$\Omega$
<b>Dynamic characteristics</b>						
Input capacitance	$C_{iss}$	$V_{DS} = 100\text{ V}, V_{GS} = 0\text{ V},$ $f = 1\text{ MHz}$	-	315	-	pF
Output capacitance	$C_{oss}$		-	27	-	
Reverse transfer capacitance	$C_{rss}$		-	1.2	-	
Turn-on delay time	$t_{d(on)}$	$V_{DD} = 400\text{ V}, I_D = 2\text{ A}$ $R_G = 25\Omega, V_{GS}=10\text{ V}$	-	9.4	-	ns
Rise time	$t_r$		-	22.6	-	
Turn-off delay time	$t_{d(off)}$		-	36.4	-	
Fall time	$t_f$		-	25.4	-	
<b>Gate charge characteristics</b>						
Gate to source charge	$Q_{gs}$	$V_{DD}=480\text{ V}, I_D=2\text{ A},$ $V_{GS}=0\text{ to }10\text{ V}$	-	2.1	-	nC
Gate to drain charge	$Q_{gd}$		-	3.8	-	
Gate charge total	$Q_g$		-	9.0	-	
Gate plateau voltage	$V_{plateau}$		-	5.5	-	V
<b>Reverse diode characteristics</b>						
Diode forward voltage	$V_{SD}$	$V_{GS}=0\text{ V}, I_F=2\text{ A}$	-	0.85	-	V
Reverse recovery time	$t_{rr}$	$V_R=50\text{ V}, I_F=2\text{ A},$ $dI_F/dt=100\text{ A}/\mu\text{s}$	-	159	-	ns
Reverse recovery charge	$Q_{rr}$		-	0.93	-	$\mu\text{C}$
Peak reverse recovery current	$I_{rrm}$		-	11.2	-	A

## Notes:

1. Limited by maximum junction temperature, maximum duty cycle is 0.75.
2.  $I_{AS} = 1A$ ,  $V_{DD} = 50V$ , Starting  $T_j = 25^{\circ}C$ .

**Electrical Characteristics Diagrams**

Figure 1. Output Characteristics

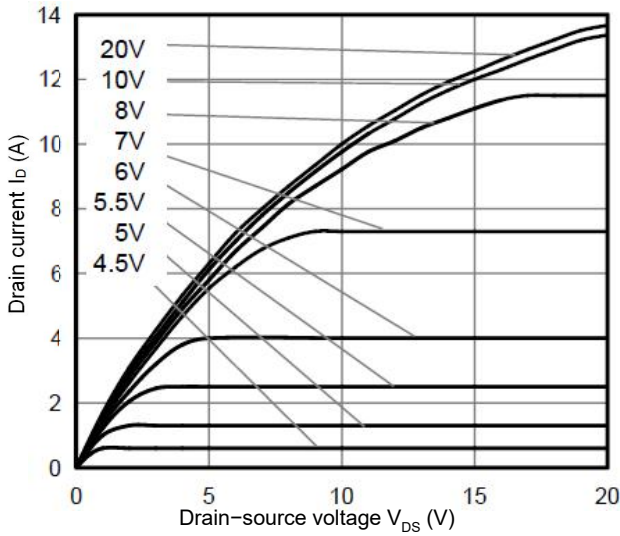

Figure 2. Transfer Characteristics

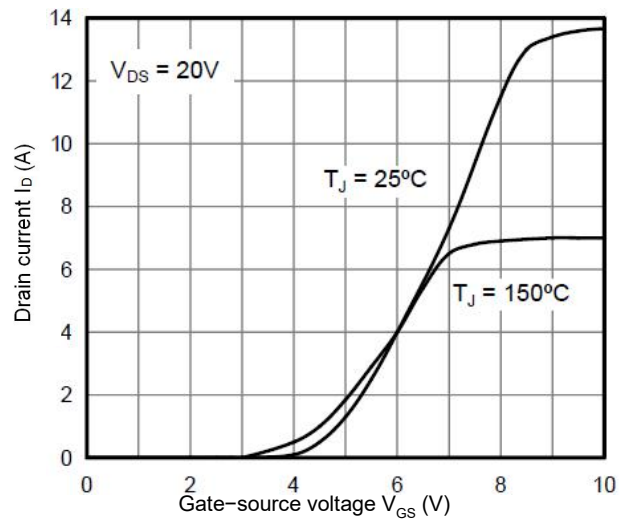

Figure 3. On-Resistance vs. Drain Current

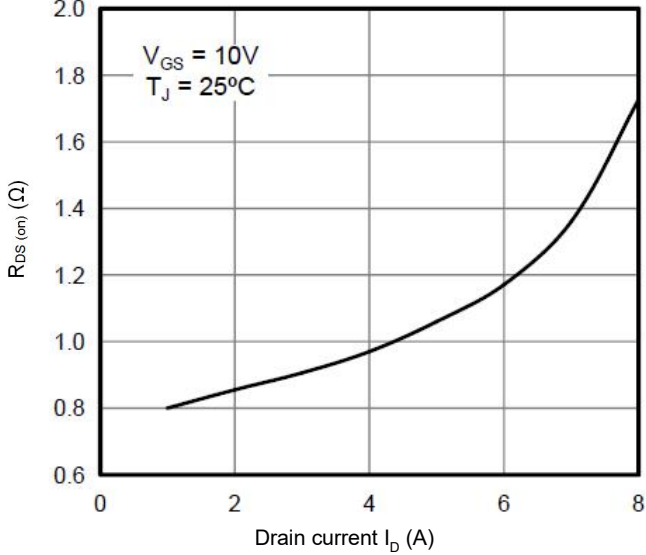

Figure 4. Capacitance Characteristics

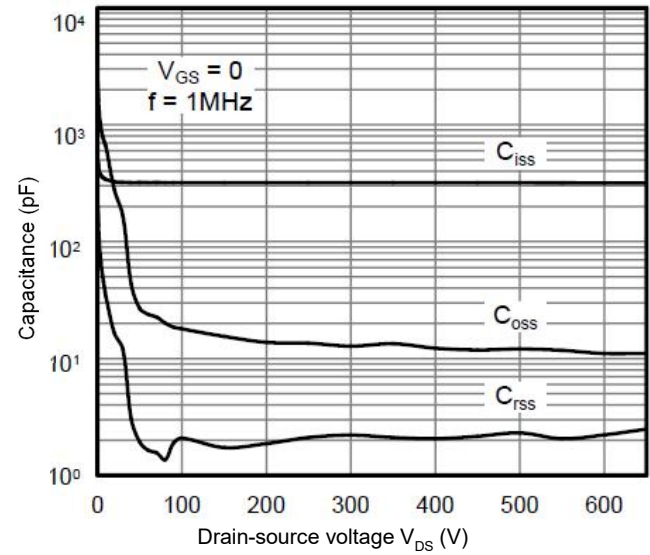

Figure 5. Gate Charge Characteristics

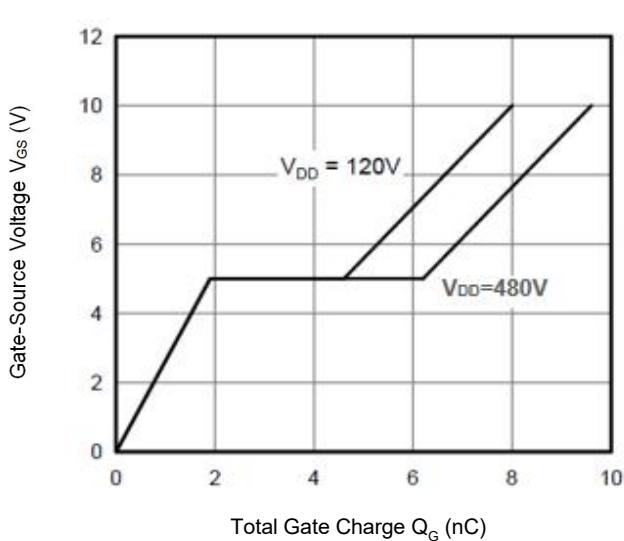

Figure 6. Body Diode Forward Voltage

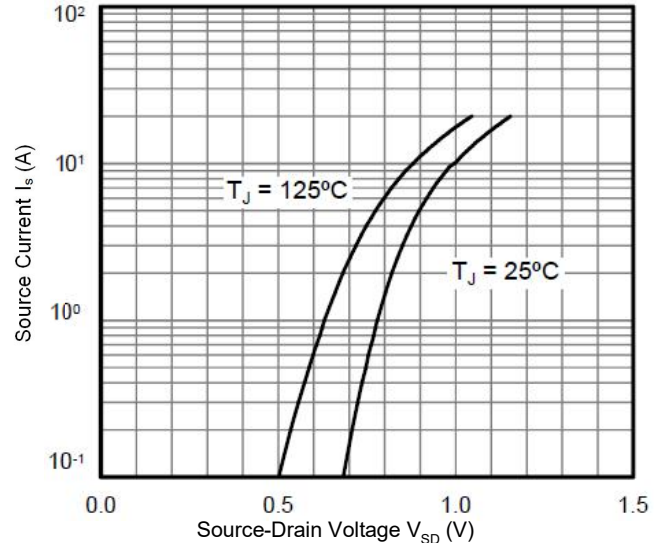

Figure 7. Breakdown Voltage vs. Temperature

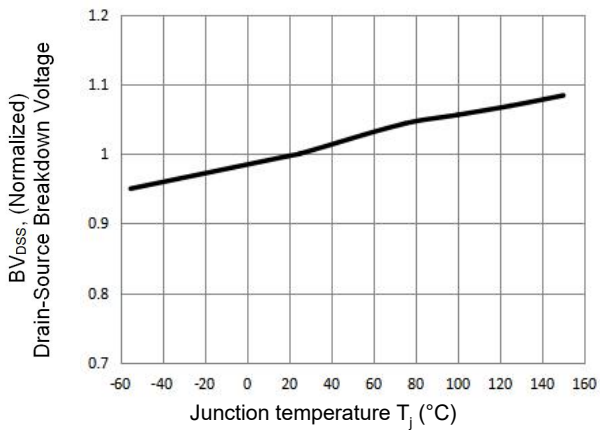

Figure 8. On-Resistance vs. Temperature

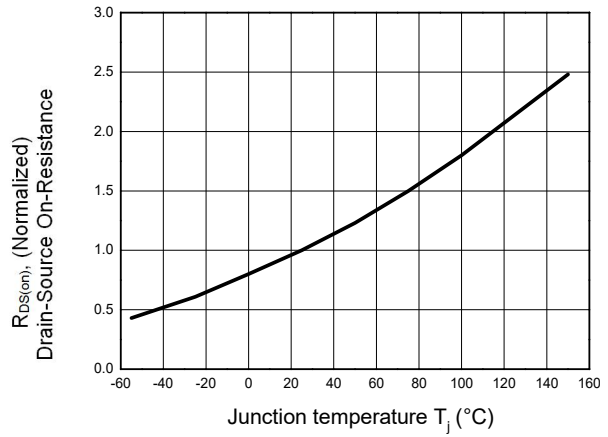

Figure 9. Maximum Safe Operating Area  
TO-252/TO-251

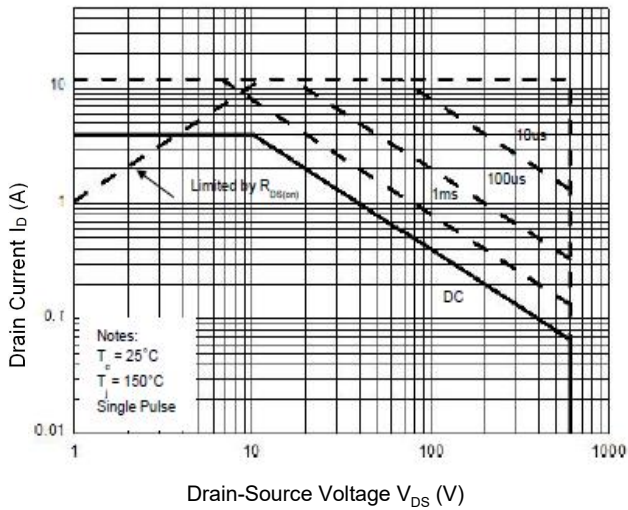
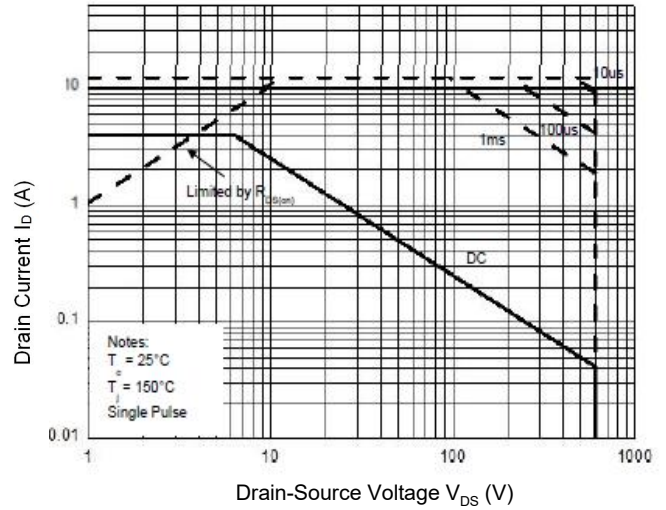
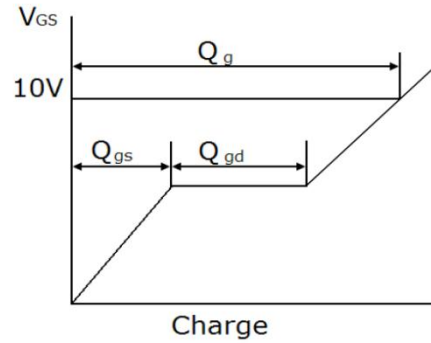
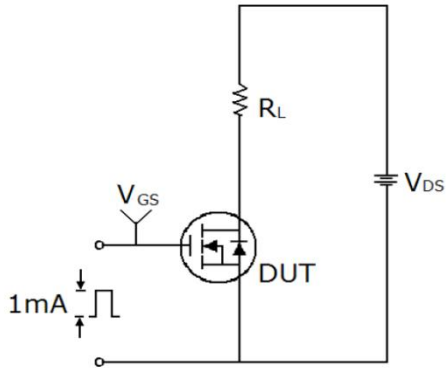

Figure 10. Maximum Safe Operating Area  
TO-220F



**Test Circuits**

**Gate Charge Test Circuit & Waveform**



**Switching Test Circuit & Waveform**

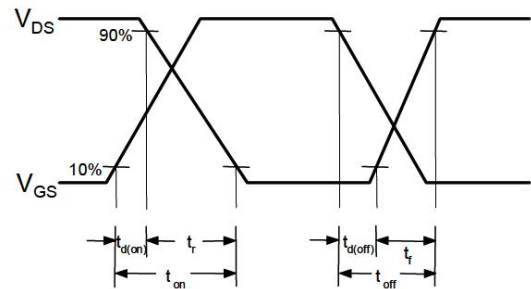
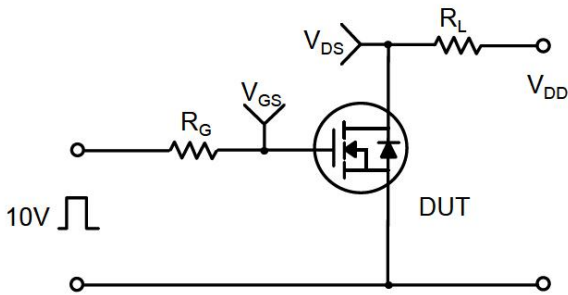

**Unclamped Inductive Switching Test Circuit & Waveform**

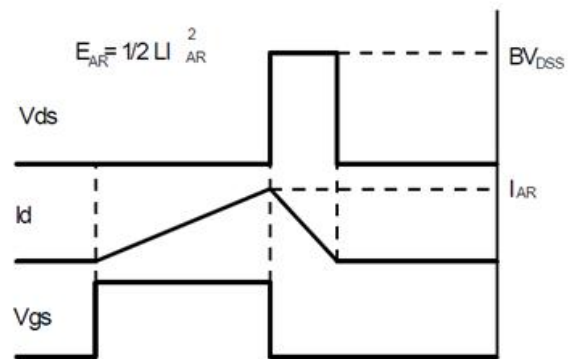
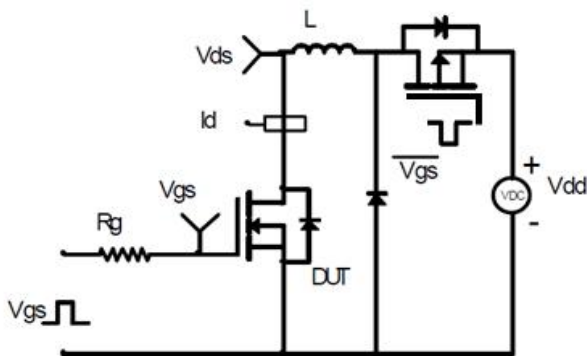

Mechanical Dimensions for TO-252

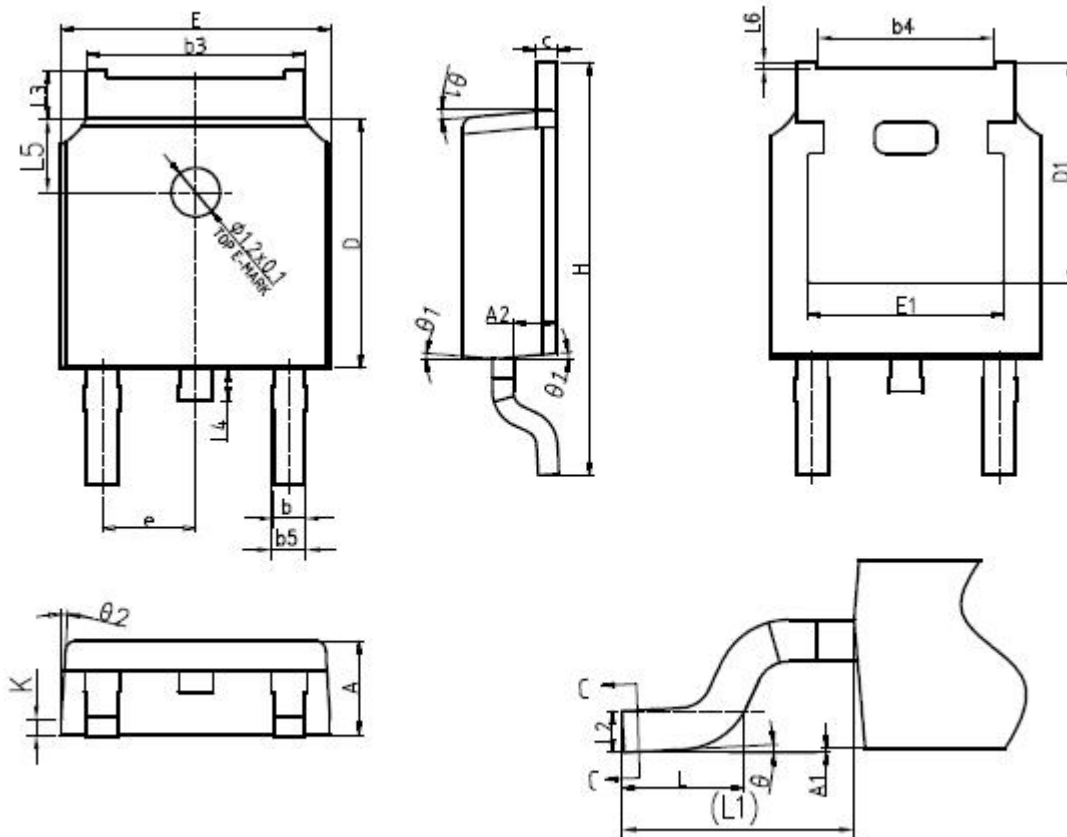

单位: mm

SYMBOL	mm		
	MIN	NOM	MAX
*A	2.20	2.30	2.38
*A1	0.00	-	0.10
A2	0.97	1.07	1.17
*b	0.72	0.78	0.85
b1	0.71	0.76	0.81
*b3	5.23	5.33	5.46
b4	4.27	4.32	4.37
b5	0.72	0.88	0.93
*c	0.47	0.53	0.58
c1	0.46	0.51	0.56
*D	6.00	6.10	6.20
D1	5.30REF		

*E	6.50	6.60	6.70
E1	4.70	4.83	4.92
*e	2.286BSC		
L	1.40	1.50	1.70
L1	2.90REF		
L2	0.51BSC		
*L3	0.90	-	1.25
*L4	0.60	0.80	1.00
L5	1.70	1.80	1.90
L6	0	0.047	0.123
$\theta$	0°	-	8°
* $\theta 1$	5°	7°	9°
$\theta 2$	5°	7°	9°
K	0.40REF		

Mechanical Dimensions for TO-251



SYMBOL	MM		
	MIN	NOM	MAX
*A	2.20	2.30	2.38
*A2	0.97	1.07	1.17
*b	0.72	0.78	0.85
b1	0.71	0.76	0.81
*b2	0.72	0.88	0.95
*b3	5.23	5.33	5.46
*c	0.47	0.53	0.58
c1	0.46	0.51	0.56
*D	6.00	6.10	6.20
D1	5.30REF		
*E	6.50	6.60	6.70
E1	4.70	4.83	4.92
*e	2.286BSC		
*L1	9.20	9.40	9.60
L2	1.25	1.35	1.45
*L3	0.90	1.02	1.25
L5	1.70	1.80	1.90
* $\theta 1$	5°	7°	9°
$\theta 2$	5°	7°	9°
$\theta 3$	11°	13°	15°
K	0.40REF		

Mechanical Dimensions for TO-220F

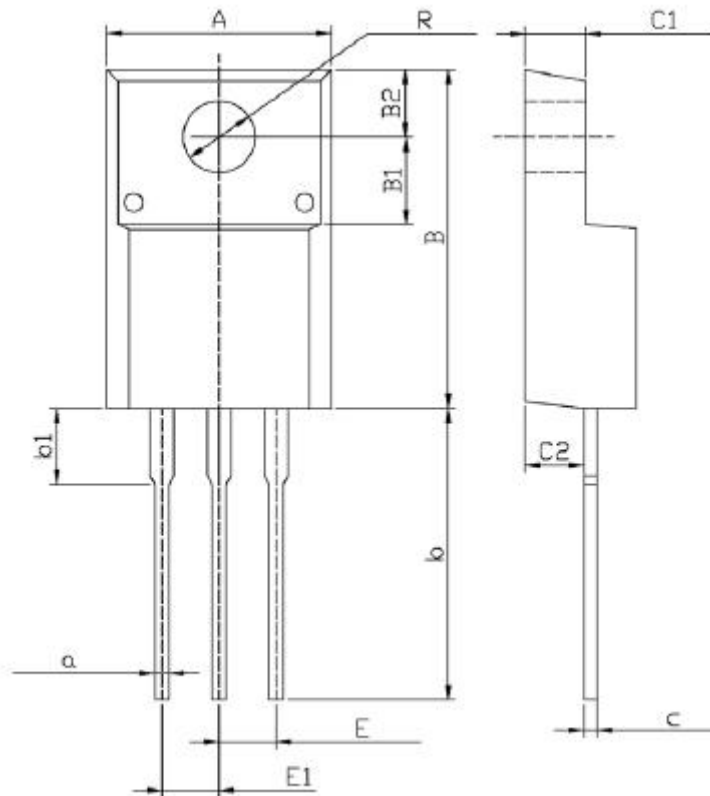

Symbol	Dimensions In Millimeters		Symbol	Dimensions In Millimeters	
	Min	Max		Min	Max
C	4.3	4.7	b1	2.9	3.9
A	9.7	10.3	a	0.55	0.75
B	14.7	15.3	E	2.29	2.79
B1	3.8	4.0	E1	2.29	2.79
B2	2.9	3.1	C1	2.5	2.9
R	3.0	3.4	C2	2.5	2.7
b	12.5	13.5	c	0.5	0.7