



N-channel 650V, 7A, 0.60Ω Super-Junction Power MOSFET

<p>Description</p> <p>Super-junction power MOSFET is a revolutionary technology for high voltage power MOSFET, designed according to the SJ principle. The resulting device has extremely low on resistance, making it especially suitable for applications which require superior power density and outstanding efficiency.</p> <p>Features</p> <ul style="list-style-type: none"> ◆ Very low FOM $R_{DS(on)} \times Q_g$ ◆ 100% UIS tested ◆ RoHS compliant <p>Applications</p> <ul style="list-style-type: none"> ◆ Power factor correction (PFC). ◆ Switched mode power supplies (SMPS). ◆ Uninterrupted power supply (UPS). 	<p>Product Summary</p> <table> <tr> <td>$V_{DS} @ T_{j,25^\circ C}$</td> <td>650V</td> </tr> <tr> <td>$R_{DS(on),max}$</td> <td>0.60Ω</td> </tr> <tr> <td>I_D</td> <td>7.0A</td> </tr> <tr> <td>$Q_{g,typ}$</td> <td>13.3 nC</td> </tr> </table> <div style="display: flex; justify-content: space-around; align-items: center;"> <div style="text-align: center;">  <p>TO-252</p> </div> <div style="text-align: center;">  <p>TO-251</p> </div> <div style="text-align: center;">  <p>TO-220F</p> </div> </div> <div style="text-align: center; margin-top: 20px;">  <p>N-Channel MOSFET</p> </div>	$V_{DS} @ T_{j,25^\circ C}$	650V	$R_{DS(on),max}$	0.60Ω	I_D	7.0A	$Q_{g,typ}$	13.3 nC
$V_{DS} @ T_{j,25^\circ C}$	650V								
$R_{DS(on),max}$	0.60Ω								
I_D	7.0A								
$Q_{g,typ}$	13.3 nC								

Marking information

Product	Package	Marking	Packing method
RMA65R600BN	TO-252	RMA65R600BN	Reel
RMG65R600BN	TO-251	RMG65R600BN	Tube
RMC65R600BN	TO-220F	RMC65R600BN	Tube

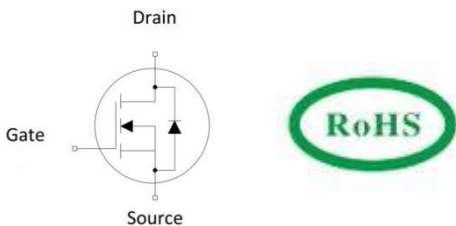
Absolute Maximum Ratings

Parameter	Symbol	Value	Unit
Drain-Source Voltage	V_{DSS}	650	V
Continuous drain current ($T_C = 25^\circ C$) ($T_C = 100^\circ C$)	I_D	7	A
		4.4	A
Pulsed drain current ¹⁾	I_{DM}	21	A
Gate-Source voltage	V_{GSS}	± 30	V
Avalanche energy, single pulse ²⁾	E_{AS}	120	mJ
Avalanche current, repetitive ³⁾	I_{AR}	1.2	A
Power Dissipation TO-252 /TO-251 ($T_C = 25^\circ C$) - Derate above 25°C	P_D	63	W
		0.5	W/°C
Power Dissipation TO-220F ($T_C = 25^\circ C$) - Derate above 25°C	P_D	32	W
		0.26	W/°C
Operating and Storage Temperature Range	T_J, T_{STG}	-55 to +150	°C
Continuous diode forward current	I_S	7	A
Diode pulse current	$I_{S,pulse}$	21	A

Thermal Characteristics

Parameter	Symbol	Value		Unit
		TO252/TO-251	TO-220F	
Thermal Resistance, Junction-to-Case	$R_{\theta JC}$	2	4	$^{\circ}\text{C}/\text{W}$
Thermal Resistance, Junction-to-Ambient	$R_{\theta JA}$	62	68	$^{\circ}\text{C}/\text{W}$
Soldering temperature, wave soldering only allowed at leads. (1.6mm from case for 10s)	T_{sold}	260	260	$^{\circ}\text{C}$

Electrical Characteristics
 $T_c = 25^{\circ}\text{C}$ unless otherwise noted

Parameter	Symbol	Test Condition	Min.	Typ.	Max.	Unit
Static characteristics						
Drain-source breakdown voltage	BV_{DSS}	$V_{\text{GS}}=0\text{ V}, I_{\text{D}}=250\mu\text{A}$	650	-	-	V
Gate threshold voltage	$V_{\text{GS(th)}}$	$V_{\text{DS}}=V_{\text{GS}}, I_{\text{D}}=250\mu\text{A}$	2.5		4.0	V
Drain cut-off current	I_{DSS}	$V_{\text{DS}}=650\text{ V}, V_{\text{GS}}=0\text{ V},$ $T_j = 25^{\circ}\text{C}$ $T_j = 125^{\circ}\text{C}$	-	-	1	μA
Gate leakage current, Forward	I_{GSSF}	$V_{\text{GS}}=30\text{ V}, V_{\text{DS}}=0\text{ V}$	-	-	100	nA
Gate leakage current, Reverse	I_{GSSR}	$V_{\text{GS}}=-30\text{ V}, V_{\text{DS}}=0\text{ V}$	-	-	-100	nA
Drain-source on-state resistance	$R_{\text{DS(on)}}$	$V_{\text{GS}}=10\text{ V}, I_{\text{D}}=3.5\text{ A}$ $T_j = 25^{\circ}\text{C}$	-	0.53	0.60	Ω
Dynamic characteristics						
Input capacitance	C_{iss}	$V_{\text{DS}} = 100\text{ V}, V_{\text{GS}} = 0\text{ V},$ $f = 1\text{MHz}$	-	493	-	pF
Output capacitance	C_{oss}		-	32	-	
Reverse transfer capacitance	C_{rss}		-	1.6	-	
Turn-on delay time	$t_{\text{d(on)}}$	$V_{\text{DD}} = 400\text{V}, I_{\text{D}} = 3.5\text{A}$ $R_{\text{G}} = 25\Omega, V_{\text{GS}}=10\text{V}$	-	11.6	-	ns
Rise time	t_r		-	23	-	
Turn-off delay time	$t_{\text{d(off)}}$		-	53	-	
Fall time	t_f		-	35.8	-	
Gate charge characteristics						
Gate to source charge	Q_{gs}	$V_{\text{DD}}=520\text{ V}, I_{\text{D}}=3.5\text{A},$ $V_{\text{GS}}=0\text{ to }10\text{ V}$	-	2.8	-	nC
Gate to drain charge	Q_{gd}		-	4.7	-	
Gate charge total	Q_{g}		-	13.3	-	
Gate plateau voltage	V_{plateau}		-	5.5	-	V
Reverse diode characteristics						
Diode forward voltage	V_{SD}	$V_{\text{GS}}=0\text{ V}, I_{\text{F}}=3.5\text{A}$	-	0.85	-	V
Reverse recovery time	t_{rr}	$V_{\text{R}}=50\text{ V}, I_{\text{F}}=3.5\text{A},$ $dI_{\text{F}}/dt=100\text{ A}/\mu\text{s}$	-	201.4	-	ns
Reverse recovery charge	Q_{rr}		-	1.3	-	μC
Peak reverse recovery current	I_{rm}		-	11.5	-	A

Notes:

- Limited by maximum junction temperature, maximum duty cycle is 0.75.
- $I_{\text{AS}} = 2\text{A}, V_{\text{DD}} = 50\text{V},$ Starting $T_j = 25^{\circ}\text{C}.$

Electrical Characteristics Diagrams

Figure 1. Output Characteristics

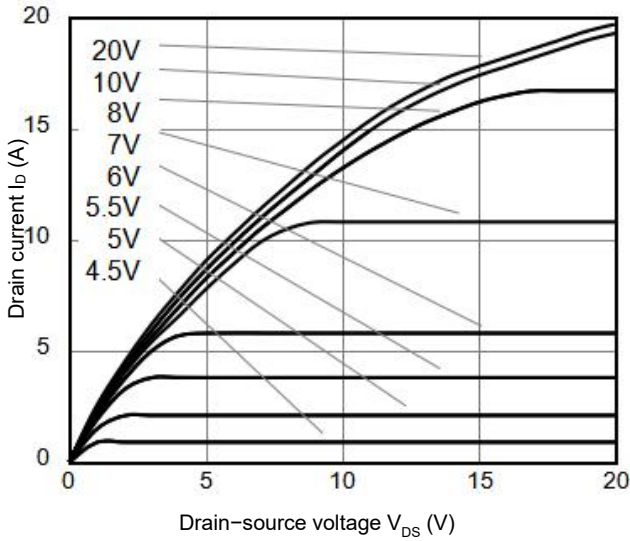

Figure 2. Transfer Characteristics

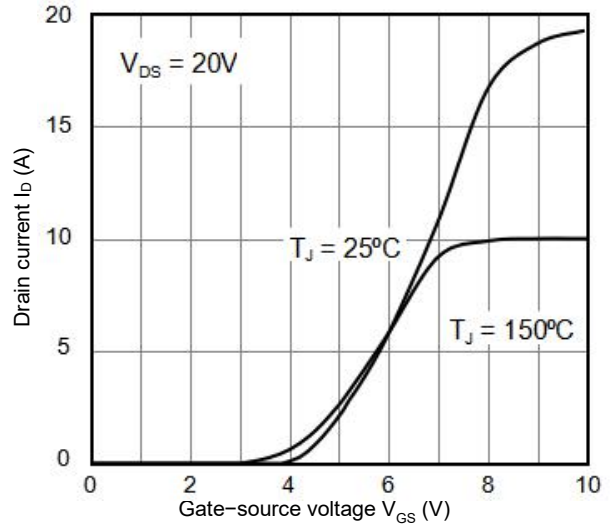

Figure 3. On-Resistance vs. Drain Current

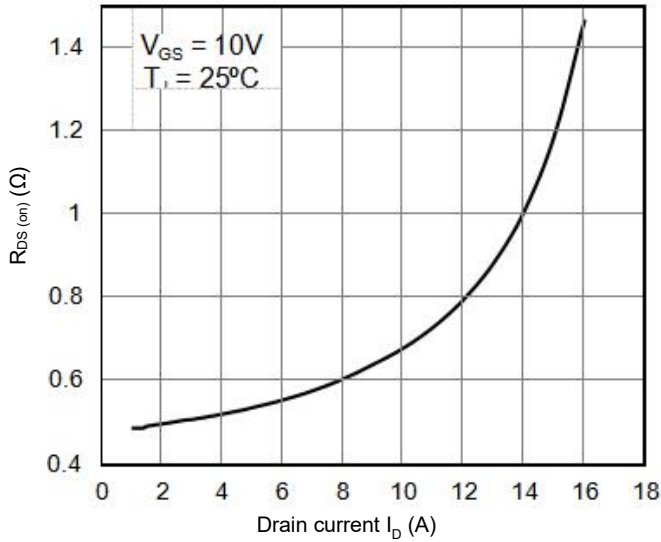

Figure 4. Capacitance Characteristics

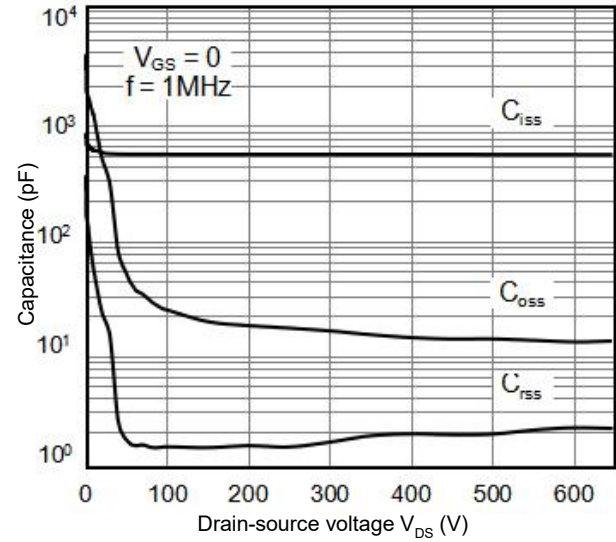

Figure 5. Gate Charge Characteristics

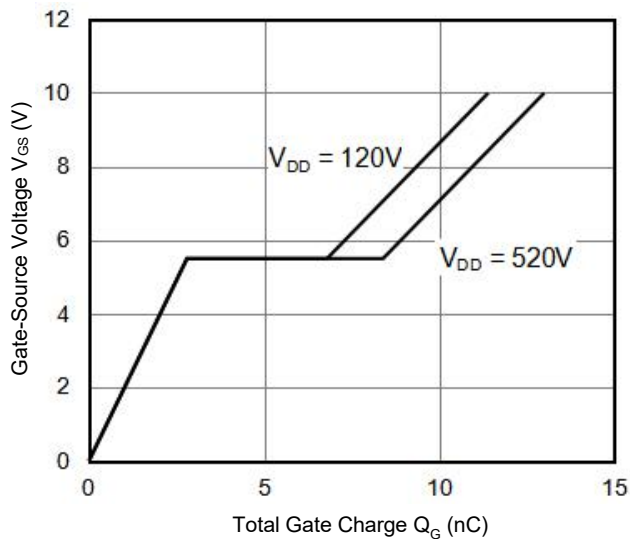

Figure 6. Body Diode Forward Voltage

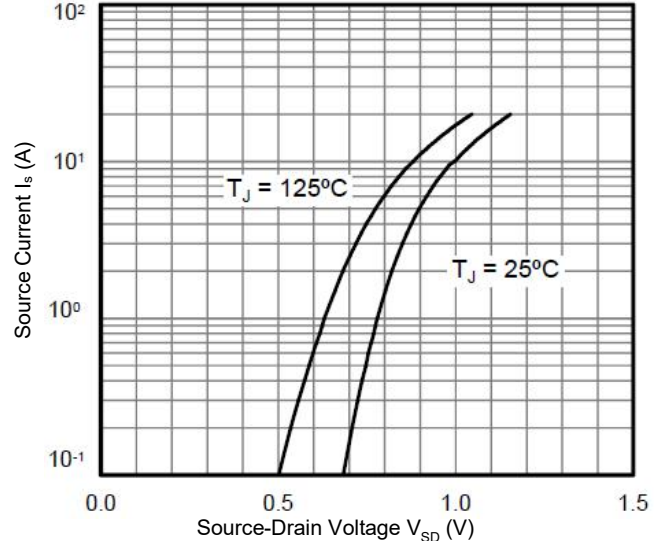

Figure 7. Breakdown Voltage vs. Temperature

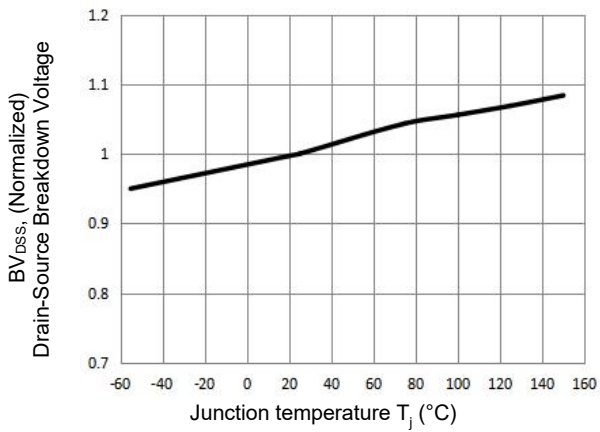

Figure 8. On-Resistance vs. Temperature

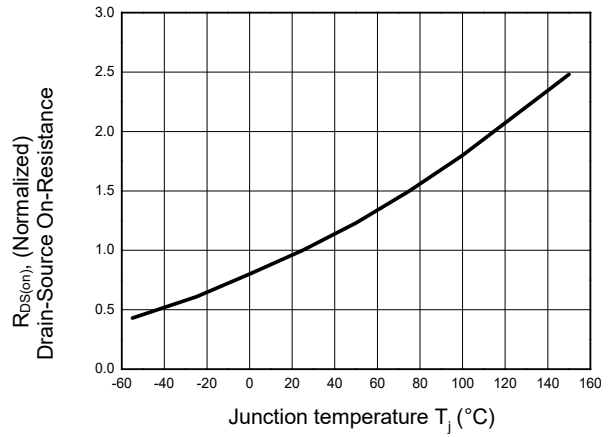

Figure 9. Maximum Safe Operating Area TO-252/TO-251

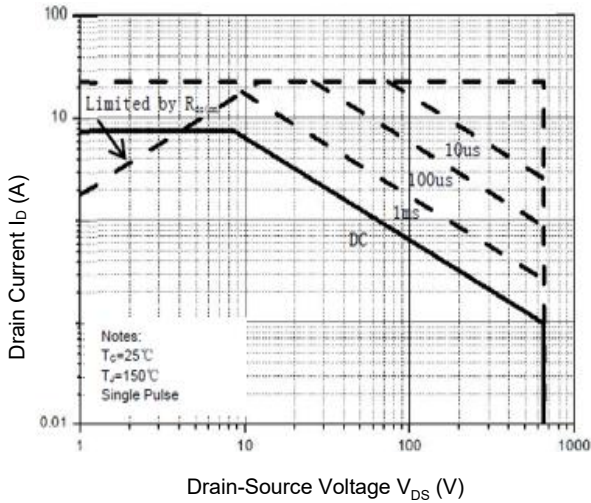
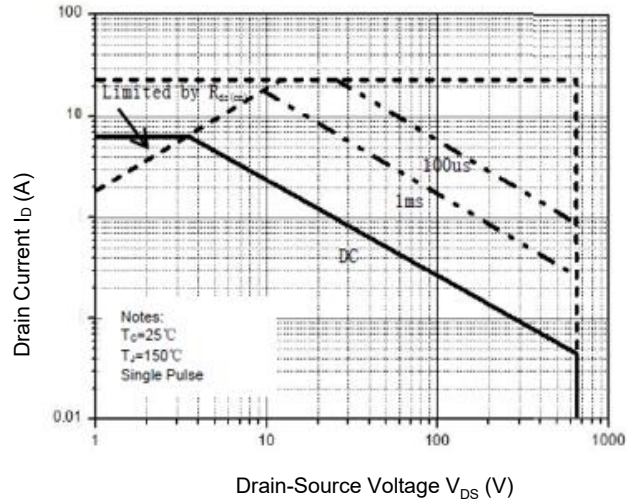
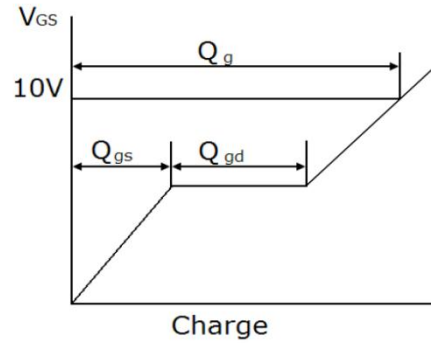
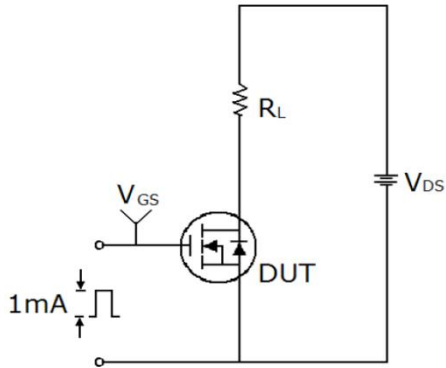

Figure 10. Maximum Safe Operating Area TO-220F



Test Circuits

Gate Charge Test Circuit & Waveform



Switching Test Circuit & Waveform

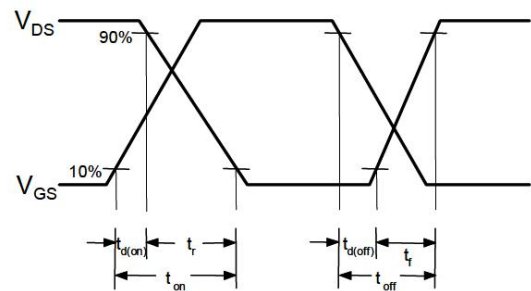
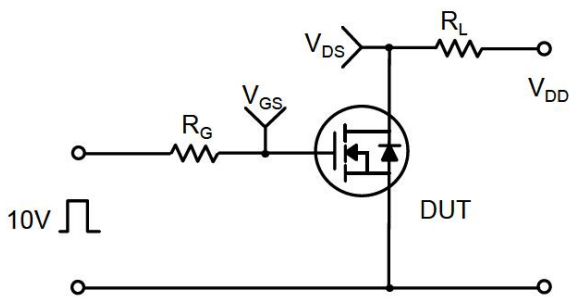

Unclamped Inductive Switching Test Circuit & Waveform

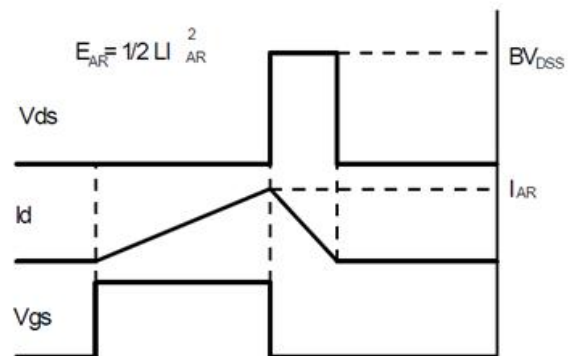
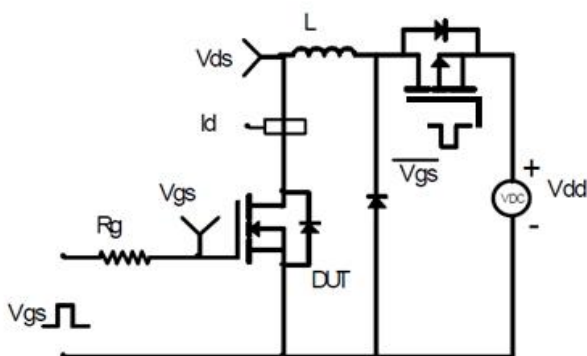

Mechanical Dimensions for TO-252

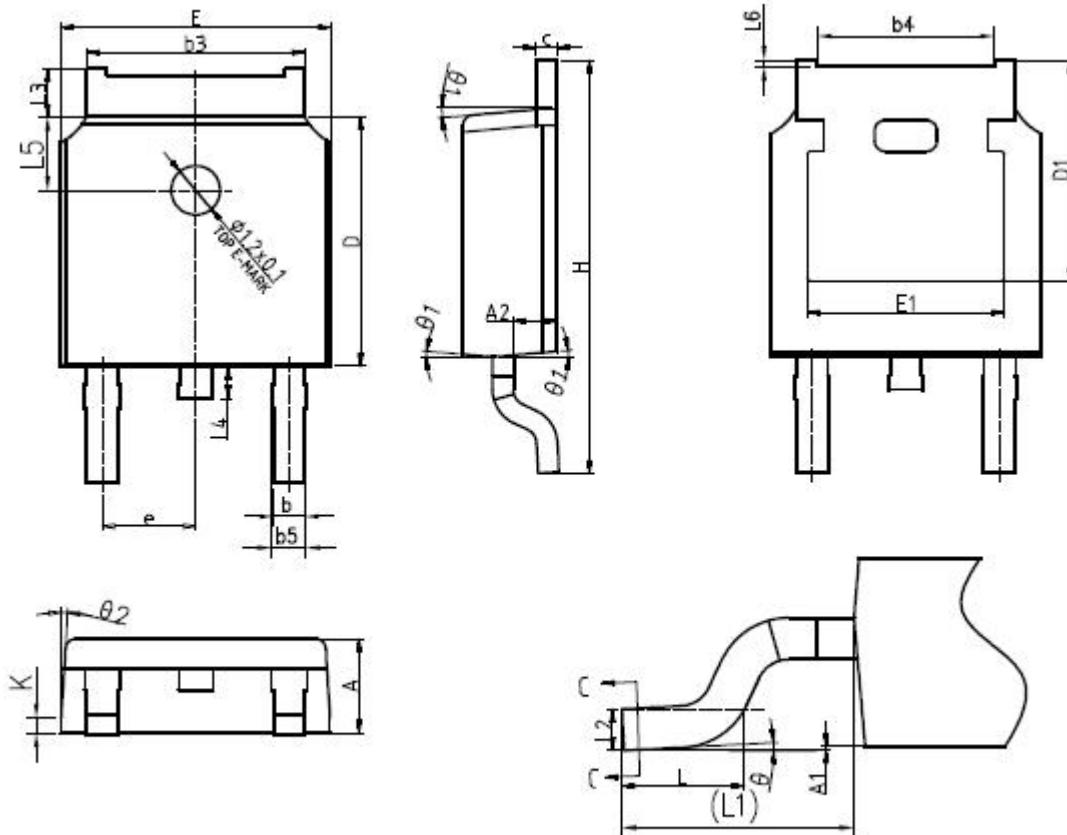

单位: mm

SYMBOL	mm		
	MIN	NOM	MAX
*A	2.20	2.30	2.38
*A1	0.00	-	0.10
A2	0.97	1.07	1.17
*b	0.72	0.78	0.85
b1	0.71	0.76	0.81
*b3	5.23	5.33	5.46
b4	4.27	4.32	4.37
b5	0.72	0.88	0.93
*c	0.47	0.53	0.58
c1	0.46	0.51	0.56
*D	6.00	6.10	6.20
D1	5.30REF		

*E	6.50	6.60	6.70
E1	4.70	4.83	4.92
*e	2.286BSC		
L	1.40	1.50	1.70
L1	2.90REF		
L2	0.51BSC		
*L3	0.90	-	1.25
*L4	0.60	0.80	1.00
L5	1.70	1.80	1.90
L6	0	0.047	0.123
theta	0°	-	8°
*theta 1	5°	7°	9°
theta 2	5°	7°	9°
K	0.40REF		

Mechanical Dimensions for TO-251

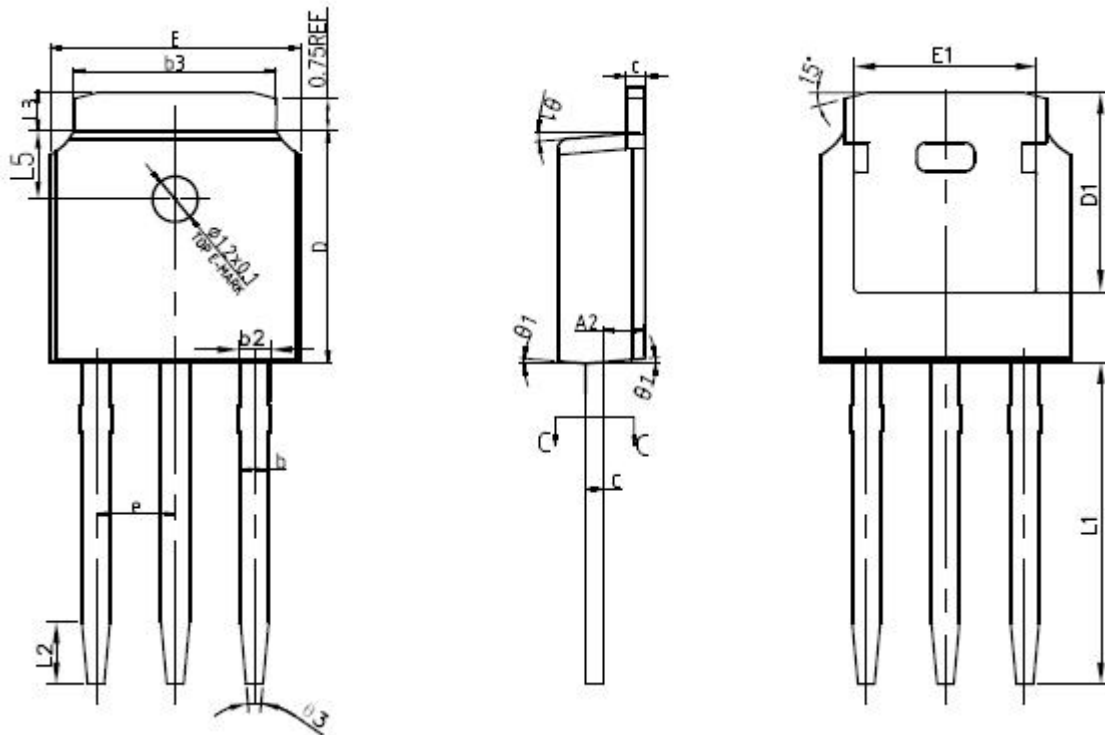

SYMBOL	MM		
	MIN	NOM	MAX
*A	2.20	2.30	2.38
*A2	0.97	1.07	1.17
*b	0.72	0.78	0.85
b1	0.71	0.76	0.81
*b2	0.72	0.88	0.95
*b3	5.23	5.33	5.46
*c	0.47	0.53	0.58
c1	0.46	0.51	0.56
*D	6.00	6.10	6.20
D1	5.30REF		
*E	6.50	6.60	6.70
E1	4.70	4.83	4.92
*e	2.286BSC		
*L1	9.20	9.40	9.60
L2	1.25	1.35	1.45
*L3	0.90	1.02	1.25
L5	1.70	1.80	1.90
* $\theta 1$	5°	7°	9°
$\theta 2$	5°	7°	9°
$\theta 3$	11°	13°	15°
K	0.40REF		

Mechanical Dimensions for TO-220F

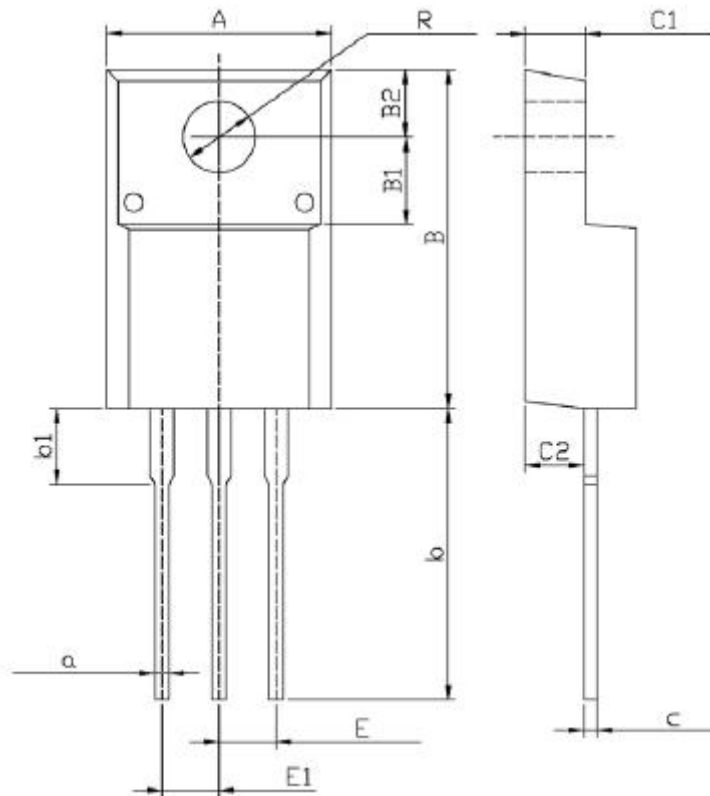

Symbol	Dimensions In Millimeters		Symbol	Dimensions In Millimeters	
	Min	Max		Min	Max
C	4.3	4.7	b1	2.9	3.9
A	9.7	10.3	a	0.55	0.75
B	14.7	15.3	E	2.29	2.79
B1	3.8	4.0	E1	2.29	2.79
B2	2.9	3.1	C1	2.5	2.9
R	3.0	3.4	C2	2.5	2.7
b	12.5	13.5	c	0.5	0.7