

### FEATURES

- Maximum output current  
 $I_{OM}$ : 0.1A
- Output voltage  
 $V_O$ : 8V
- Continuous total dissipation  
 $P_D$ : 0.5 W

### SOT-89-3L

1. OUT
2. GND
3. IN

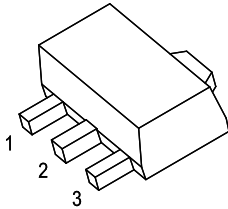

### SOT-89 PACKAGE OUTLINE

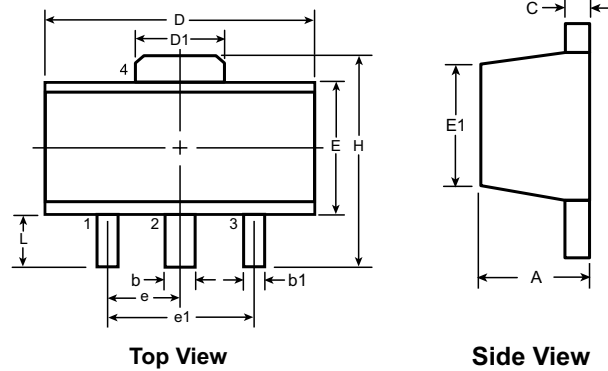

Symbol	A	b	b1	C	D	D1	E	E1	e	e1	H	L
Dimensions (mm)	MIN	1.40	0.44	0.36	0.3	4.40	1.50	2.29	2.00'	1.50	3.94	0.89
	NOM	-	-	-	-	-	-	-	-	3.00	-	-
	MAX	1.60	0.56	0.48	0.5	4.60	1.75	2.60	2.29	BSC	4.25	1.20

Dimensions in mm

### ABSOLUTE MAXIMUM RATINGS (Operating temperature range applies unless otherwise specified)

Parameter	Symbol	Value	Units
Input Voltage	$V_I$	30	V
Operating Junction Temperature Range	$T_{OPR}$	0~+150	°C
Storage Temperature Range	$T_{STG}$	-55~+150	°C

# 78L08

ELECTRICAL CHARACTERISTICS AT SPECIFIED VIRTUAL JUNCTION TEMPERATURE ( $V_i=14V$ ,  $I_o=40mA$ ,  $C_i=0.33\mu F$ ,  $C_o=0.1\mu F$ , unless otherwise specified )

Parameter	Symbol	Test conditions	Min	Typ	Max	Unit	
Output voltage	$V_o$	$25^\circ C$	7.7	8.0	8.3	V	
		$10.5V \leq V_i \leq 23V$ , $I_o=1mA \sim 40mA$	0-125°C	7.6	8.0	8.4	V
		$I_o=1mA \sim 70mA$		7.6	8.0	8.4	V
Load Regulation	$\Delta V_o$	$I_o=1mA \sim 100mA$	$25^\circ C$		18	80	mV
		$I_o=1mA \sim 40mA$	$25^\circ C$		10	40	mV
Line regulation	$\Delta V_o$	$10.5V \leq V_i \leq 23V$	$25^\circ C$		42	175	mV
		$11V \leq V_i \leq 23V$	$25^\circ C$		36	125	mV
Quiescent Current	$I_q$		$25^\circ C$		4	6	mA
Quiescent Current Change	$\Delta I_q$	$11V \leq V_i \leq 23V$	0-125°C			1.5	mA
	$\Delta I_q$	$1mA \leq I_o \leq 40mA$	0-125°C			0.1	mA
Output Noise Voltage	$V_N$	$10Hz \leq f \leq 100KHz$	$25^\circ C$		54		$\mu V$
Ripple Rejection	RR	$13V \leq V_i \leq 23V, f=120Hz$	0-125°C	37	46		dB
Dropout Voltage	$V_d$		$25^\circ C$		1.7		V

## TYPICAL APPLICATION

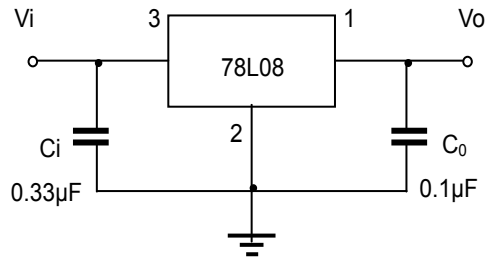

Note: Bypass capacitors are recommended for optimum stability and transient response and should be located as close as possible to the regulators.

# RATING AND CHARACTERISTIC CURVES (78L08)

**Output Characteristics**

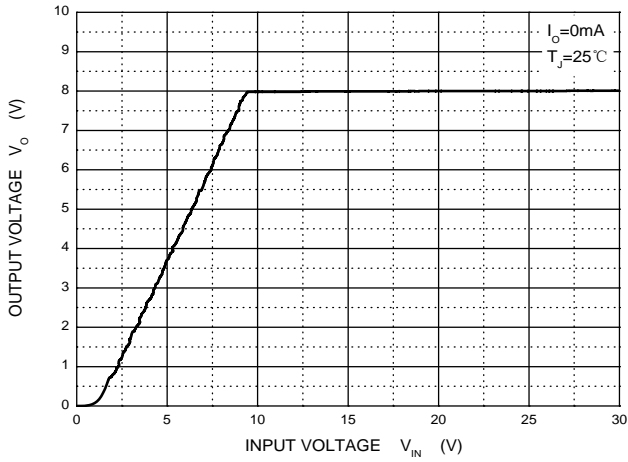

**Dropout Characteristics**

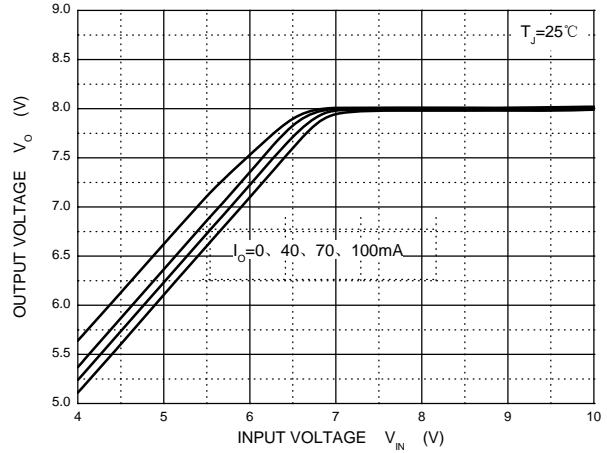

**Quiescent Current vs Input Voltage**

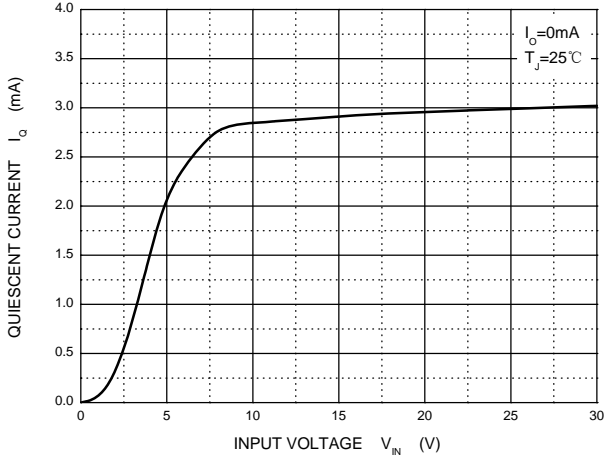

**Current Cut-off Grid Voltage**

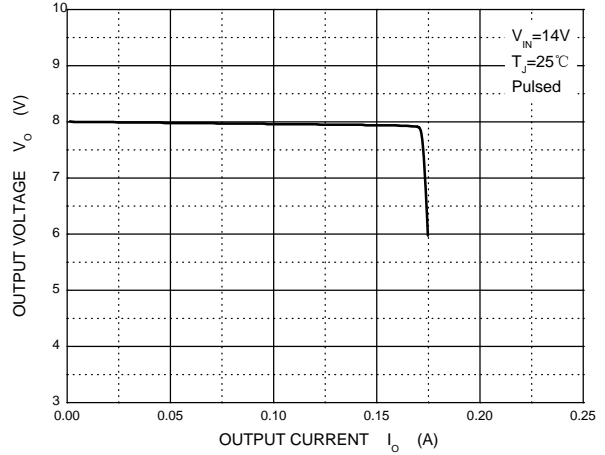

**Output Voltage vs Junction Temperature**

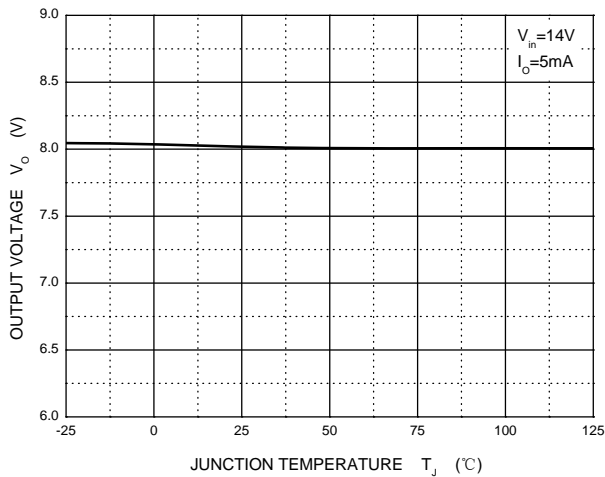

**Power Derating Curve**

