





N-channel 700V, 11A, 0.38Ω Super-Junction Power MOSFET

<p>Description Super-junction power MOSFET is a revolutionary technology for high voltage power MOSFET , designed according to the SJ principle. The resulting device has extremely low on resistance,making it especially suitable for applications which require superior power density and outstanding efficiency.</p> <p>Features</p> <ul style="list-style-type: none"> ◆ Very low FOM $R_{DS(on)} \times Q_g$ ◆ 100% UIS tested ◆ RoHS compliant <p>Applications</p> <ul style="list-style-type: none"> ◆ Power factor correction (PFC). ◆ Switched mode power supplies (SMPS). ◆ Uninterrupted power supply (UPS). 	<p>Product Summary</p> <table> <tr> <td>$V_{DS} @ T_{j,25^{\circ}C}$</td> <td>700V</td> </tr> <tr> <td>$R_{DS(on),max}$</td> <td>0.38Ω</td> </tr> <tr> <td>I_D</td> <td>11A</td> </tr> <tr> <td>$Q_{g,typ}$</td> <td>19.2 nC</td> </tr> </table> <div style="display: flex; justify-content: space-around; align-items: center;"> <div style="text-align: center;">  TO-252 </div> <div style="text-align: center;">  TO-251 </div> <div style="text-align: center;">  TO-220F </div> </div> <div style="text-align: center; margin-top: 20px;">  N-Channel MOSFET </div> <div style="text-align: right; margin-top: 20px;">  </div>	$V_{DS} @ T_{j,25^{\circ}C}$	700V	$R_{DS(on),max}$	0.38Ω	I_D	11A	$Q_{g,typ}$	19.2 nC
$V_{DS} @ T_{j,25^{\circ}C}$	700V								
$R_{DS(on),max}$	0.38Ω								
I_D	11A								
$Q_{g,typ}$	19.2 nC								

Marking information

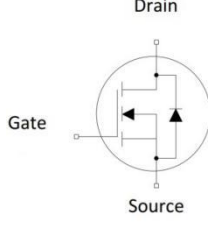
Product	Package	Marking	Packing method
RMA70R380SN	TO-252	RMA70R380SN	Reel
RMG70R380SN	TO-251	RMG70R380SN	Tube
RMC70R380SN	TO-220F	RMC70R380SN	Tube

Absolute Maximum Ratings

Parameter	Symbol	Value	Unit
Drain-Source Voltage	V_{DSS}	700	V
Continuous drain current ($T_C = 25^{\circ}C$) ($T_C = 100^{\circ}C$)	I_D	11 7	A A
Pulsed drain current ¹⁾	I_{DM}	33	A
Gate-Source voltage	V_{GSS}	±30	V
Avalanche energy, single pulse ²⁾	E_{AS}	210	mJ
Avalanche current, repetitive ³⁾	I_{AR}	1.6	A
Power Dissipation TO-252 /TO-251 ($T_C = 25^{\circ}C$) - Derate above 25°C	P_D	118 0.94	W W/°C
Power Dissipation TO-220F ($T_C = 25^{\circ}C$) - Derate above 25°C	P_D	33 0.26	W W/°C
Operating and Storage Temperature Range	T_J, T_{STG}	-55 to +150	°C
Continuous diode forward current	I_S	11	A
Diode pulse current	$I_{S,pulse}$	33	A

Thermal Characteristics

Parameter	Symbol	Value		Unit
		TO252/TO-251	TO-220F	
Thermal Resistance, Junction-to-Case	$R_{\theta JC}$	1.32	3.6	$^{\circ}\text{C}/\text{W}$
Thermal Resistance, Junction-to-Ambient	$R_{\theta JA}$	87	62	$^{\circ}\text{C}/\text{W}$
Soldering temperature, wave soldering only allowed at leads. (1.6mm from case for 10s)	T_{sold}	260	260	$^{\circ}\text{C}$

Electrical Characteristics
 $T_c = 25^{\circ}\text{C}$ unless otherwise noted

Parameter	Symbol	Test Condition	Min.	Typ.	Max.	Unit
Static characteristics						
Drain-source breakdown voltage	BV_{DSS}	$V_{\text{GS}}=0\text{ V}, I_{\text{D}}=250\mu\text{A}$	700	-	-	V
Gate threshold voltage	$V_{\text{GS(th)}}$	$V_{\text{DS}}=V_{\text{GS}}, I_{\text{D}}=250\mu\text{A}$	2.5	-	4.0	V
Drain cut-off current	I_{DSS}	$V_{\text{DS}}=700\text{ V}, V_{\text{GS}}=0\text{ V},$ $T_j = 25^{\circ}\text{C}$ $T_j = 125^{\circ}\text{C}$	-	-	1	μA
Gate leakage current, Forward	I_{GSSF}	$V_{\text{GS}}=30\text{ V}, V_{\text{DS}}=0\text{ V}$	-	-	100	nA
Gate leakage current, Reverse	I_{GSSR}	$V_{\text{GS}}=-30\text{ V}, V_{\text{DS}}=0\text{ V}$	-	-	-100	nA
Drain-source on-state resistance	$R_{\text{DS(on)}}$	$V_{\text{GS}}=10\text{ V}, I_{\text{D}}=5.5\text{ A}$ $T_j = 25^{\circ}\text{C}$	-	0.34	0.38	Ω
Dynamic characteristics						
Input capacitance	C_{iss}	$V_{\text{DS}} = 100\text{ V}, V_{\text{GS}} = 0\text{ V},$ $f = 1\text{ MHz}$	-	852	-	pF
Output capacitance	C_{oss}		-	37	-	
Reverse transfer capacitance	C_{rss}		-	2.0	-	
Turn-on delay time	$t_{\text{d(on)}}$	$V_{\text{DD}} = 400\text{ V}, I_{\text{D}} = 5.5\text{ A}$ $R_{\text{G}} = 25\Omega, V_{\text{GS}}=10\text{ V}$	-	16.3	-	ns
Rise time	t_{r}		-	35	-	
Turn-off delay time	$t_{\text{d(off)}}$		-	78	-	
Fall time	t_{f}		-	39.5	-	
Gate charge characteristics						
Gate to source charge	Q_{gs}	$V_{\text{DD}}=560\text{ V}, I_{\text{D}}=5.5\text{ A},$ $V_{\text{GS}}=0\text{ to }10\text{ V}$	-	3.1	-	nC
Gate to drain charge	Q_{gd}		-	8.2	-	
Gate charge total	Q_{g}		-	19.2	-	
Gate plateau voltage	V_{plateau}		-	5.5	-	V
Reverse diode characteristics						
Diode forward voltage	V_{SD}	$V_{\text{GS}}=0\text{ V}, I_{\text{F}}=5.5\text{ A}$	-	0.85	-	V
Reverse recovery time	t_{rr}	$V_{\text{R}}=400\text{ V}, I_{\text{F}}=5.5\text{ A},$ $dI_{\text{F}}/dt=100\text{ A}/\mu\text{s}$	-	310	-	ns
Reverse recovery charge	Q_{rr}		-	2.8	-	μC
Peak reverse recovery current	I_{rm}		-	16.8	-	A

Notes:

- Limited by maximum junction temperature, maximum duty cycle is 0.75.
- $I_{\text{AS}} = 3\text{ A}, V_{\text{DD}} = 50\text{ V},$ Starting $T_j = 25^{\circ}\text{C}.$

Electrical Characteristics Diagrams

Figure 1. Output Characteristics

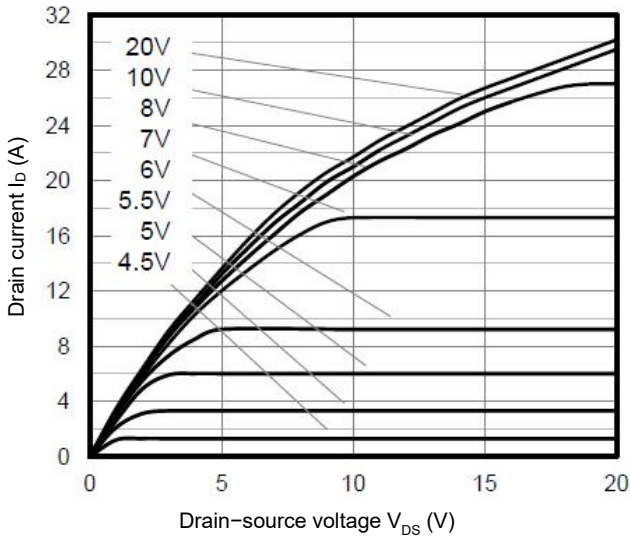

Figure 2. Transfer Characteristics

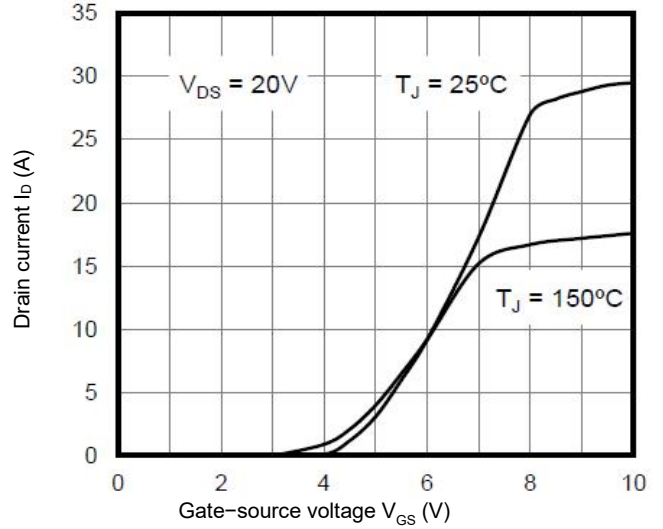

Figure 3. On-Resistance vs. Drain Current

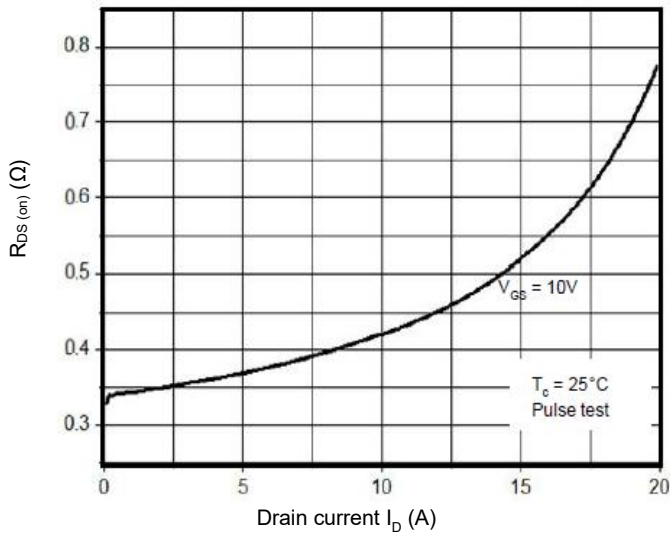

Figure 4. Capacitance Characteristics

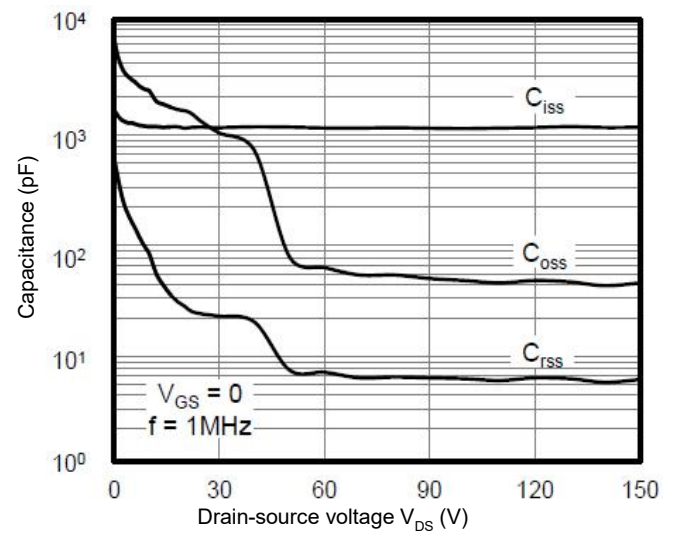

Figure 5. Gate Charge Characteristics

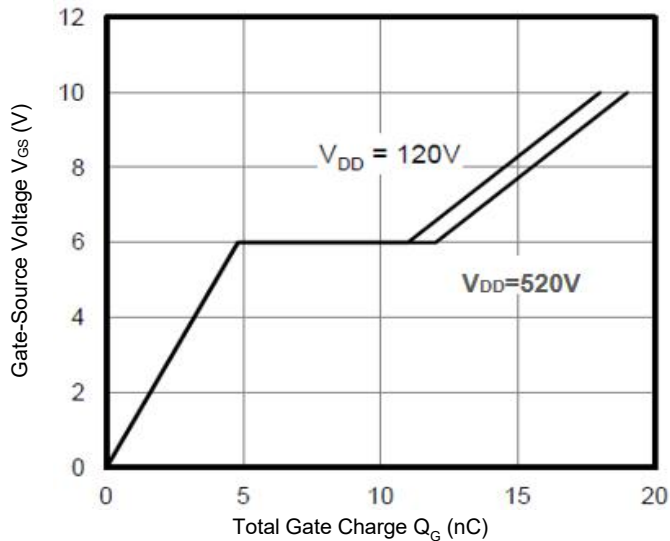

Figure 6. Body Diode Forward Voltage

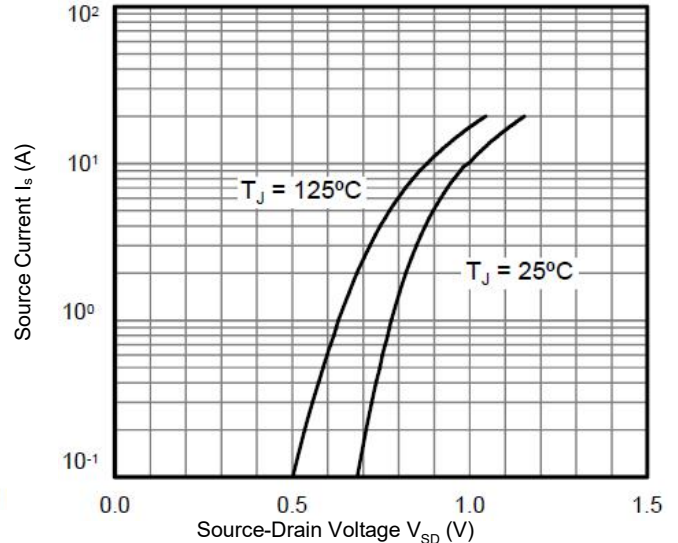

Figure 7. Breakdown Voltage vs. Temperature

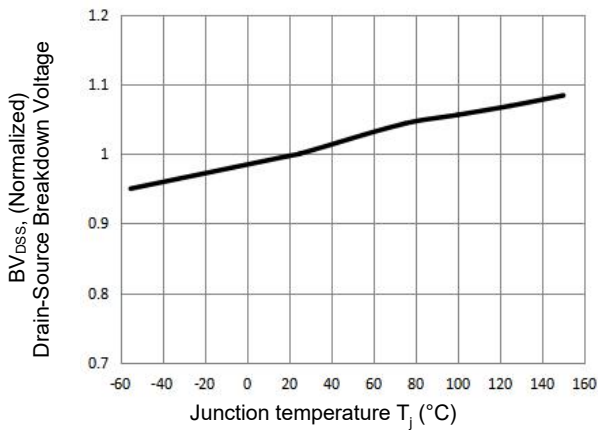

Figure 8. On-Resistance vs. Temperature

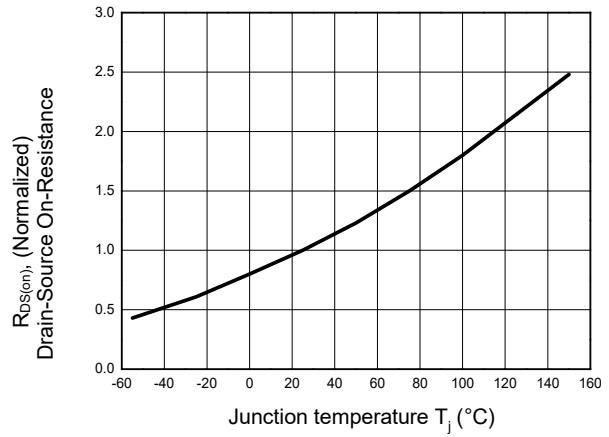

Figure 9. Maximum Safe Operating Area
TO-252/TO-251

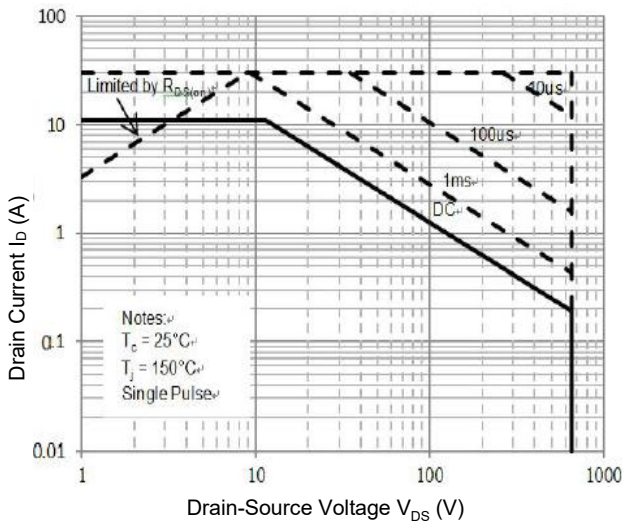
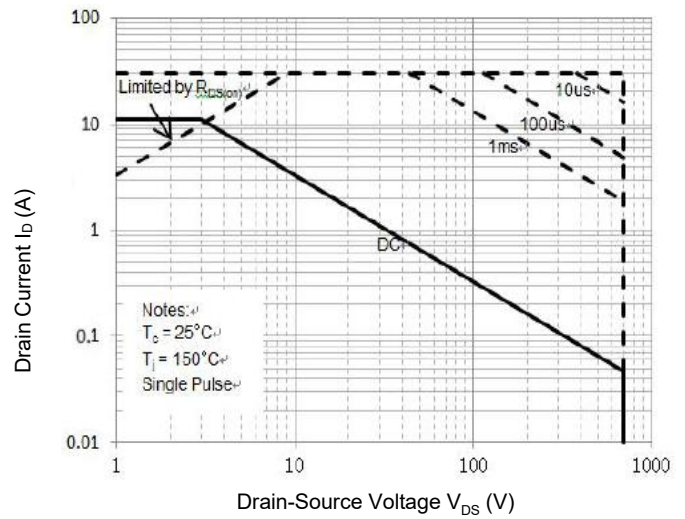
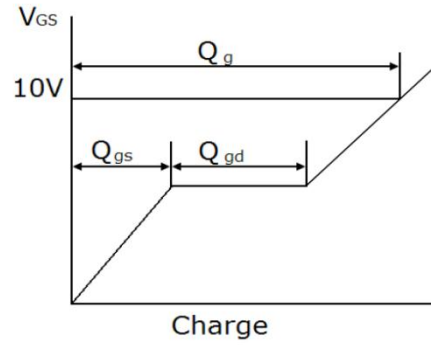
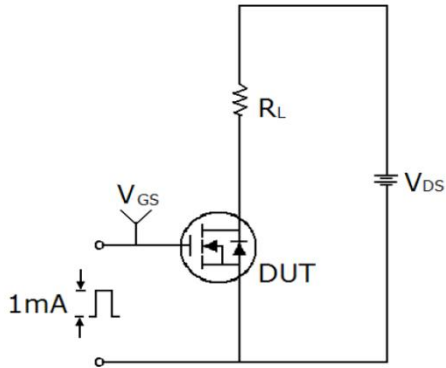

Figure 10. Maximum Safe Operating Area
TO-220F



Test Circuits

Gate Charge Test Circuit & Waveform



Switching Test Circuit & Waveform

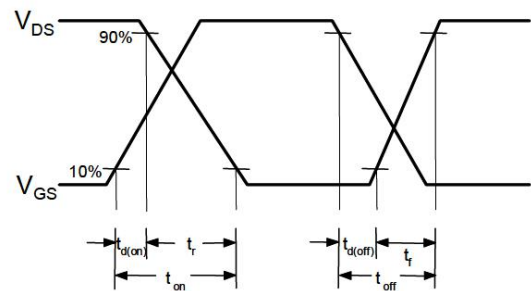
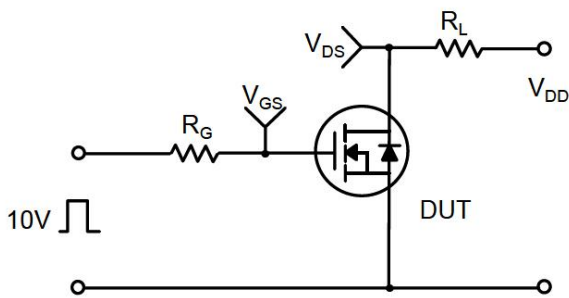

Unclamped Inductive Switching Test Circuit & Waveform

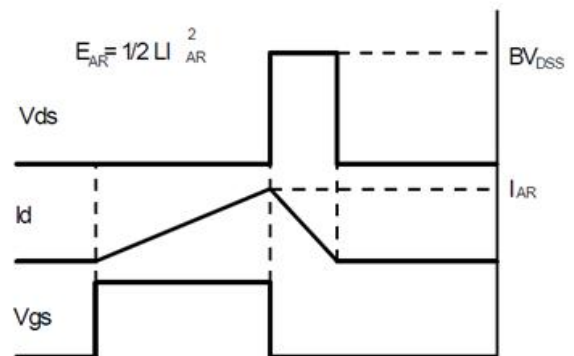
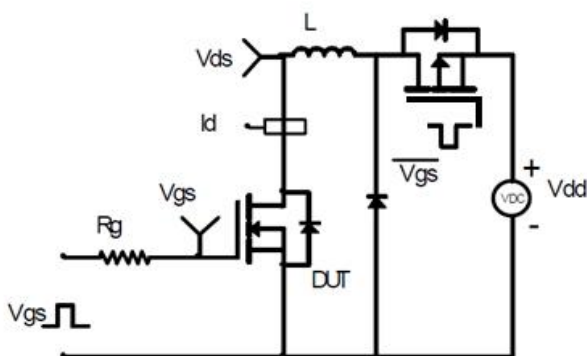

Mechanical Dimensions for TO-252

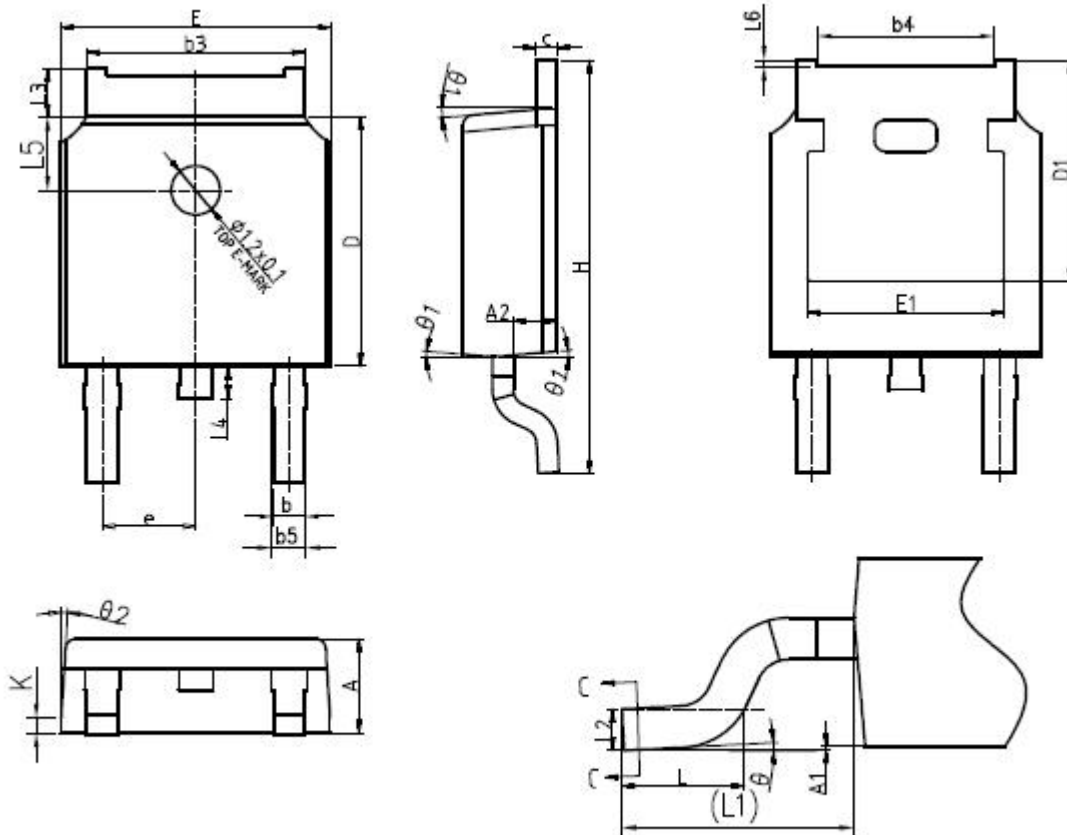

单位: mm

SYMBOL	mm		
	MIN	NOM	MAX
*A	2.20	2.30	2.38
*A1	0.00	-	0.10
A2	0.97	1.07	1.17
*b	0.72	0.78	0.85
b1	0.71	0.76	0.81
*b3	5.23	5.33	5.46
b4	4.27	4.32	4.37
b5	0.72	0.88	0.93
*c	0.47	0.53	0.58
c1	0.46	0.51	0.56
*D	6.00	6.10	6.20
D1	5.30REF		

*E	6.50	6.60	6.70
E1	4.70	4.83	4.92
*e	2.286BSC		
L	1.40	1.50	1.70
L1	2.90REF		
L2	0.51BSC		
*L3	0.90	-	1.25
*L4	0.60	0.80	1.00
L5	1.70	1.80	1.90
L6	0	0.047	0.123
θ	0°	-	8°
* $\theta 1$	5°	7°	9°
$\theta 2$	5°	7°	9°
K	0.40REF		

Mechanical Dimensions for TO-251

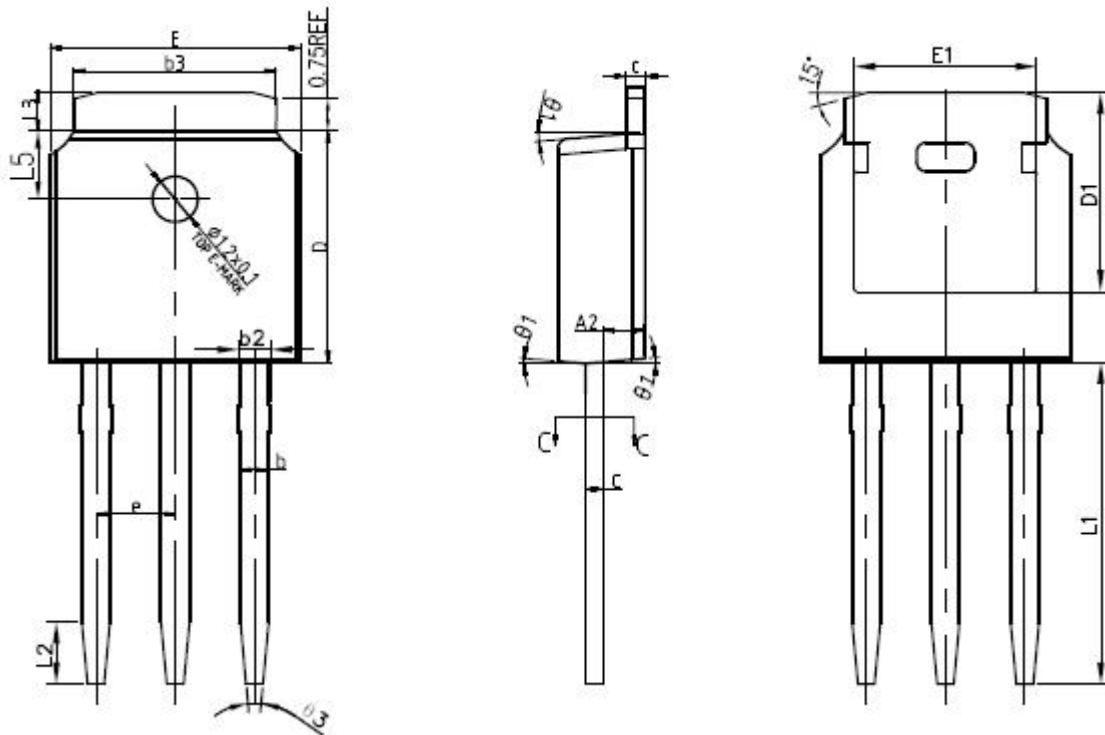

SYMBOL	MM		
	MIN	NOM	MAX
*A	2.20	2.30	2.38
*A2	0.97	1.07	1.17
*b	0.72	0.78	0.85
b1	0.71	0.76	0.81
*b2	0.72	0.88	0.95
*b3	5.23	5.33	5.46
*c	0.47	0.53	0.58
c1	0.46	0.51	0.56
*D	6.00	6.10	6.20
D1	5.30REF		
*E	6.50	6.60	6.70
E1	4.70	4.83	4.92
*e	2.286BSC		
*L1	9.20	9.40	9.60
L2	1.25	1.35	1.45
*L3	0.90	1.02	1.25
L5	1.70	1.80	1.90
* $\theta 1$	5°	7°	9°
$\theta 2$	5°	7°	9°
$\theta 3$	11°	13°	15°
K	0.40REF		

Mechanical Dimensions for TO-220F

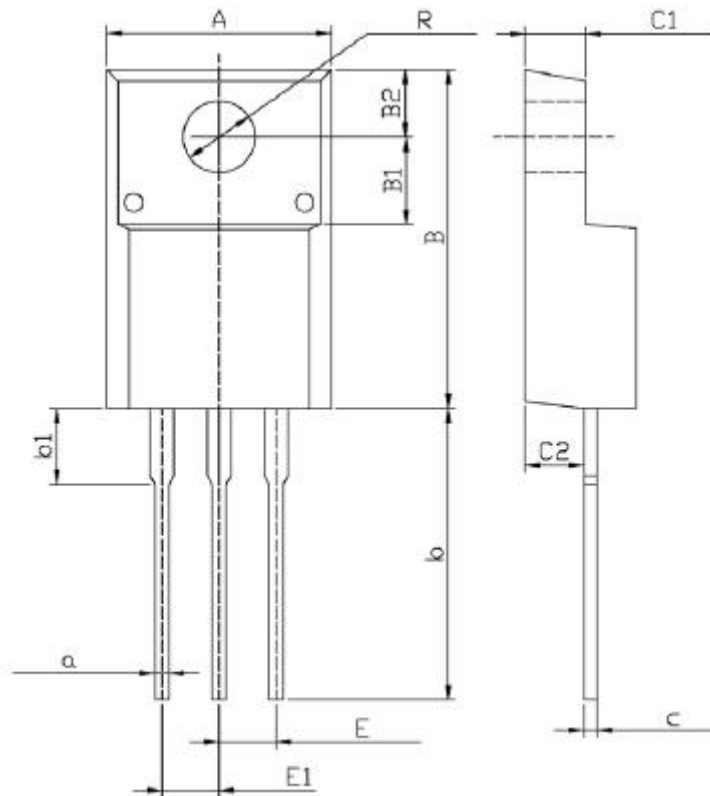

Symbol	Dimensions In Millimeters		Symbol	Dimensions In Millimeters	
	Min	Max		Min	Max
C	4.3	4.7	b1	2.9	3.9
A	9.7	10.3	a	0.55	0.75
B	14.7	15.3	E	2.29	2.79
B1	3.8	4.0	E1	2.29	2.79
B2	2.9	3.1	C1	2.5	2.9
R	3.0	3.4	C2	2.5	2.7
b	12.5	13.5	c	0.5	0.7