

FX8 Series

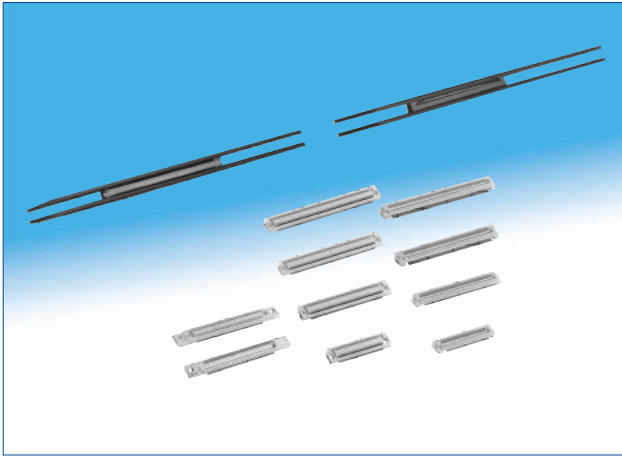

FX8C Series

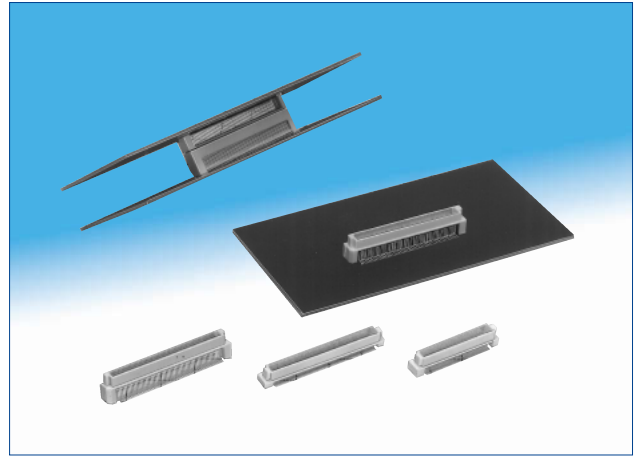

Note: that FX8 series and FX8C series are not mated with each other.

### ■ Features

#### 1. Stacking Height: 3mm to 16mm

Stacking height of mated connectors ranges from 3mm to 16mm. (Fig.1.2)

#### 2. SMT Coplanarity

The coplanar tolerance at the solder area is less than 0.1mm.

#### 3. Mating Guide

Built-in guide ribs and a chamfer allow for  $\pm 0.6$  mm of mis-alignmet and ensures easy mating.

#### 4. Mis-insertion Prevention

Bosses located on the bottom side of the connector differ in position and diameter to prevent mis-orientating the parts on the board.

#### 5. Dual Connected Products

In order to enhance mounting reliability and accuracy when mounting two of the same connectors at the same time, Hirose offers the option of having two connectors attached to one another by means of a spacer. Pitch between the two connectors is 11mm.

#### ● Stacking Height 3,4mm-FX8 Series

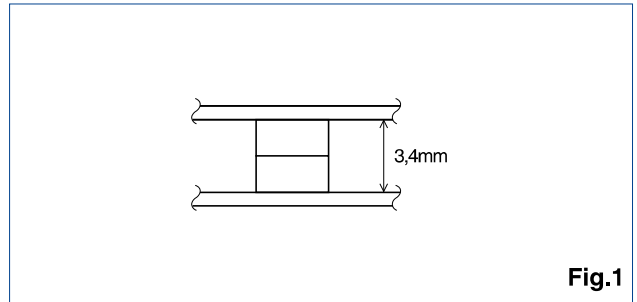

Fig.1

#### ● Stacking Height 5 to 16mm-FX8C Series

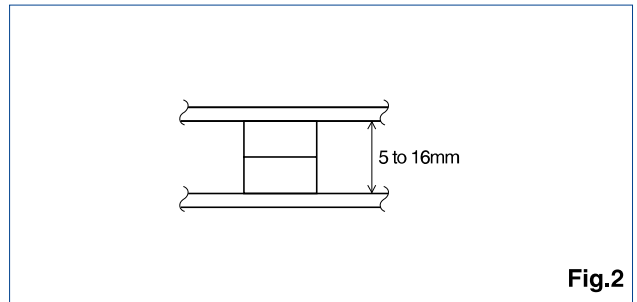

Fig.2

# FX8 Series

## Product Specifications

Rating	Current rating 0.4A Voltage rating 100V AC	Operating Temperature Range -55°C to +85°C (Note 1) Operating Humidity Range -40% to 80%	Storage Temperature Range -10°C to +60°C (Note 2) Storage Humidity Range 40% to 70% (Note 2)
--------	---	---	---

Items	Specifications	Conditions
1. Insulation Resistance	1000MΩ min	250V DC
2. Withstanding voltage	No flashover or insulation breakdown.	300V AC/1 min
3. Contact Resistance	45mΩ max.	100mA
4. Vibration	No electrical discontinuity of 1μs or more	Frequency : 10 to 55Hz, single amplitude of 0.75mm, 2 hours in each of the 3 axis directions.
5. Humidity (Steady state)	Contact resistance : 55mΩ max. : Insulation resistance : 100MΩ min.	96 hours at 40°C and humidity of 90% to 95%
6. Temperature Cycle	Contact resistance : 55mΩ max. : Insulation resistance : 100MΩ min.	(-55°C : 30 minutes, 15 to 35°C : 2 to 3 minutes 85°C : 30 minutes, 15 to 35°C : 2 to 3 minutes) 5 cycles
7. Mating Cycles	Contact resistance : 55mΩ max.	50 cycles
8. Resistance to Soldering heat	No deformation of components affecting performance.	Reflow : At the recommended temperature profile Manual soldering : 360°C for 5 seconds

Note 1 : Includes temperature rise caused by current flow.

Note 2 : The term "storage" refers to products stored for long period of time prior to mounting and use. Operating Temperature Range and Humidity range includes the non conducting condition in storage, shipment or during transportation.

## Material / Finish

Part	Material	Finish	Remarks	
Insulator	PPS	Light brown	UL94V-0	
Header Contact	Phosphor bronze	Contact area	Gold plated	
		Lead area	Tin (Note 2)	
Receptacle Contact		Contact area	Gold plated	_____
		Lead area		

Note 1 : Slight color difference to the resin may occur. This will not affect fit, form or function of the connector.

Note 2 : FX8-\*P-SV is gold plated.

## Product Number Structure

Refer to the chart below when determining the product specifications from the product number. Please select from the product numbers listed in this catalog when placing orders.

### Single Product

**FX8 - 120 P - SV 1 (92)**

①      ②      ③      ④      ⑤      ⑥

① Series Name : FX8
② No. of contacts : 60, 80, 90, 120, 140
③ Connector type      P : Header S : Receptacle
④ Contact type      SV : Board vertical type
⑤ Product height variation : none= standard (minimum low profile) 1 : +1mm
⑥ Package Form None, (71) : Tray package product (21), (91) : Tube packaging product (22), (92) : Emboss tape package product

### Mating Sectional View

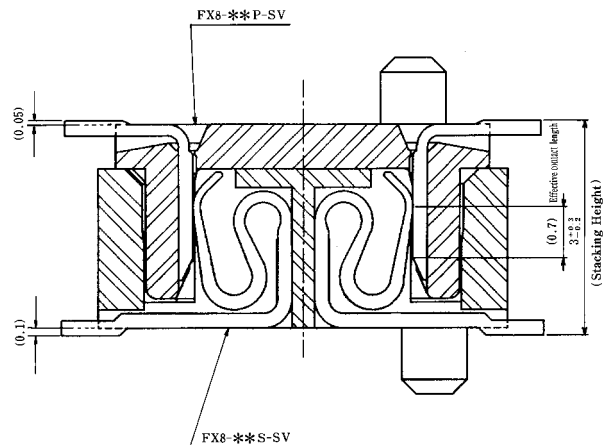

(The above illustration represents the stacking height 3mm type.)

## Stacking Height Variation

### Single Product

	FX8-***P-SV	FX8-***P-SV1
FX8-***S-SV	3mm	4mm

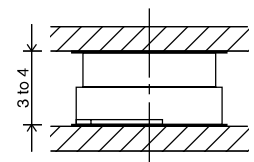

Header

[FX8-\*\*-P-SV]

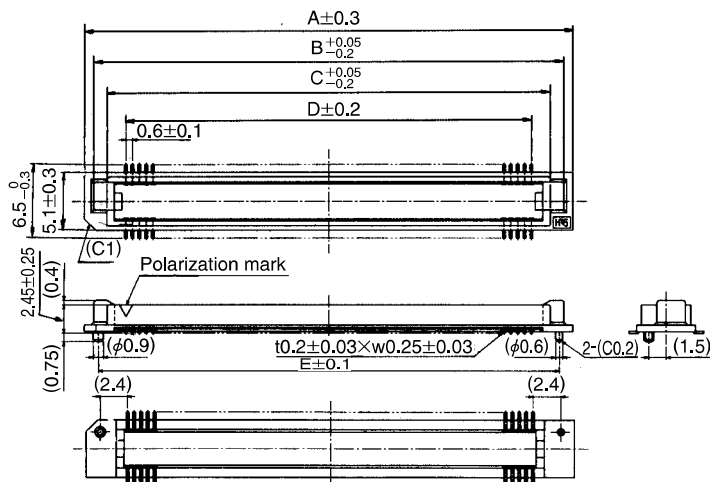
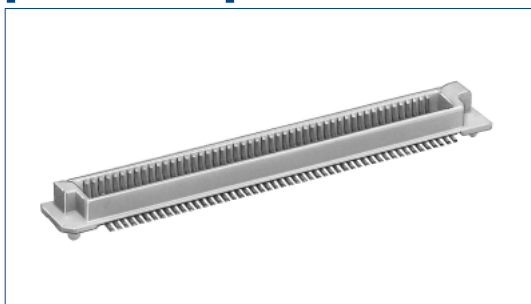

Unit : mm

Part No.**	HRS No.	No. of contacts	A	B	C	D	E	RoHS
FX8-60P-SV(**)	578-0001-6 **	60	24.60	23.00	20.70	17.40	22.20	Yes
FX8-80P-SV(**)	578-0003-1 **	80	30.60	29.00	26.70	23.40	28.20	
FX8-90P-SV(**)	578-0004-4 **	90	33.60	32.00	29.70	26.40	31.20	
FX8-100P-SV(**)	578-0005-7 **	100	36.60	35.00	32.70	29.40	34.20	
FX8-120P-SV(**)	578-0006-0 **	120	42.60	41.00	38.70	35.40	40.20	
FX8-140P-SV(**)	578-0007-2 **	140	48.60	47.00	44.70	41.40	46.20	

\*\* 71 : Tray packaging, 91 : Tube packaging, 92 : Embossed tape packaging

Note 1 : Please place orders in full magazine/tube quantities.

Note 2 : Reels are sold containing 1,000 pcs/reel. Please refer to the delivery form on page 6 for details.

Note 3 : Please note that tray packaged parts are not suitable for use with automatic mounting processes.

[FX8-\*\*\*P-SV1]

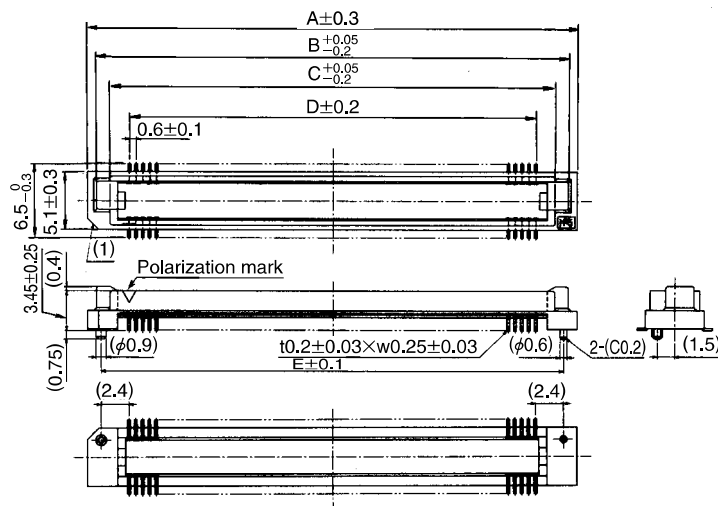
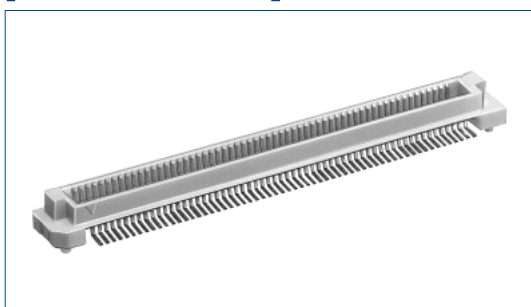

Unit : mm

Part No.**	HRS No.	No. of contacts	A	B	C	D	E	RoHS
FX8-60P-SV1(**)	578-0041-0 **	60	24.60	23.00	20.70	17.40	22.20	Yes
FX8-80P-SV1(**)	578-0043-6 **	80	30.60	29.00	26.70	23.40	28.20	
FX8-90P-SV1(**)	578-0044-9 **	90	33.60	32.00	29.70	26.40	31.20	
FX8-100P-SV1(**)	578-0045-1 **	100	36.60	35.00	32.70	29.40	34.20	
FX8-120P-SV1(**)	578-0046-4 **	120	42.60	41.00	38.70	35.40	40.20	
FX8-140P-SV1(**)	578-0047-7 **	140	48.60	47.00	44.70	41.40	46.20	

\*\* 71 : Tray packaging, 91 : Tube packaging, 92 : Embossed tape packaging

Note 1 : Please place orders in full magazine/tube quantities.

Note 2 : The embossed tape packaged parts are available for all pin counts, except the 140 pin count. Reels are sold containing 1,000 pcs/reel. Please refer to the delivery form on page 15 for details.

Note 3 : Please note that tray packaged parts are not suitable for use with automatic mounting processes.

## ■ Receptacle

[FX8-\*\*-S-SV]

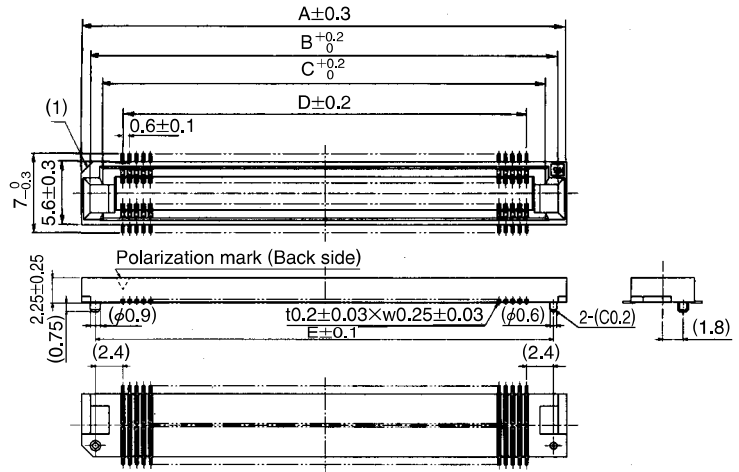
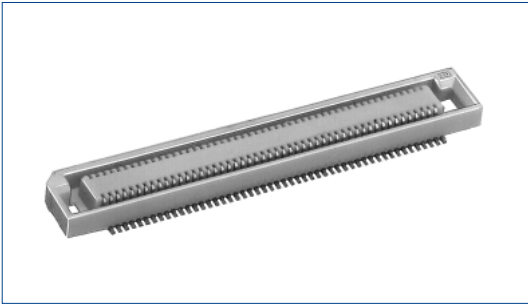

Unit : mm

Part No.**	HRS No.	No. of contacts	A	B	C	D	E	RoHS
FX8-60S-SV(**)	578-0201-5 **	60	24.60	23.05	20.80	17.40	22.20	Yes
FX8-80S-SV(**)	578-0203-0 **	80	30.60	29.05	26.80	23.40	28.20	
FX8-90S-SV(**)	578-0204-3 **	90	33.60	32.05	29.80	26.40	31.20	
FX8-100S-SV(**)	578-0205-6 **	100	36.60	35.05	32.80	29.40	34.20	
FX8-120S-SV(**)	578-0206-9 **	120	42.60	41.05	38.80	35.40	40.20	
FX8-140S-SV(**)	578-0207-1 **	140	48.60	47.05	44.80	41.40	46.20	

\*\* None : Tray packaging, 21 : Tube packaging, 22 : Embossed tape packaging

Note 1 : Please place orders in full magazine/tube quantities.

Note 2 : Reels are sold containing 1,000 pcs/reel. Please refer to the delivery form on page 6 for details.

Note 3 : Please note that tray packaged parts are not suitable for use with automatic mounting processes.

## ◆ PCB Mounting Pattern

### Header

[FX8-\*\*-P-SV]  
[FX8-\*\*-P-SV1]

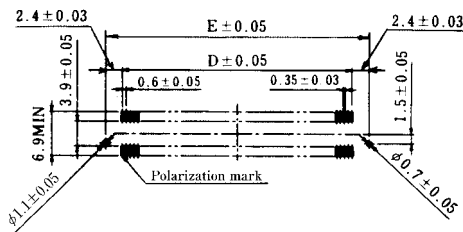

• Recommended metal mask thickness : t = 0.15mm

### Receptacle

[FX8-\*\*-S-SV]

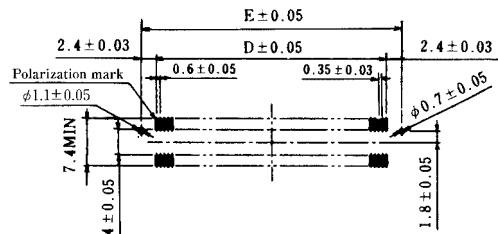

- Recommended metal mask thickness : t = 0.15mm
- If the inside (the connector mounting lower side) of the SMT portion is not treated with the insulation tape and so on, the area is specified as a pattern prohibited area.



## ◆ Connector Precautions for use

### 1. Tolerance Clearance on the Mating Side

The effective contact length of the product is set to 0.7mm. Please make sure there is less than 0.2mm clearance between the header and receptacle during mating.

### 2. Support between the PCBs

Please be sure to fix the boards to each other with screws or other means of support. Do not use only the mated connector to support the boards.

### 3. Stacking Height Tolerance for Mating

Stack 3mm	3 $\begin{smallmatrix} +0.3 \\ -0.2 \end{smallmatrix}$ mm
Stack 4mm	4 $\begin{smallmatrix} +0.3 \\ -0.2 \end{smallmatrix}$ mm

Note : Please Note that the above stacking tolerance doesn't include the solder paste thickness.

### 4. Multiple mounting on same PCB is not recommended in principle

### 5. Mounting Temperature Profile (Reference)

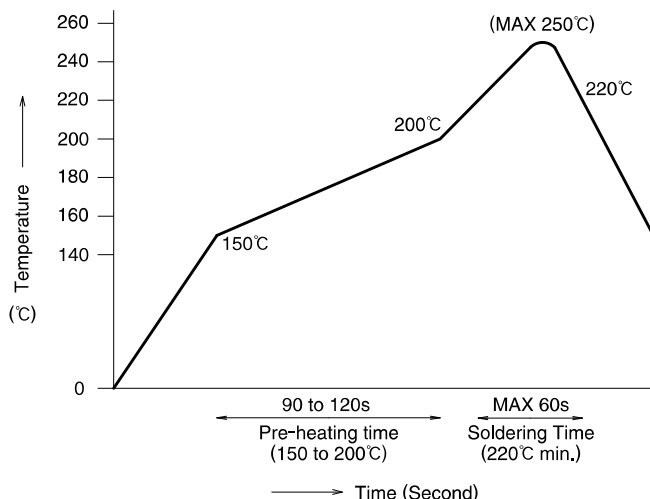

#### HRS test conditions

Test board Glass epoxy 161mm×100mm×1.6mm thick  
 Solder method : Reflow  
 Solder composition : Paste, 96.5%Sn/3%Ag/0.5%Cu  
 Metal mask : 0.15mm thick  
 Reflow cycles : 2 cycles

The temperature profile is based on the above conditions.

In individual applications the actual temperature may vary, depending on solder paste type, volume/thickness and board size/thickness. Consult your solder paste and equipment manufacturer for specific recommendations.

## ◆ Packaging Type

Packaging Type	No. of contacts	60 contacts	80 contacts	90 contacts	100 contacts	120 contacts	140 contacts
Tube packaging	Pieces per tube	21 pcs	17 pcs	15 pcs	14 pcs	12 pcs	10 pcs
	Sales unit	Per tube. Please place orders in full magazine/tube quantities.					
	Tube Total Length	550mm±2mm					
Embossed Tape Packaging	Tape Width	44mm	44mm	44mm	56mm	56mm	72mm
	Product Pitch	12mm					
	Embossed Reel diameter	Refer to the table on catalog page 6.					
	Pieces per reel	1000 pcs/reel					
	Sales unit	Per reel					

\*\* The chart above applies only to individual connectors.  
Dual connected products are packaged and shipped in trays only.

## ◆ Packaging Specification

### [Tube packaging]

#### ● Header

[FX8-\*\*-P-SV (91)]

[FX8-\*\*-P-SV1 (91)]

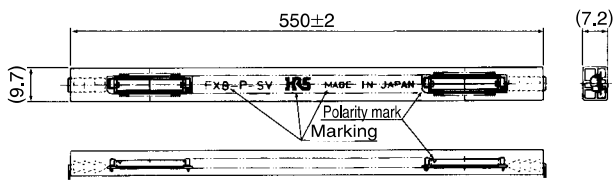

#### ● Receptacle

[FX8-\*\*-S-SV (21)]

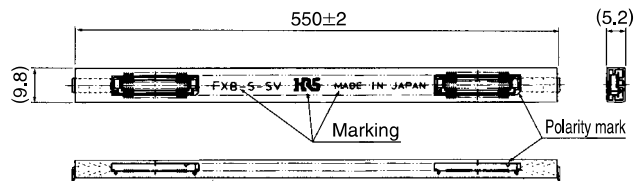

### [Embossed Tape Package]

#### ● Embossed Carrier Tape Dimensions

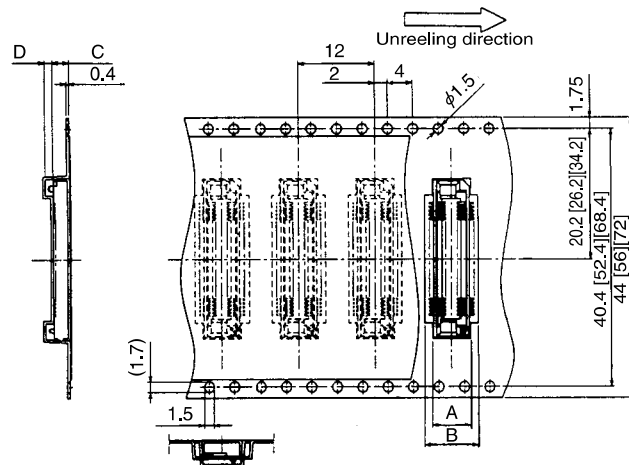

#### ● Reel Dimensions (FREE)

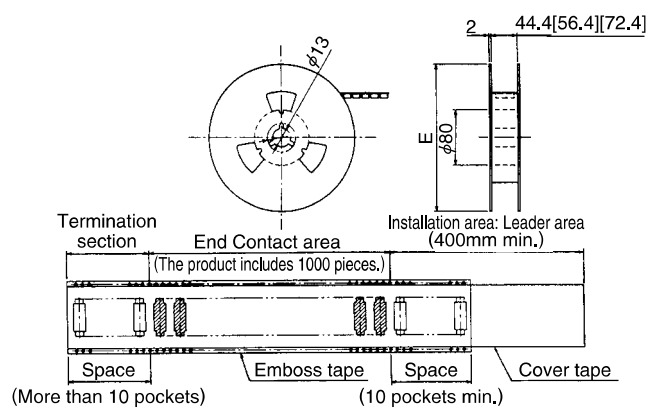

\*The figure above shows the receptacle in its pocket.

P/S	Part No.	A	B	C	D	E
Header	FX8-**-P-SV (92)	5.5	7.9	3.2	12	φ 330
	FX8-**-P-SV1 (92)			4.2		(Note 1)
Receptacle	FX8-**-S-SV (22)	6.0	8.4	2.6		φ 330

\*\* : No. of contacts

Note 1 : φ 330 are for 60, 80 and 90 contacts.

φ 360 are for 100, 120 and 140 contacts.

## FX8C Series

### Product Specifications

Ratings	Rated current : 0.4A	Operation temperature range : -55 to +85°C (Note 1)	Storage temperature range : -10 to +60°C (Note 2)
	Rated voltage : AC 100V	Operation humidity range : 40 to 80%	Storage humidity range : 40 to 70% (Note 2)

Items	Specifications	Conditions
1. Insulation resistance	Min of 100M $\Omega$	Measured at 250 V DC
2. Withstand voltage	No flashover or dielectric breakdown.	300V AC for 1 minute
3. Contact resistance	Max of 80M $\Omega$	Measured at 100 mA
4. Vibration proof	No electrical discontinuity lasting for a min of 1 $\mu$ s.	10 to 55Hz, half amplitude : 0.75mm, 3 axis directions, 10 cycles each.
5. Moisture resistance	Contact resistance : a max of 100m $\Omega$ ; Insulation resistance : a min of 100M $\Omega$	Left for 96 hours at the temperature of 40 $\pm$ 2°C and the humidity of 90 to 95%
6. Temperature cycle	Contact resistance : a max of 100m $\Omega$ ; Insulation resistance : a min of 100 $\Omega$	(-55°C for 30 minutes $\rightarrow$ 15 to 35°C for 2 to 3 minutes $\rightarrow$ 85°C for 30 minutes $\rightarrow$ 15 to 35°C for 2 to 3 minutes) in 5 cycles
7. Mating cycles	Contact resistance : a max of 100m $\Omega$	50 times
8. Soldering heat resistance	No dissolution of the resin affecting performance.	Reflow : With recommended temperature profile, at the soldering iron temperature of 350°C for 5 seconds

Note 1 : Includes the temperature rise caused by current flow.

Note 2 : Storage as described here represents the long-term-storage status of unused items before they are mounted on PCB.  
Operation humidity range applies to the unpowered status after the items are mounted on PCB.

Note 3 : The contact resistance noted above is measured using a connector combination with a 16mm stack height.

### Material / Finish

Part name	Material	Treatment		Remarks
Insulator	PPS resin	Light brown		UL94V-0
Header contact	Phosphor bronze	Contact area	Gold plating	_____
		Lead area	Pure tin plating (Note 2)	
Receptacle contact		Contact area	Gold plating	_____
		Lead area	Pure tin plating (Note 2)	

Note 1 : Black dots or other color irregularities may occur in the insulator resin. In addition, the color may change if exposed to sunlight or florescent light. But this does not affect the quality or performance.

Note 2 : FX8C-*\*P-SV* (*\**) and FX8C-*\*S-SV* are gold plated.

### Product Number Structure

Refer to the chart below when determining the product specifications from the product number.

Please select from the product numbers listed in this catalog when placing orders.

#### Single Product

**FX8C - 120 P - SV 1 (91)**

①                  ②        ③                  ④    ⑤        ⑥

① Series name : FX8C	⑤ Variable product height : None : Standard (Minimum height product) 1 : +1mm    6 : +6mm
② No. of contacts : 60, 80, 100, 120, 140	⑥ Packaged state (71) : Tray packaging (68), (91) : Magazine/tube packaging (92) : Embossed tape packaging (93) : Vacuum tape, embossed tape packaging
③ Connector type : P : Header S : Receptacle	
④ Contact form : SV : Vertical PCB type	

#### Two-connected products

**FX8C - 120/120 P 11 - SV 1 J**

①                  ②                  ③    ④                  ⑤    ⑥        ⑦

① Series name : FX8C	④ Pitch between dual connected products
② No. of contacts : 60 $\times$ 2, 80 $\times$ 2, 100 $\times$ 2, 120 $\times$ 2, 140 $\times$ 2 Example : 120/120=240 contacts	⑤ Contact form : SV : Vertical PCB type
	⑥ Variable product height : None : Standard (Minimum height product) 1 : +1mm    6 : +6mm
	⑦ J : Dual connected product
③ Connector type : P : Header S : Receptacle	

\*Dual connected products are packed in trays as the standard delivery method.



### Stacking Height Variations

Header \ Receptacle	FX8C-**-S-SV FX8C-**-**S11-SVJ	FX8C-**-S-SV5 FX8C-**-**S11-SV5J
FX8C-**-P-SV FX8C-**-**P11-SVJ	5mm	10mm
FX8C-**-P-SV1 FX8C-**-**P11-SV1J	6mm	11mm
FX8C-**-P-SV2 FX8C-**-**P11-SV2J	7mm	12mm
FX8C-**-P-SV4 FX8C-**-**P11-SV4J	9mm	14mm
FX8C-**-P-SV6 FX8C-**-**P11-SV6J	11mm	16mm

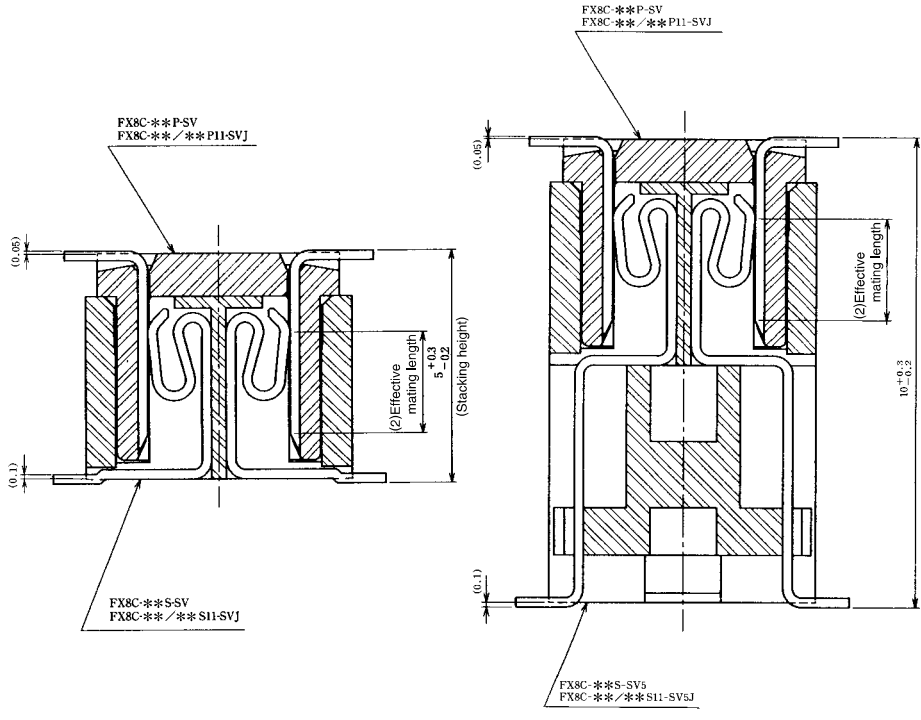
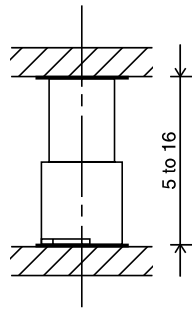

Nov.1.2018 Copyright 2018 HIROSE ELECTRIC CO., LTD. All Rights Reserved.



**Header (Single Product)**

**[FX8C-\*\*-P-SV]**

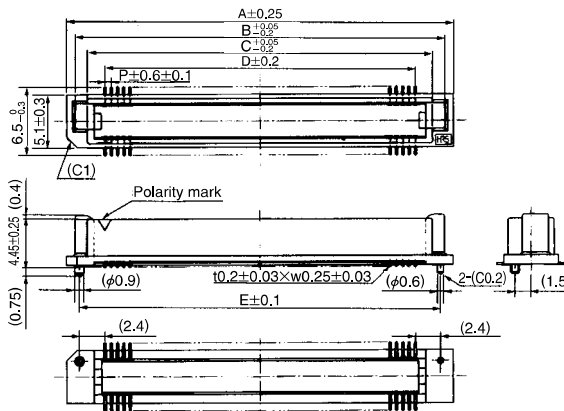
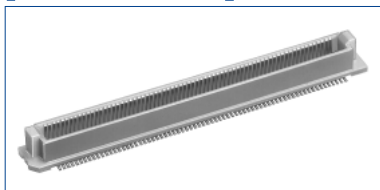

Unit : mm

Part No.	HRS No.	No. of contacts	A	B	C	D	E	RoHS
FX8C-60P-SV(**)	578-0501-9 **	60	24.60	23.00	20.70	17.40	22.20	Yes
FX8C-80P-SV(**)	578-0503-4 **	80	30.60	29.00	26.70	23.40	28.20	
FX8C-100P-SV(**)	578-0505-0 **	100	36.60	35.00	32.70	29.40	34.20	
FX8C-120P-SV(**)	578-0506-2 **	120	42.60	41.00	38.70	35.40	40.20	
FX8C-140P-SV(**)	578-0507-5 **	140	48.60	47.00	44.70	41.40	46.20	

Note 1 : Embossed tape packaging product are sold in full reel quantities. For details, see the item showing delivery forms in Page 16.

Note 2 : Please place orders in full magazine/tube quantities.

Note 3 : Please note that tray packaged parts are not suitable for use with automatic mounting processes.

**[FX8C-\*\*-P-SV1]**

**[FX8C-\*\*-P-SV2]**

**[FX8C-\*\*-P-SV4]**

**[FX8C-\*\*-P-SV6]**

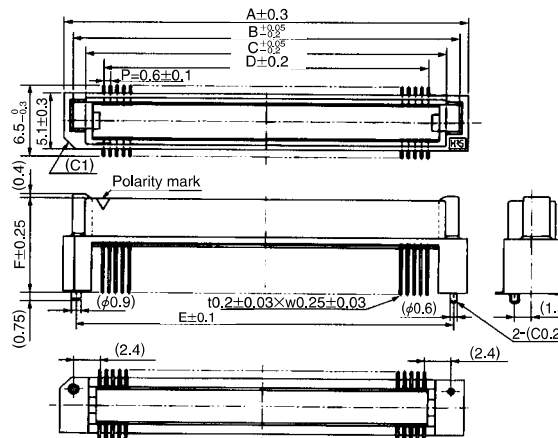
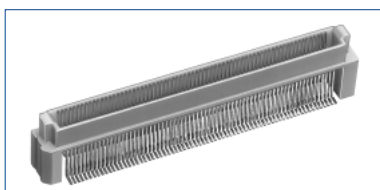

Unit : mm

Part No.	HRS No.	No. of contacts	A	B	C	D	E	F	RoHS
FX8C-60P-SV1(**)	578-0521-6 **	60	24.60	23.00	20.70	17.40	22.20	5.45	Yes
FX8C-60P-SV2(**)	578-0541-3 **							6.45	
FX8C-60P-SV4(**)	578-0581-8 **							8.45	
FX8C-60P-SV6(**)	578-0601-3 **							10.45	
FX8C-80P-SV1(**)	578-0523-1 **	80	30.60	29.00	26.70	23.40	28.20	5.45	
FX8C-80P-SV2(**)	578-0543-9 **							6.45	
FX8C-80P-SV4(**)	578-0583-3 **							8.45	
FX8C-80P-SV6(**)	578-0603-9 **							10.45	
FX8C-100P-SV1(**)	578-0525-7 **	100	36.60	35.00	32.70	29.40	34.20	5.45	
FX8C-100P-SV2(**)	578-0545-4 **							6.45	
FX8C-100P-SV4(**)	578-0585-9 **							8.45	
FX8C-100P-SV6(**)	578-0605-4 **							10.45	
FX8C-120P-SV1(**)	578-0526-0 **	120	42.60	41.00	38.70	35.40	40.20	5.45	
FX8C-120P-SV2(**)	578-0546-7 **							6.45	
FX8C-120P-SV4(**)	578-0586-1 **							8.45	
FX8C-120P-SV6(**)	578-0606-7 **							10.45	
FX8C-140P-SV1(**)	578-0527-2 **	140	48.60	47.00	44.70	41.40	46.20	5.45	
FX8C-140P-SV2(**)	578-0547-0 **							6.45	
FX8C-140P-SV4(**)	578-0587-4 **							8.45	
FX8C-140P-SV6(**)	578-0607-0 **							10.45	

Note 1 : Embossed tape packaging product are sold in full reel quantities. For details, see the item showing delivery forms in Page 16.

Note 2 : Please place orders in full magazine/tube quantities.

Note 3 : For FX8C-\*\*-P-SV6 connectors, there is a spacer attached between the leads. Please request the specific drawing for clarification.

Note 4 : Please note that tray packaged parts are not suitable for use with automatic mounting processes.

### ■ Receptacle (Single Product)

#### [FX8C-\*\*-S-SV]

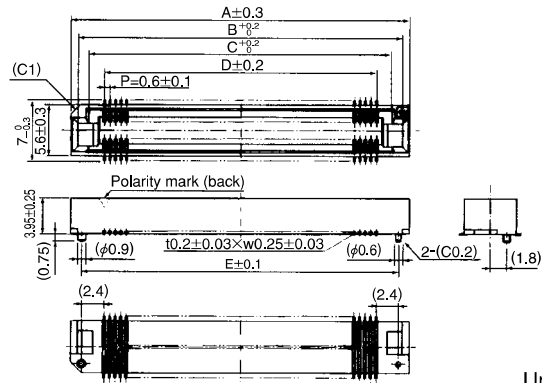
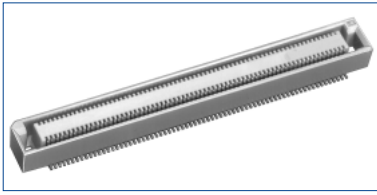

Unit : mm

Part No.	HRS No.	No. of contacts	A	B	C	D	E	RoHS
FX8C-60S-SV(**)	578-0801-2 **	60	24.60	23.05	20.80	17.40	22.20	Yes
FX8C-80S-SV(**)	578-0803-8 **	80	30.60	29.05	26.80	23.40	28.20	
FX8C-100S-SV(**)	578-0805-3 **	100	36.60	35.05	32.80	29.40	34.20	
FX8C-120S-SV(**)	578-0806-6 **	120	42.60	41.05	38.80	35.40	40.20	
FX8C-140S-SV(**)	578-0807-9 **	140	48.60	47.05	44.80	41.40	46.20	

Note 1 : Embossed tape packaging product are sold in full reel quantities. For details, see the item showing delivery forms in Page 16.

Note 2 : Please place orders in full magazine/tube quantities.

Note 3 : Please note that tray packaged parts are not suitable for use with automatic mounting processes.

#### [FX8C-\*\*-S-SV5]

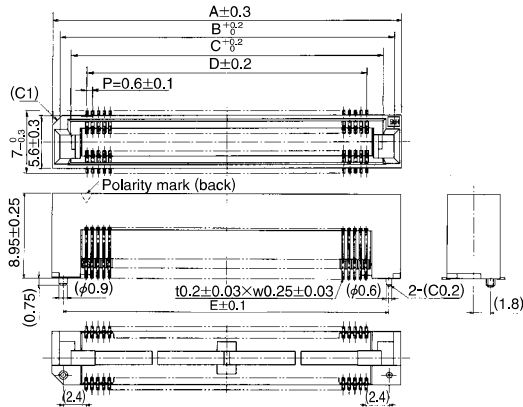
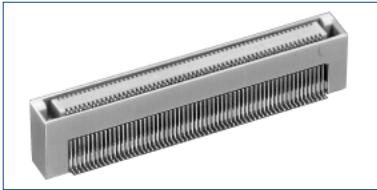

Unit : mm

Part No.	HRS No.	No. of contacts	A	B	C	D	E	RoHS
FX8C-60S-SV5(**)	578-0821-0 **	60	24.6	23.05	20.8	17.4	22.2	Yes
FX8C-80S-SV5(**)	578-0823-5 **	80	30.6	29.05	26.8	23.4	28.2	
FX8C-100S-SV5(**)	578-0825-0 **	100	36.6	35.05	32.8	29.4	34.2	
FX8C-120S-SV5(**)	578-0826-3 **	120	42.6	41.05	38.8	35.4	40.2	
FX8C-140S-SV5(**)	578-0827-6 **	140	48.6	47.05	44.8	41.4	46.2	

Note 1 : Embossed tape packaging product are sold in full reel quantities.

For details, see the item showing delivery forms in Page 16.

Note 2 : Please place orders in full magazine/tube quantities.

Note 3 : Please note that tray packaged parts are not suitable for use with automatic mounting processes.

### ◆ Recommended PCB layout and metal mask dimensions for single connector (mounting side)

#### Header

##### [FX8C-\*\*-P-SV\*]

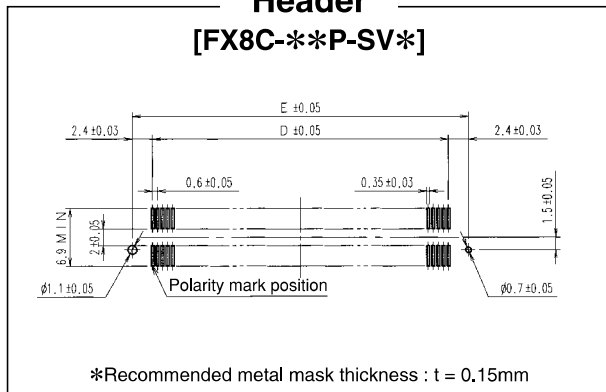

#### Receptacle

##### [FX8C-\*\*-S-SV, SV5\*]

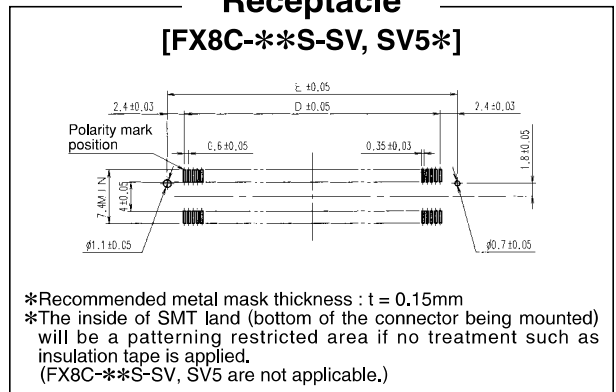

■ Header (Dual Connected Product)

[FX8C-\*/\*/\*\*P11-SVJ]

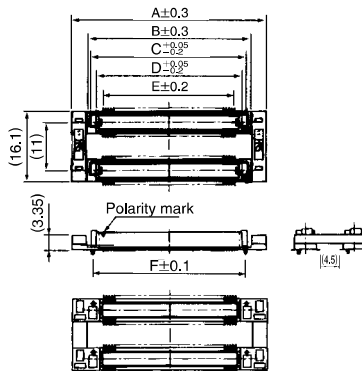
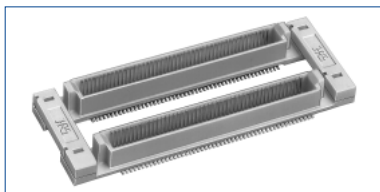

Unit : mm

Part No.	HRS No.	No. of contacts	A	B	C	D	E	F	RoHS
FX8C-60/60P11-SVJ(71)	578-0651-1 71	60x2	31.70	24.70	23.00	20.70	17.40	22.20	Yes
FX8C-80/80P11-SVJ(71)	578-0653-7 71	80x2	37.70	30.70	29.00	26.70	23.40	28.20	
FX8C-100/100P11-SVJ(71)	578-0655-2 71	100x2	43.70	36.70	35.00	32.70	29.40	34.20	
FX8C-120/120P11-SVJ(71)	578-0656-5 71	120x2	49.70	42.70	41.00	38.70	35.40	40.20	
FX8C-140/140P11-SVJ(71)	578-0657-8 71	140x2	55.70	48.70	47.00	44.70	41.40	46.20	

Note : Dual connected products are packaged and shipped in trays. And as such, are not suitable for use with automatic mounting processes.

[FX8C-\*/\*/\*\*P11-SV1J]

[FX8C-\*/\*/\*\*P11-SV2J]

[FX8C-\*/\*/\*\*P11-SV4J]

[FX8C-\*/\*/\*\*P11-SV6J]

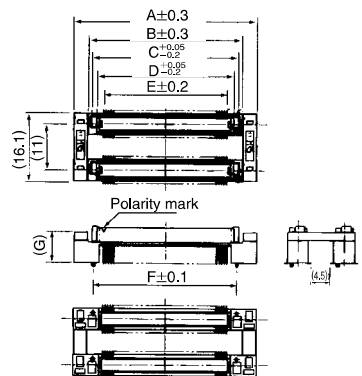
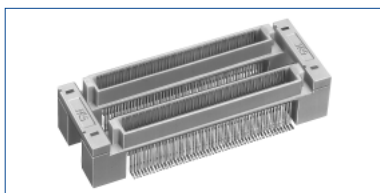

Unit : mm

Part No.	HRS No.	No. of contacts	A	B	C	D	E	F	G	H	RoHS
FX8C-60/60P11-SV1J(71)	578-0671-9 71	60x2	31.70	24.70	23.00	20.70	17.40	22.20	4.35	5.45	Yes
FX8C-60/60P11-SV2J(71)	578-0691-6 71								5.35	6.45	
FX8C-60/60P11-SV4J(71)	578-0731-9 71								7.35	8.45	
FX8C-60/60P11-SV6J(71)	578-0751-6 71								9.35	10.45	
FX8C-80/80P11-SV1J(71)	578-0673-4 71	80x2	37.70	30.70	29.00	26.70	23.40	28.20	4.35	5.45	
FX8C-80/80P11-SV2J(71)	578-0693-1 71								5.35	6.45	
FX8C-80/80P11-SV4J(71)	578-0733-4 71								7.35	8.45	
FX8C-80/80P11-SV6J(71)	578-0753-1 71								9.35	10.45	
FX8C-100/100P11-SV1J(71)	578-0675-0 71	100x2	43.70	36.70	35.00	32.70	29.40	34.20	4.35	5.45	
FX8C-100/100P11-SV2J(71)	578-0695-7 71								5.35	6.45	
FX8C-100/100P11-SV4J(71)	578-0735-0 71								7.35	8.45	
FX8C-100/100P11-SV6J(71)	578-0755-7 71								9.35	10.45	
FX8C-120/120P11-SV1J(71)	578-0676-2 71	120x2	49.70	42.70	41.00	38.70	35.40	40.20	4.35	5.45	
FX8C-120/120P11-SV2J(71)	578-0696-0 71								5.35	6.45	
FX8C-120/120P11-SV4J(71)	578-0736-2 71								7.35	8.45	
FX8C-120/120P11-SV6J(71)	578-0756-0 71								9.35	10.45	
FX8C-140/140P11-SV1J(71)	578-0677-5 71	140x2	55.70	48.70	47.00	44.70	41.40	46.20	4.35	5.45	
FX8C-140/140P11-SV2J(71)	578-0697-2 71								5.35	6.45	
FX8C-140/140P11-SV4J(71)	578-0737-5 71								7.35	8.45	
FX8C-140/140P11-SV6J(71)	578-0757-2 71								9.35	10.45	

Note 1 : Dual connected products are packaged and shipped in trays. And as such, are not suitable for use with automatic mounting processes.

Note 2 : For FX8C-\*/\*/\*\*P11-SV6J connectors, there is a spacer attached between the leads. Please request the specific drawing for clarification.

## ■ Receptacle (Dual Connected Product)

### [FX8C-\*/\*/\*\*S11-SVJ]

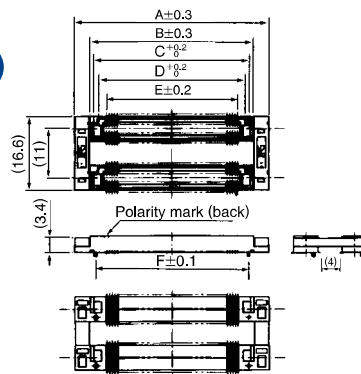
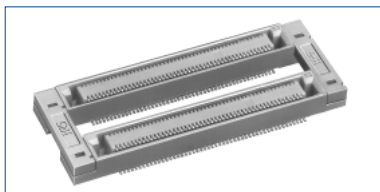

Unit : mm

Part No.	HRS No.	No. of contacts	A	B	C	D	E	F	RoHS
FX8C-60/60S11-SVJ(71)	578-0901-7 71	60×2	31.70	24.60	23.05	20.80	17.40	22.20	Yes
FX8C-80/80S11-SVJ(71)	578-0903-2 71	80×2	37.70	30.60	29.05	26.80	23.40	28.20	
FX8C-100/100S11-SVJ(71)	578-0905-8 71	100×2	43.70	36.60	35.05	32.80	29.40	34.20	
FX8C-120/120S11-SVJ(71)	578-0906-0 71	120×2	49.70	42.60	41.05	38.80	35.40	40.20	
FX8C-140/140S11-SVJ(71)	578-0907-3 71	140×2	55.70	48.60	47.05	44.80	41.40	46.20	

Note : Dual connected products are packaged and shipped in trays. And as such, are not suitable for use with automatic mounting processes.

### [FX8C-\*/\*/\*\*S11-SV5J]

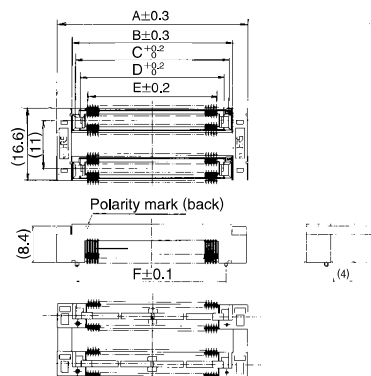

Unit : mm

Part No.	HRS No.	No. of contacts	A	B	C	D	E	F	RoHS
FX8C-60/60S11-SV5J(71)	578-0921-4 71	60×2	31.70	24.60	23.05	20.80	17.40	22.20	Yes
FX8C-80/80S11-SV5J(71)	578-0923-0 71	80×2	37.70	30.60	29.05	26.80	23.40	28.20	
FX8C-100/100S11-SV5J(71)	578-0925-5 71	100×2	43.70	36.60	35.05	32.80	29.40	34.20	
FX8C-120/120S11-SV5J(71)	578-0926-8 71	120×2	49.70	42.60	41.05	38.80	35.40	40.20	
FX8C-140/140S11-SV5J(71)	578-0927-0 71	140×2	55.70	48.60	47.05	44.80	41.40	46.20	

Note : Dual connected products are packaged and shipped in trays. And as such, are not suitable for use with automatic mounting processes.

## ◆ Recommended PCB layout and metal mask dimensions for dual connected products (mounting side)

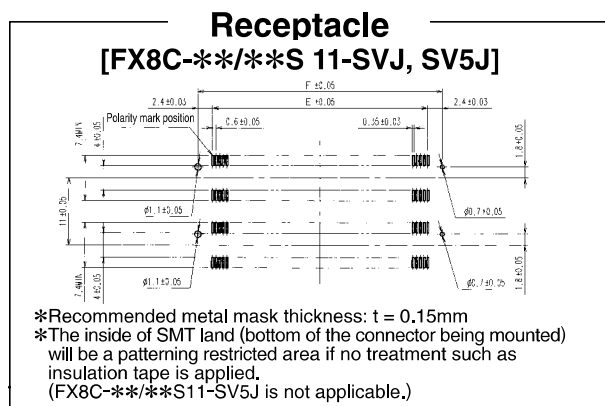
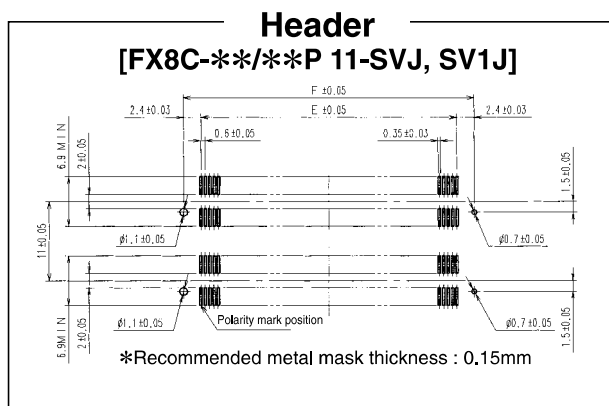

◆ Detailed drawing on dual connected products after the spacers are removed (individual connector from dual connected product)

Header

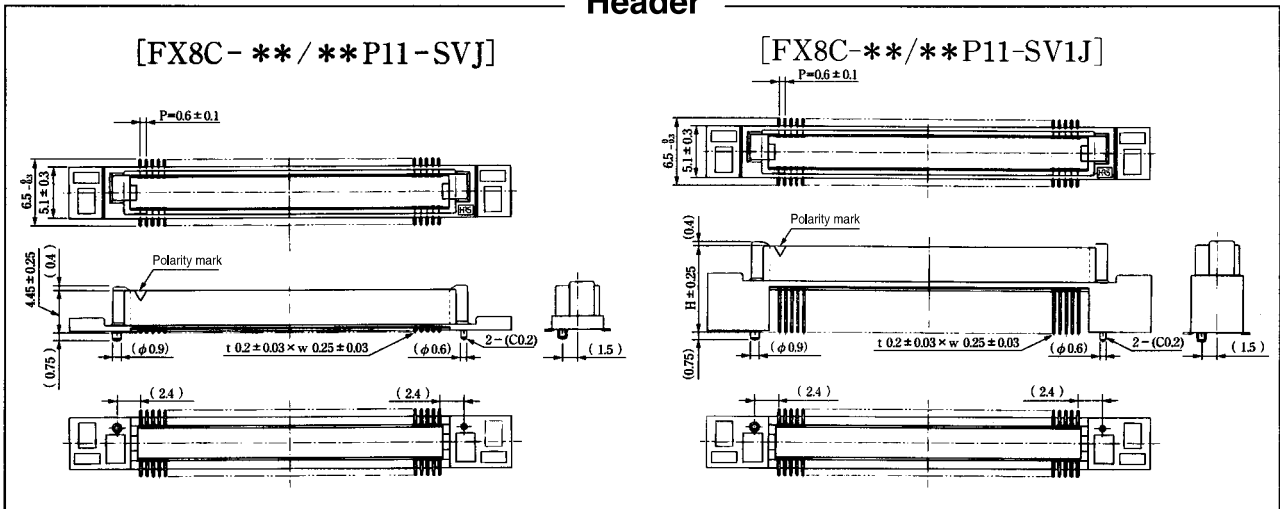

Receptacle

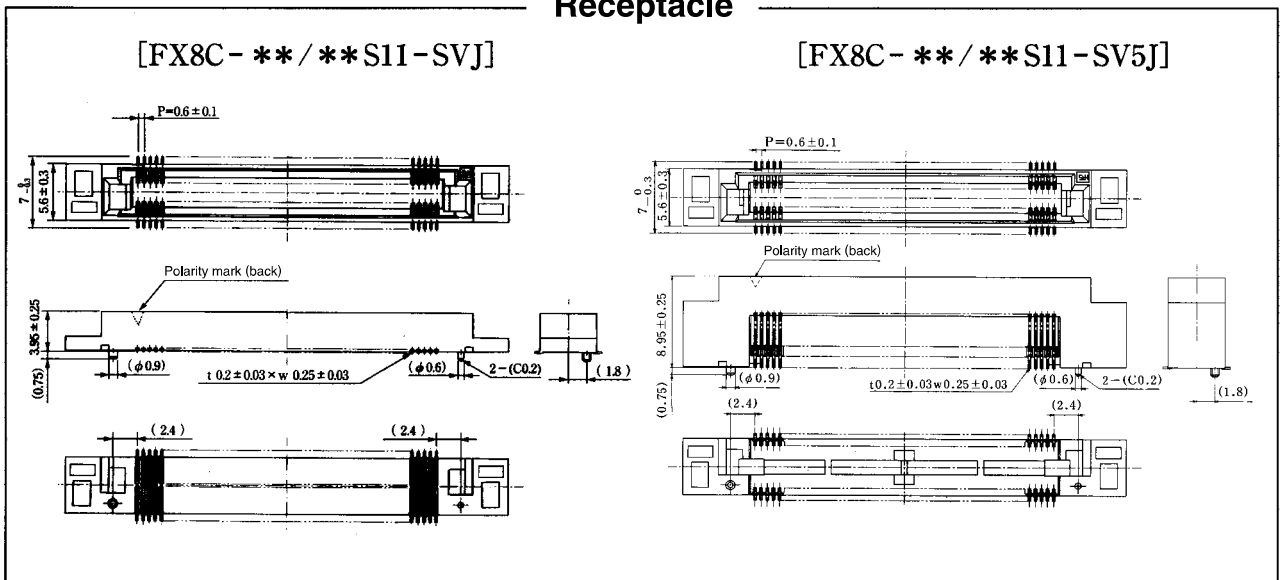

## ◆ How to Use the Connector

### 1. Permissible gap between mating surfaces

The effective mating length of this product is 2.0mm. Please make sure that the gap between the header and receptacle when mated will be 1.2mm or less.

### 2. Fixation between mounted PCBs

If the connector is secured to the board with only other connectors, please make sure that no vibrations or impact will occur.

### 3. Tolerances in stacking height when mated

Stack    Amm     $\longrightarrow$     A  $\begin{matrix} +0.3 \\ -0.2 \end{matrix}$  mm

Note: Please note that the thickness of solder cream is not taken into account for the above tolerances in stacking height.

### 4. Using dual connected products

Dual connected products are fixed with spacers on both longitudinal sides. However, the products cannot be mated in that state. Please make sure to remove the spacers before mating. (Please do not remove the spacers before mounting on PCB.)

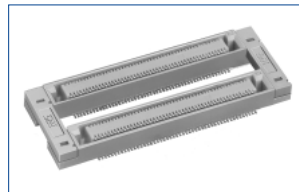
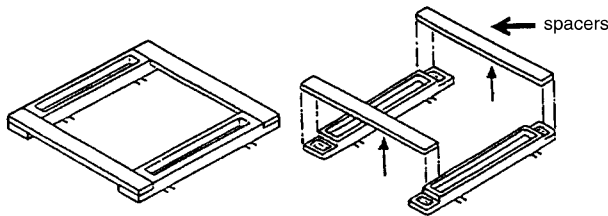

Before removing the joint bar

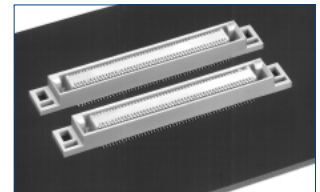

After removing the joint bar

Note : Please use dual-connected products for multiple mounting.  
However, multiple mounting of dual-connected products are not recommended.

### 5. Temperature profile for mounting (reference)

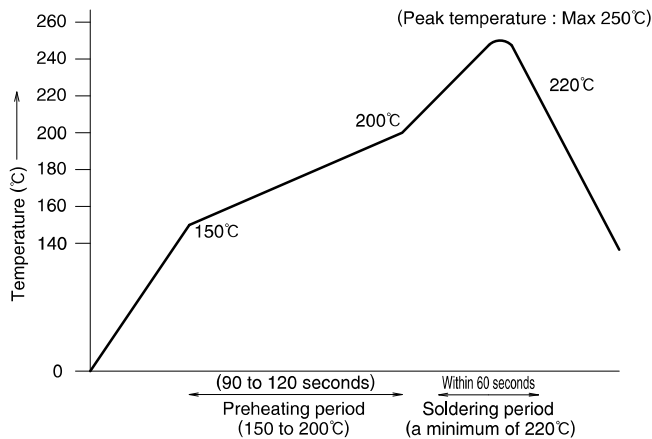

#### <Applicable conditions>

Reflow method	Reflow with infrared light and heat (SENSBEY NR-II)
Environment in the reflow furnace	Ambient air
Solder	Cream type (Sn-3Ag-0.5Cu) (Flux contained amount : 11 Wt%) (M705-221CM5-42-10.5 manufactured by Senju Metal Industry Co., Ltd.)
PCB	Size 161 × 100 × 1.6mm Material : Glass epoxy
Metal mask thickness	Thickness : 0.15mm

Note 1 : This temperature profile shows recommended values.  
Temperature should be measured on the top of the connector.

Note 2 : The reflow process should be limited to two times.

Note 3 : Results may differ depending on the type and manufacturer of solder cream, PCB size, mounting materials and other conditions. Please be sure to confirm the mounting conditions before use.

### 6. Usage Recommendations

This product has been thin-formed for minimization.  
Care should be taken that excessive prying mating/unmating could cause damage and contact failure.

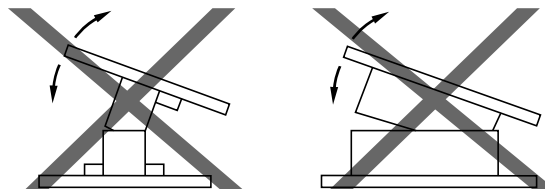



### ◆ Form of Delivery

Packaging style	No. of contacts	60 contacts	80 contacts	100 contacts	120 contacts	140 contacts
Magazine packaging	Product quantity	21 pieces	17 pieces	14 pieces	12 pieces	10 pieces
	Sales unit	Please place orders in full magazine/tube quantities.				
	Overall magazine length	550mm ± 2mm				
Embossed tape packaging	Tape width (JIS)	44		56		72
	Product pitch	(12mm)				
	Embossed reel diameter	Please see the table shown in Page 16 of this catalog.				
	Product quantity	Please see the table shown in Page 16 of this catalog.				
	Sales unit	Full reels. Please see the table shown in page 16 of this catalog.				

\*\*The chart above applies only to individual connectors.  
Dual connected products will be packaged and delivered in trays.

### ◆ Packaging Specification

#### [Magazine Packaging]

##### ● Header

- [FX8C-\*\*\*P-SV(91)]
- [FX8C-\*\*\*P-SV1(91)]
- [FX8C-\*\*\*P-SV2(91)]
- [FX8C-\*\*\*P-SV4(91)]
- [FX8C-\*\*\*P-SV6(91)]

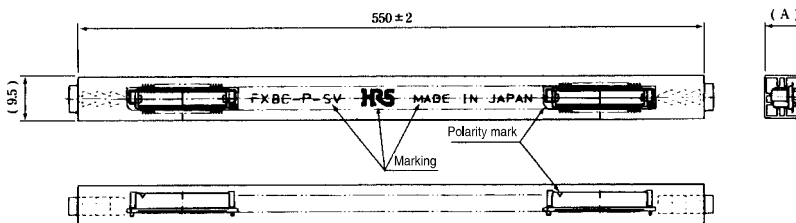

##### ● Receptacle

- [FX8C-\*\*\*S-SV(68)]
- [FX8C-\*\*\*S-SV5(91)]

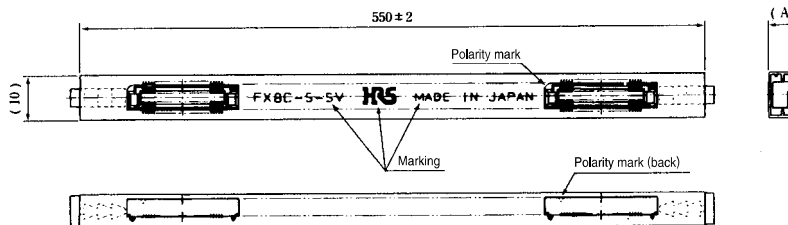

P/S	Part No.	A
Header	FX8C-***P-SV(91)	9
	FX8C-***P-SV1(91)	10
	FX8C-***P-SV2(91)	11
	FX8C-***P-SV4(91)	13
	FX8C-***P-SV6(91)	15
Receptacle	FX8C-***S-SV(68)	7.4
	FX8C-***S-SV5(91)	12.4



[Embossed Tape Packaging]

●Carrier Dimensions

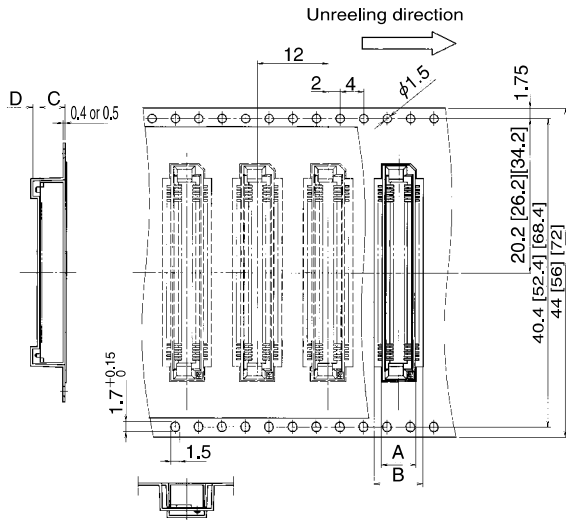

●Reel Dimensions

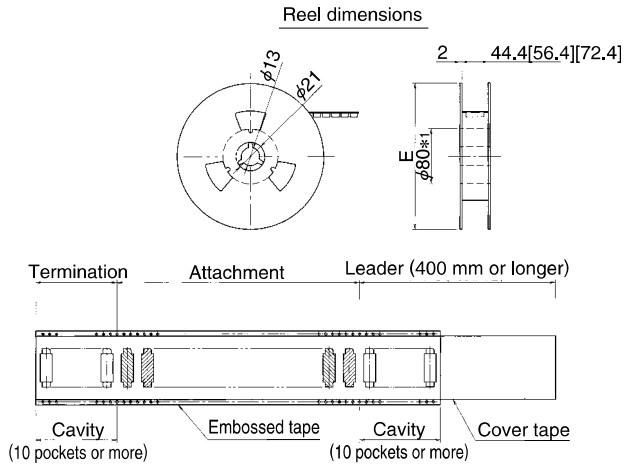

\*The figure above shows FX8 receptacles packaged on an embossed tape. Dimensions shown in brackets [ ] are those for tape widths of 56mm or 72mm.

\*1 For FX8C-140S-SV(92), E dimension is 370 in diameter and core dimension is 100 in diameter.

\*2 For FX8C-120P-SV2(92), FX8C-120S-SV5(92), and FX8C-140S-SV5(92), E dimension is 380 in diameter.

Note : Some products are not available packaged on an embossed tape. Please be sure to clarify the packaging type before you order.

Unit : mm

P/S	Part No.	A	B	C	D	E	Product quantity
Header	FX8C-***P-SV(92)	5.5	7.9	5.2	1.2	φ370	1000 pcs/reel
	FX8C-***P-SV1(92)	5.5	7.9	6.2	1.2	φ370	1000 pcs/reel
	FX8C-***P-SV2(92)	5.5	7.9	7.2	1.2	φ330	500 pcs/reel *2
	FX8C-***P-SV4(92)	5.5	7.9	9.2	1.2	φ370	500 pcs/reel
	FX8C-***P-SV6(92)	5.5	7.9	11.2	1.2	φ370	500 pcs/reel
Receptacle	FX8C-***S-SV(92)	6.0	8.4	4.3	1.2	φ330	1000 pcs/reel *1
	FX8C-***S-SV5(92)	6.0	8.4	9.3	1.2	φ370	500 pcs/reel *2

\*\* : No. of contacts



**HIROSE ELECTRIC CO.,LTD.**

2-6-3,Nakagawa Chuoh,Tsuzuki-Ku,Yokohama-Shi 224-8540,JAPAN

TEL: +81-45-620-3526 Fax: +81-45-591-3726

<http://www.hirose.com>

<http://www.hirose-connectors.com>