

Technical Data
Data Sheet N1595 Rev. -

Adjustable Precision Shunt Regulator

Description:

The SMC431, TL431A and TL431 are 3-terminal adjustable precision shunt regulators with guaranteed temperature stability over the applicable extended commercial temperature range. The output voltage may be set at any level greater than 2.495V (VREF) up to 30V merely by selecting two external resistors that act as a voltage divider network. These devices have a typical output impedance of 0.08Ω. Active output circuitry provides a very sharp turn-on characteristic, making these devices excellent improved replacements for zener diodes in many applications. The precise ±0.5% reference voltage tolerance of the SMC431 makes it possible in many applications to avoid the use of a variable resistor, consequently saving cost and eliminating drift and reliability problems associated with it.

Features:

- Precision Reference Voltage.
SMC431 : 2.495V ±0.5%
TL431A : 2.495V ±1.0%
TL431 : 2.495V ±1.6%
- Sink Current Capability: 200mA.
- Minimum Cathode Current for Regulation: 250µA.
- Equivalent Full-Range Temperature Coefficient: 50 ppm/°C.
- Fast Turn-On Response.
- Low Dynamic Output Impedance: 0.08Ω.
- Adjustable Output Voltage.
- Low Output Noise.
- Space Saving Packages: SOT-23

Applications:

- Linear Regulators.
- Adjustable Supplies.
- Switching Power Supplies.
- Battery Operated Computers.
- Instrumentation.
- Computer Disk Drivers.

Typical application circuit:

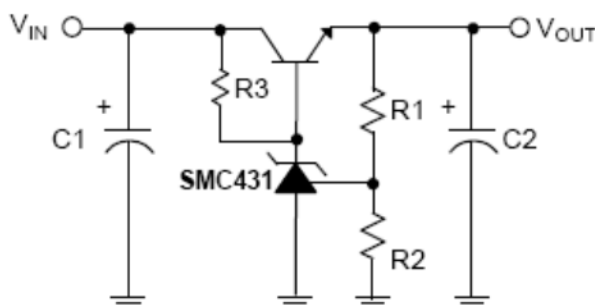

$$V_{OUT} = (1 + R1/R2) V_{REF}$$

Precision Regulator

- China - Germany - Korea - Singapore - United States •
- <http://www.smc-diodes.com> - sales@smc-diodes.com •



SMC431
TL431
TL431A

Technical Data
Data Sheet N1595 Rev. -

Adjustable Precision Shunt Regulator

Ordering Information:

SMC431 -XXX
SMC431-XXX
TL431A -XXX

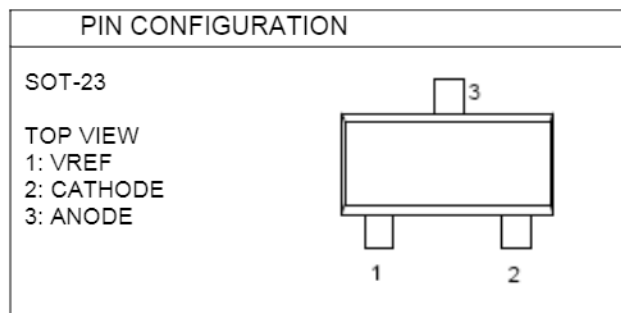
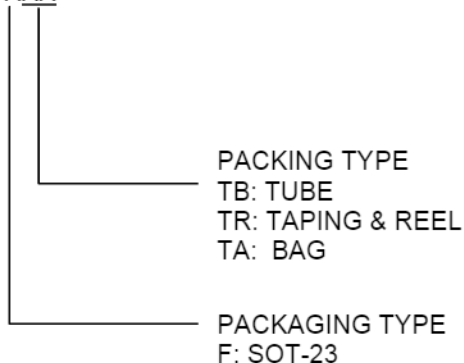

Marking Diagram:

Part No.	Marking
SMC431FTA	AC1SG
TL431FTA	AC2SG
TL431AFTA	AC3SG

Absolute Maximum Ratings:

Cathode Voltage.....30V
 Continuous Cathode Current..... -10mA~250mA
 Reference Input Current Range.....10mA
 Operating Temperature Range -40°C to 85°C
 Storage Temperature Range-65°C ~ 150°C
 Maximum Junction Temperature125°C
 Lead Temperature (Soldering) 10 sec.260°C

Absolute Maximum Ratings are those values beyond which the life of a device may be impaired.

Test Circuit

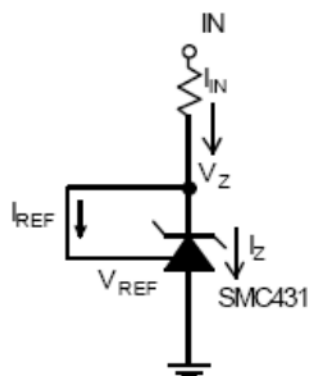

Fig. 1 Test Circuit for $V_Z = V_{REF}$

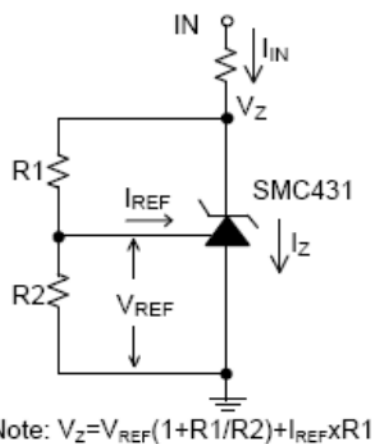

Fig. 2 Test Circuit for $V_Z > V_{REF}$

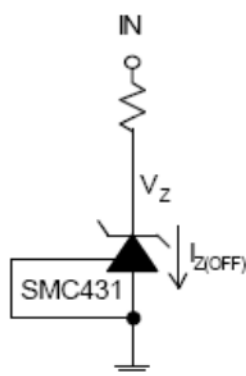
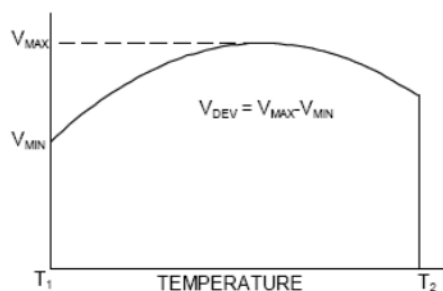

Fig. 3 Test Circuit for off-state Current

Electrical Characteristics (T_A=25°C, unless otherwise specified.) (Note 1)

PARAMETER	TEST CONDITIONS	SYMBOL	MIN.	TYP.	MAX.	UNIT
Reference Voltage	V _Z =V _{REF} , I _{IN} =10mA (Fig. 1)	SMC431	2.482	2.495	2.508	V
		TL431A	2.470	2.495	2.520	
		TL431	2.455	2.495	2.535	
Deviation of Reference Input Voltage Over Temperature (Note 2)	V _Z = V _{REF} , I _{IN} =10mA, T _A = 0°C~ +70°C (Fig. 1) T _A = -40°C~ +85°C (Fig. 1)	V _{DEV}		9.0	20	mV
				9.0	50	
Ratio of the Change in Reference Voltage to the Change in Cathode voltage	I _Z =10mA (Fig. 2)	ΔV _Z =10V-V _{REF}		-0.5	-2.0	mV/V
		ΔV _Z =30V-10V		-0.35	-1.5	mV/V
Reference Input Current	R1 =10KΩ, R2=∞, I _{IN} =10mA (Fig. 2)	I _{REF}		0.8	3.5	μA
Deviation of Reference Input Current over Temperature	R1 =10KΩ, R2=∞, I _{IN} =10mA T _A =-40°C ~ +85°C (Fig. 2)	αI _{REF}		0.3	1.2	μA
Minimum Cathode current for Regulation	V _Z =V _{REF} (Fig. 1)	I _{Z(MIN)}		0.25	0.5	mA
Off-State Current	V _Z =20V, V _{REF} =0V (Fig. 3)	I _{Z(OFF)}		0.1	1.0	μA
Dynamic Output Impedance (Note 3)	V _Z =V _{REF} F<1KHz (Fig. 1)	R _Z		0.08	0.3	Ω

Note 1: Specifications are production tested at T_A=25°C. Specifications over the -40°C to 85°C operating temperature range are assured by design, characterization and correlation with Statistical Quality Controls (SQC).



Note 2: Deviation of reference input voltage, V_{DEV}, is defined as the maximum variation of the reference input voltage over the full temperature range.

The average temperature coefficient of the reference input voltage, αV_{REF} is defined as:

$$\Delta V_{REF} \frac{\text{ppm}}{^{\circ}\text{C}} = \frac{\pm \left[\frac{V_{MAX} - V_{MIN}}{V_{REF}(\text{at } 25^{\circ}\text{C})} \right] 10^6}{T_2 - T_1} = \pm \left[\frac{V_{DEV}}{V_{REF}(\text{at } 25^{\circ}\text{C})} \right] \frac{1}{T_2 - T_1}$$

Where:

T₂-T₁=full temperature change.

αV_{REF} can be positive or negative depending on whether the slope is positive or negative.

Example: V_{DEV}= 9.0mV, V_{REF}= 2495mV,

T₂-T₁= 70°C, slope is negative.

$$\alpha V_{REF} = \frac{\left[\frac{9.0\text{mV}}{2495\text{mV}} \right] 10^6}{70^{\circ}\text{C}} = -50\text{ppm}/^{\circ}\text{C}$$

Note 3: The dynamic output impedance, R_Z, is defined as:

$$R_Z = \frac{\Delta V_Z}{\Delta I_Z}$$

When the device is programmed with two external resistors, R1 and R2, (see Fig. 2), the dynamic output impedance of the overall circuit, is defined as:

$$r_Z = \frac{\Delta V}{\Delta I} \cong R_Z \left[1 + \frac{R_1}{R_2} \right]$$

Technical Data
Data Sheet N1595 Rev. -
Typical Performance Characteristics

Adjustable Precision Shunt Regulator

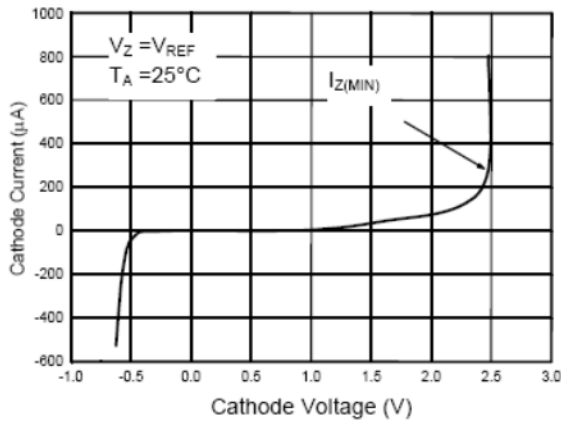

Fig. 4 Cathode Current vs. Cathode Voltage

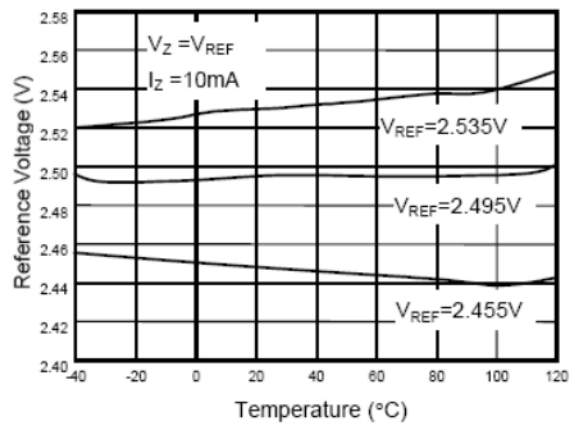

Fig. 5 Reference Voltage vs. Temperature

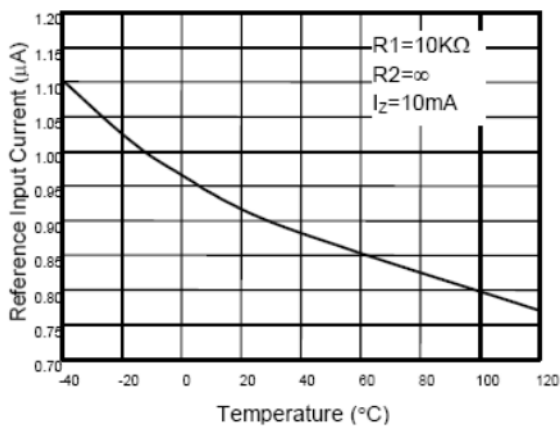

Fig. 6 Reference Input Current vs. Temperature

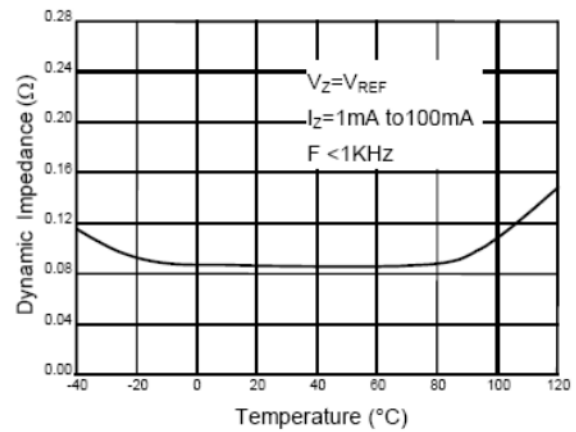

Fig. 7 Dynamic Impedance vs. Temperature

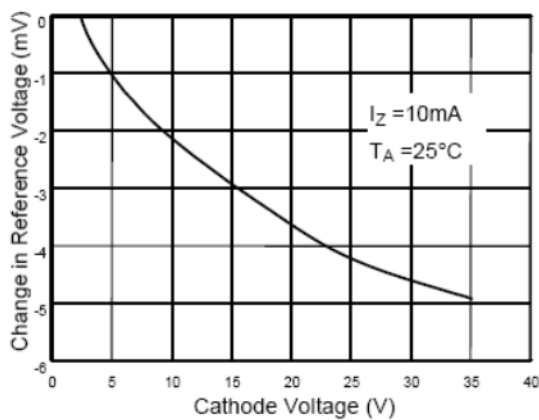

Fig. 8 Change in Reference Voltage vs. Cathode Voltage

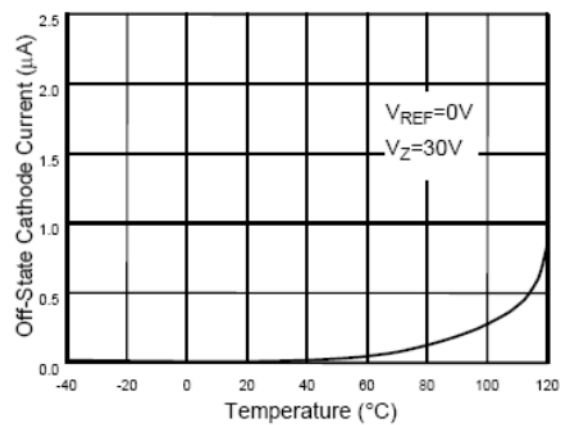

Fig. 9 Off-State Cathode Current vs. Temperature

Technical Data
Data Sheet N1595 Rev. -

Adjustable Precision Shunt Regulator

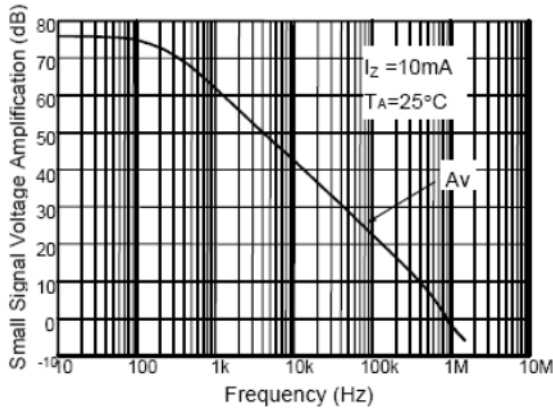

Fig. 10 Small Signal Voltage Amplification vs. Frequency

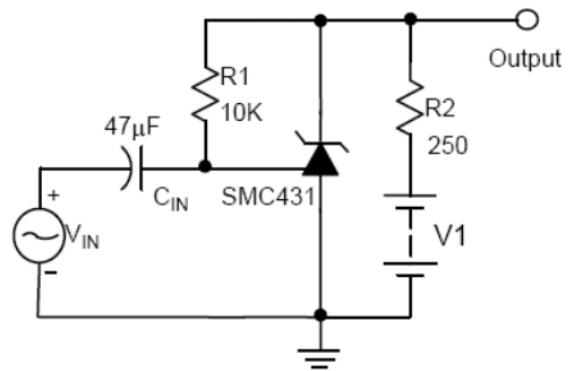

Fig. 11 Test Circuit For Frequency Response

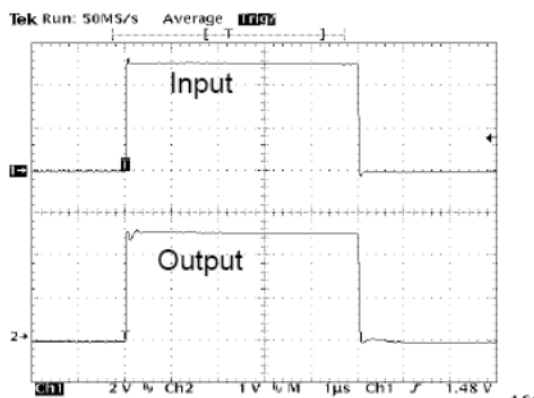

Fig. 12 Pulse Response

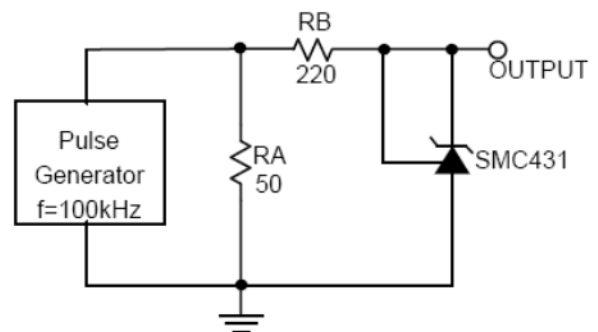

Fig. 13 Test Circuit For Pulse Response

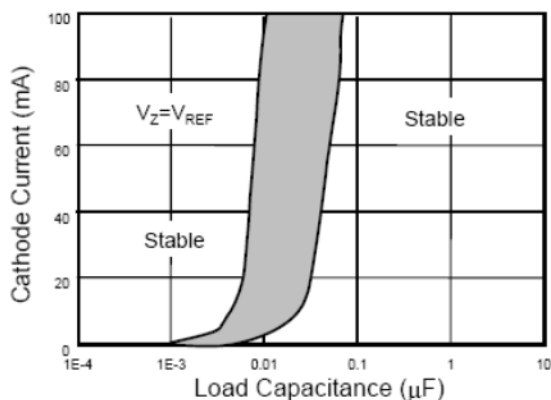

Fig. 14 Stability Boundary Conditions

The areas between the curves represent condition that may cause the device oscillate

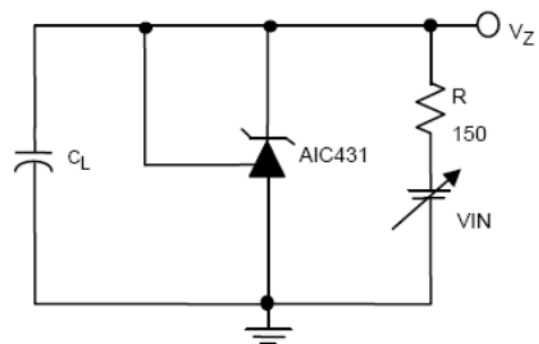

Fig. 15 Test Circuit for Stability Boundary

Technical Data
Data Sheet N1595 Rev. -

Adjustable Precision Shunt Regulator

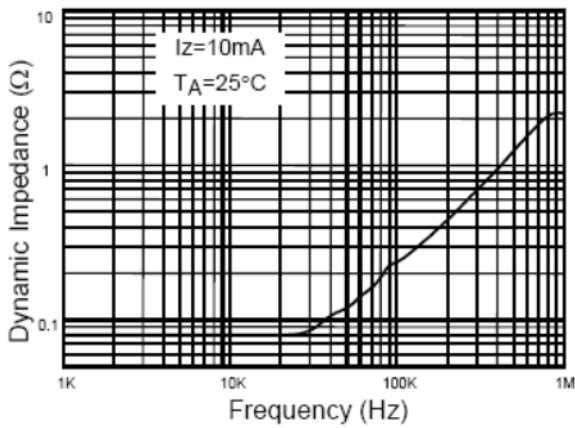

Fig. 16 Dynamic impedance vs. Frequency

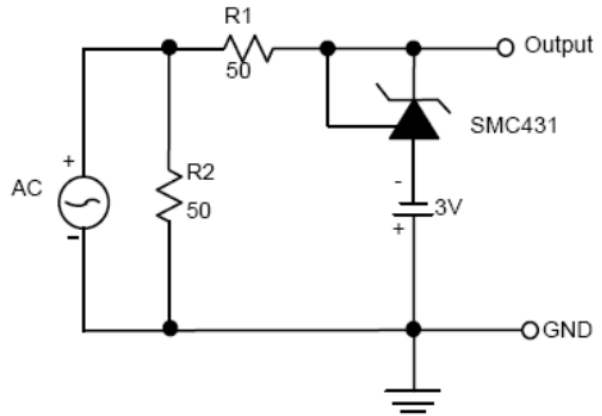
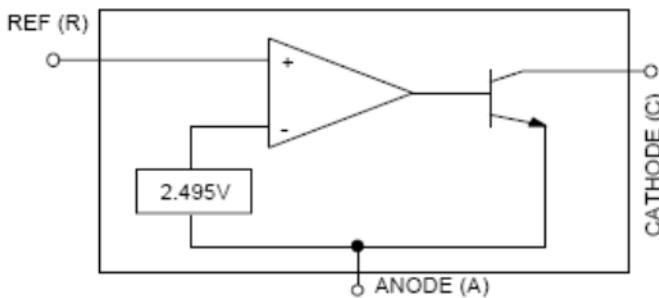
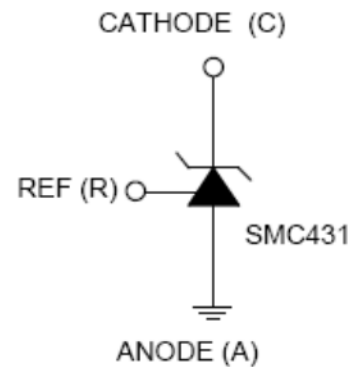

Fig. 17 Test Circuit for Dynamic Impedance

Block Diagram



Symbol



Pin Descriptions

- CATHODE Pin - Sinks current with a range from 250μA to 200mA for normal applications.
- VREF Pin - Providing VREF=2.495V (typ.) for adjustable output voltage.
- ANODE Pin - Anode pin sources current for normal application. The current value is the same as Cathode pin.

Technical Data
Data Sheet N1595 Rev. -
Application Examples

Adjustable Precision Shunt Regulator

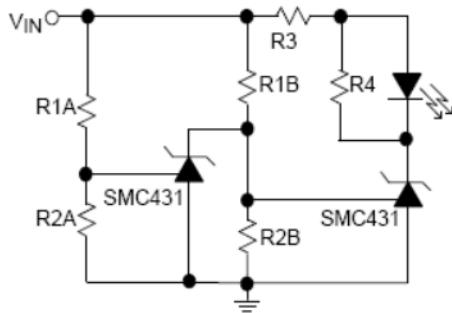

LED Turn on when Low Limit < V_{IN} < High Limit

Low Limit $\cong V_{REF} (1+R1B/R2B)$

High Limit $\cong V_{REF} (1+R1A/R2A)$

Fig. 18 Voltage Monitor

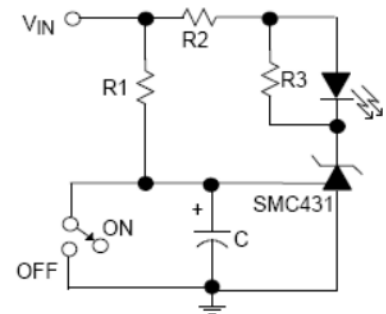

Delay = $R \times C \times \ln \left(\frac{V_{IN}}{V_{IN} - V_{REF}} \right)$

Fig. 19 Delay Timer

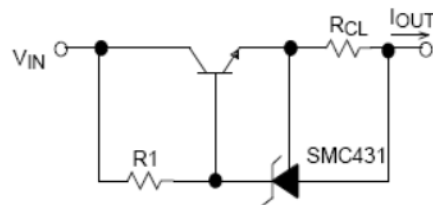

$I_{OUT} = V_{REF} / R_{CL}$

Fig. 20 Current Limiter or Current Source

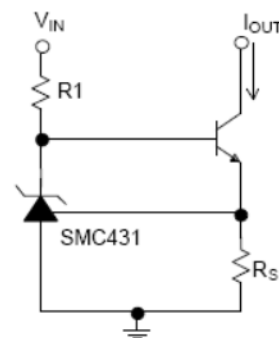

$I_{OUT} = V_{REF} / R_S$

Fig. 21 Constant-Current Sink

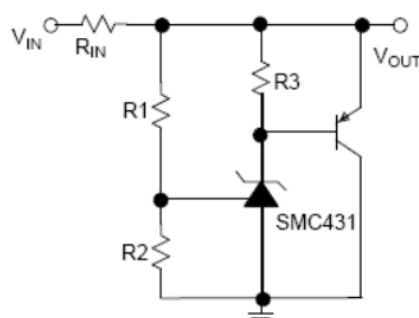

$V_{OUT} \cong (1+R1/R2) \times V_{REF}$

Fig. 22. Higher-Current Shunt Regulator

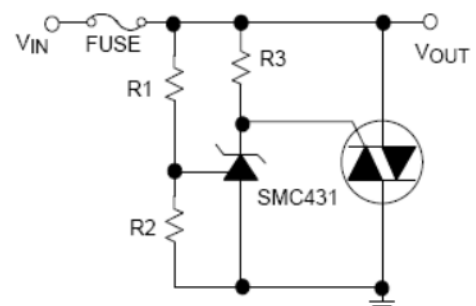

$V_{LIMIT} \cong (1+R1/R2) \times V_{REF}$

Fig. 23 Crow Bar

Application Examples (Continued)

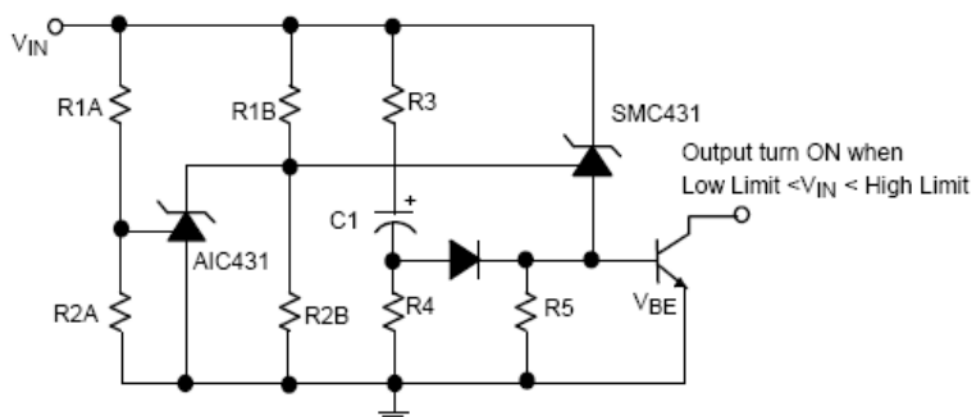

$$\text{Low Limit} \cong V_{REF} (1 + R1B / R2B) + V_{BE}$$

$$\text{High Limit} \cong V_{REF} (1 + R1A / R2A)$$

Fig 24. Over-Voltage/Under-Voltage Protection Circuit

Physical Dimensions

SOT-23 (unit: mm)

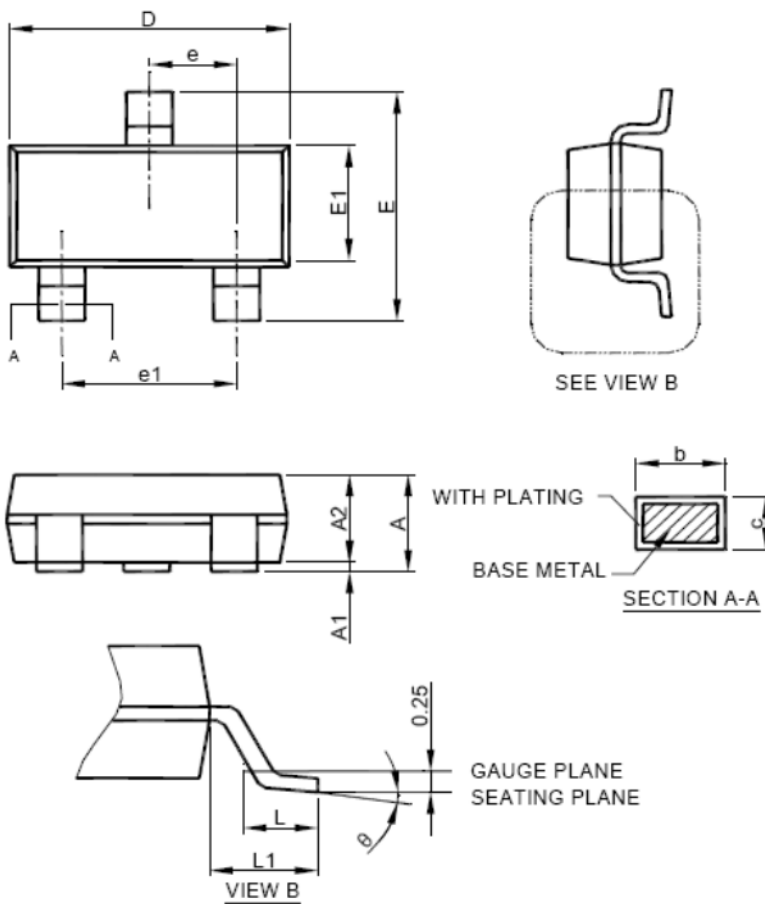

SYMBOL	SOT-23	
	MILLIMETERS	
	MIN.	MAX.
A	0.95	1.45
A1	0.00	0.15
A2	0.90	1.30
b	0.30	0.50
c	0.08	0.22
D	2.80	3.00
E	2.60	3.00
E1	1.50	1.70
e	0.95 BSC	
e1	1.90 BSC	
L	0.30	0.60
L1	0.60 REF	
θ	0°	8°

Note: 1. Refer to JEDEC MO-178.

2. Dimension "D" does not include mold flash, protrusions or gate burrs. Mold flash, protrusion or gate burrs shall not exceed 10 mil per side.

3. Dimension "E1" does not include inter-lead flash or protrusions.

4. Controlling dimension is millimeter, converted inch dimensions are not necessarily exact.



SMC431
TL431
TL431A

Technical Data
Data Sheet N1595 Rev. -

Adjustable Precision Shunt Regulator

DISCLAIMER:

- 1- The information given herein, including the specifications and dimensions, is subject to change without prior notice to improve product characteristics. Before ordering, purchasers are advised to contact the SMC - Sangdest Microelectronics (Nanjing) Co., Ltd sales department for the latest version of the datasheet(s).
- 2- In cases where extremely high reliability is required (such as use in nuclear power control, aerospace and aviation, traffic equipment, medical equipment, and safety equipment), safety should be ensured by using semiconductor devices that feature assured safety or by means of users' fail-safe precautions or other arrangement.
- 3- In no event shall SMC - Sangdest Microelectronics (Nanjing) Co., Ltd be liable for any damages that may result from an accident or any other cause during operation of the user's units according to the datasheet(s). SMC - Sangdest Microelectronics (Nanjing) Co., Ltd assumes no responsibility for any intellectual property claims or any other problems that may result from applications of information, products or circuits described in the datasheets.
- 4- In no event shall SMC - Sangdest Microelectronics (Nanjing) Co., Ltd be liable for any failure in a semiconductor device or any secondary damage resulting from use at a value exceeding the absolute maximum rating.
- 5- No license is granted by the datasheet(s) under any patents or other rights of any third party or SMC - Sangdest Microelectronics (Nanjing) Co., Ltd.
- 6- The datasheet(s) may not be reproduced or duplicated, in any form, in whole or part, without the expressed written permission of SMC - Sangdest Microelectronics (Nanjing) Co., Ltd.
- 7- The products (technologies) described in the datasheet(s) are not to be provided to any party whose purpose in their application will hinder maintenance of international peace and safety nor are they to be applied to that purpose by their direct purchasers or any third party. When exporting these products (technologies), the necessary procedures are to be taken in accordance with related laws and regulations..