

P.C.B LAYOUT

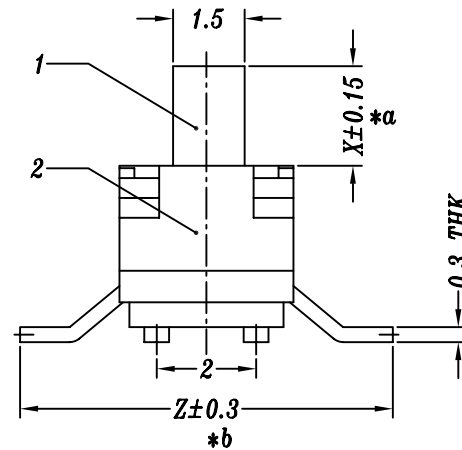
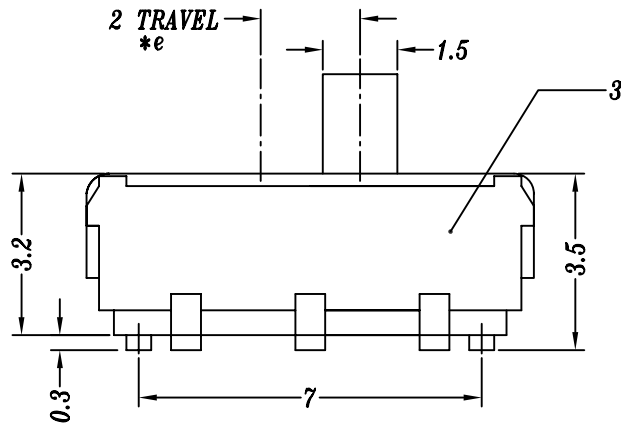
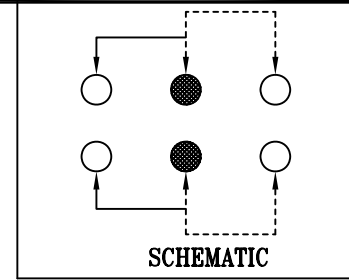

SPECIFICATION

1. Rating: DC 12V 0.3A
2. Travel: 2 mm
3. Function: 2P2T
4. Contact Resistance:  $\leq 70m\Omega$  MAX
5. Operating Force:  $130\pm 50gf$ ,  $200\pm 80gf$ ,  $300\pm 100gf$
6. Life test: 10,000 cycles

KNOB X=1.5, 2, 2.3, 3, 3.5, 4, 5, 6mm  
 TERMINAL Z=5.0 6.9 7.5 10.5mm

G2: 胶柄长3mm  
 B: 胶柄黑色

				TOLERANCE		A2	2017.09.29	新增胶柄高度规格		PWJ	
				UNLESS SPECIFIED		A1	2017.02.10	新增T6.9规格		GYW	
				UP TO 5mm: $\pm 0.1$	ANGULAR	A0	2016.12.30	首次发行		GYW	
				ABOVE 5mm: $\pm 0.2$	$\pm 1^\circ$	NO	DATE	REVISIONS		BY APPD	
4	MK22D10 SPRING	PBS	2	NATURAL	TITLE:MINI SLIDE SWITCH		UNIT : MM	ROHS	DWN		
3	MS22D17 CASE(MS-22D16)	PA6T/0.3mm BRASS STRIP	1	BLACK/Ag PLATED	MODEL:MS-22D17 G3-B 弹线		SCALE: 6:1	COMPLIANT	CHK'D		
2	MS22D16 COVER	0.15mm SUS	1	WASHING	<b>HAOYU(HONGKONG)LIMITED</b> 皓宇(香港)有限公司					APPD	
1	MS22D16 KNOB	PA6T	1	BLACK						PRO.AGL:	
NO.	PART NAME	MATERIAL	QTY	FINISHING							