

Features

- Enhancement mode
- Low on-resistance $R_{DS(on)}$ @ $V_{GS}=4.5\text{ V}$
- VitoMOS[®] II Technology
- 100% Avalanche test
- Pb-free lead plating; RoHS compliant



Part ID	Package Type	Marking	Packing
VSP003N06MS-G	PDFN5x6	003N06M	3000PCS/Reel

V_{DS}	60	V
$R_{DS(on),TYP@ V_{GS}=10\text{ V}}$	2.5	mΩ
$R_{DS(on),TYP@ V_{GS}=4.5\text{ V}}$	4.3	mΩ
I_D	125	A

PDFN5x6

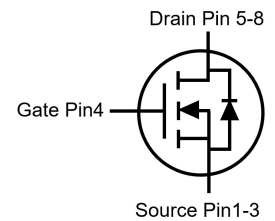
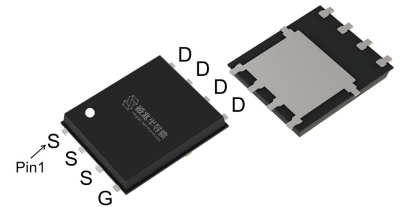

Maximum ratings, at $T_A=25^\circ\text{C}$, unless otherwise specified

Symbol	Parameter	Rating	Unit	
$V_{(BR)DSS}$	Drain-Source breakdown voltage	60	V	
V_{GS}	Gate-Source voltage	±20	V	
I_S	Diode continuous forward current	$T_C=25^\circ\text{C}$	125	A
I_D	Continuous drain current @ $V_{GS}=10\text{V}$	$T_C=25^\circ\text{C}$	125	A
		$T_C=100^\circ\text{C}$	79	A
I_{DM}	Pulse drain current tested ①	$T_C=25^\circ\text{C}$	500	A
I_{DSM}	Continuous drain current @ $V_{GS}=10\text{V}$	$T_A=25^\circ\text{C}$	31	A
		$T_A=70^\circ\text{C}$	24	A
EAS	Avalanche energy, single pulsed ②	100	mJ	
P_D	Maximum power dissipation	$T_C=25^\circ\text{C}$	69	W
P_{DSM}	Maximum power dissipation ③	$T_A=25^\circ\text{C}$	4.2	W
T_{STG}, T_J	Storage and Junction Temperature Range	-55 to 150	°C	

Thermal Characteristics

Symbol	Parameter	Typical	Unit
$R_{\theta JC}$	Thermal Resistance, Junction-to-Case	1.8	°C/W
$R_{\theta JA}$	Thermal Resistance, Junction-to-Ambient	30	°C/W

Electrical Characteristics

Symbol	Parameter	Condition	Min.	Typ.	Max.	Unit
Static Electrical Characteristics @ T_J=25°C (unless otherwise stated)						
V _{(BR)DSS}	Drain-Source Breakdown Voltage	V _{GS} =0V, I _D =250μA	60	--	--	V
I _{DSS}	Zero Gate Voltage Drain Current	V _{DS} =60V, V _{GS} =0V	--	--	1	μA
	Zero Gate Voltage Drain Current(T _J =125°C)	V _{DS} =60V, V _{GS} =0V	--	--	100	μA
I _{GSS}	Gate-Body Leakage Current	V _{GS} =±20V, V _{DS} =0V	--	--	±100	nA
V _{GS(TH)}	Gate Threshold Voltage	V _{DS} =V _{GS} , I _D =250μA	1.3	1.9	2.5	V
R _{DS(ON)}	Drain-Source On-State Resistance④	V _{GS} =10V, I _D =30A	--	2.5	3.5	mΩ
		T _J =100°C	--	3.2	--	mΩ
R _{DS(ON)}	Drain-Source On-State Resistance④	V _{GS} =4.5V, I _D =20A	--	4.3	6	mΩ
Dynamic Electrical Characteristics @ T_J = 25°C (unless otherwise stated)						
C _{iss}	Input Capacitance	V _{DS} =30V, V _{GS} =0V, f=1MHz	3020	3550	4080	pF
C _{oss}	Output Capacitance		1355	1595	1835	pF
C _{riss}	Reverse Transfer Capacitance		25	35	45	pF
R _g	Gate Resistance	f=1MHz	--	0.8	--	Ω
Q _g (10V)	Total Gate Charge	V _{DS} =30V, I _D =30A, V _{GS} =10V	--	48	--	nC
Q _g (4.5V)	Total Gate Charge		--	22	--	nC
Q _{gs}	Gate-Source Charge		--	11	--	nC
Q _{gd}	Gate-Drain Charge		--	5.2	--	nC
Switching Characteristics						
t _{d(on)}	Turn-on Delay Time	V _{DD} =30V, I _D =30A, R _G =3Ω, V _{GS} =10V	--	11	--	ns
t _r	Turn-on Rise Time		--	45	--	ns
t _{d(off)}	Turn-Off Delay Time		--	34	--	ns
t _f	Turn-Off Fall Time		--	32	--	ns
Source- Drain Diode Characteristics@ T_J = 25°C (unless otherwise stated)						
V _{SD}	Forward on voltage	I _{SD} =30A, V _{GS} =0V	--	0.8	1.2	V
t _{rr}	Reverse Recovery Time	T _J =25°C, I _{sd} =30A, V _{GS} =0V	--	53	--	ns
Q _{rr}	Reverse Recovery Charge	di/dt=100A/μs	--	51	--	nC

NOTE: ① Repetitive rating; pulse width limited by max junction temperature.

② Limited by T_{Jmax}, starting T_J = 25°C, L = 0.5mH, R_G = 25Ω, I_{AS} = 20A, V_{GS} = 10V. Part not recommended for use above this value

③ The power dissipation P_{DSM} is based on R_{θJA} and the maximum allowed junction temperature of 150°C.

④ Pulse width ≤ 380μs; duty cycles ≤ 2%.

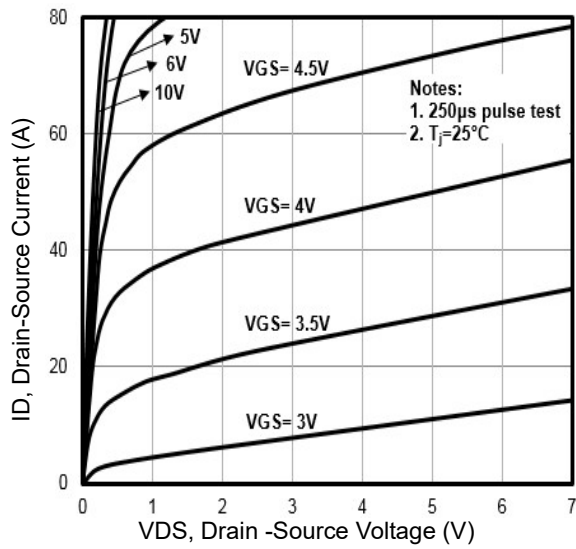
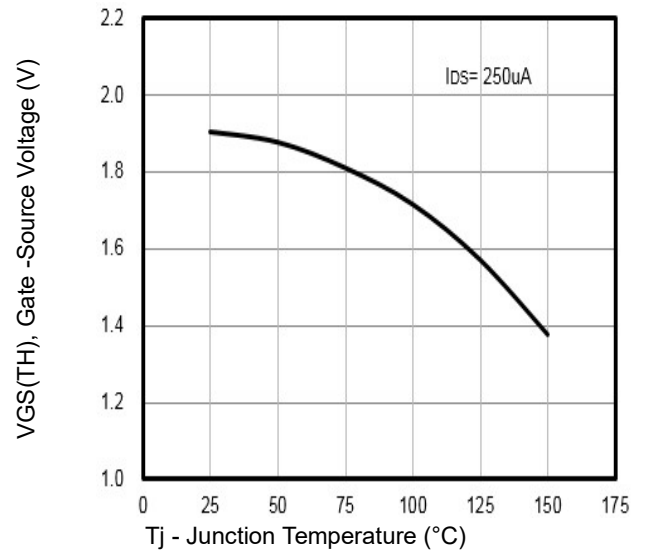
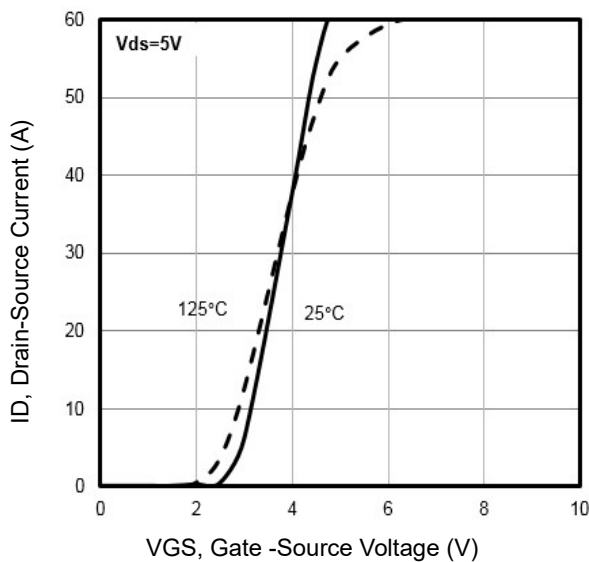
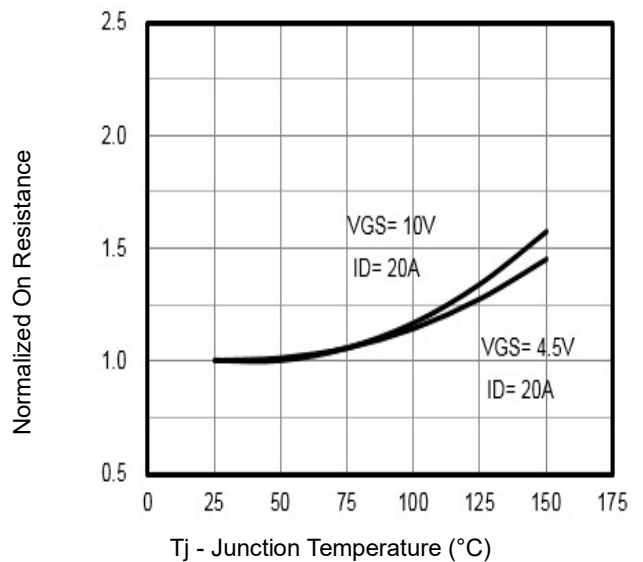
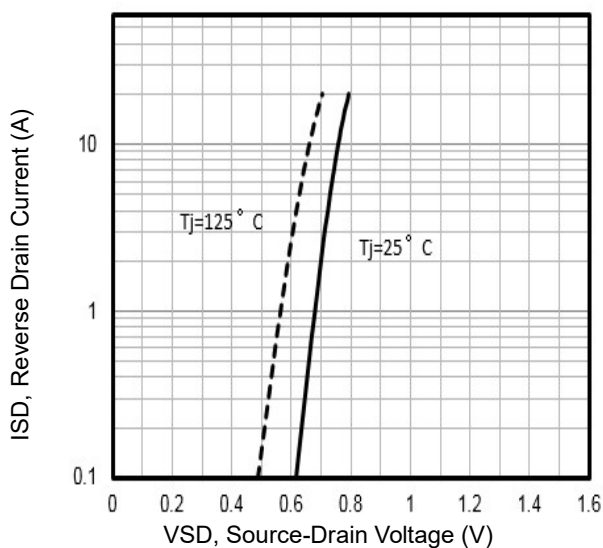
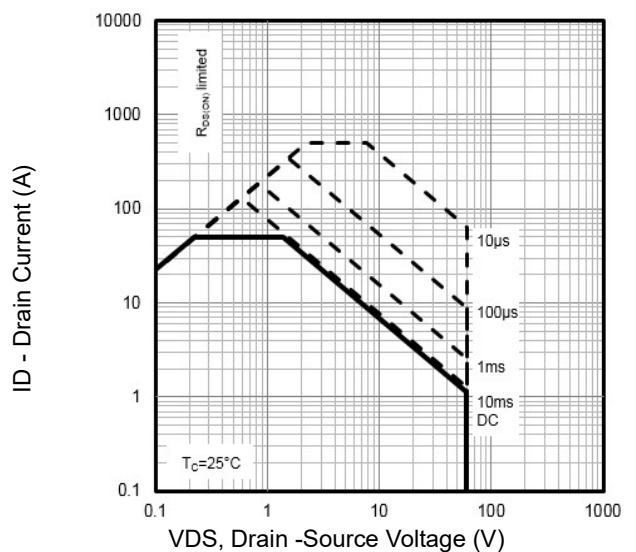
Typical Characteristics

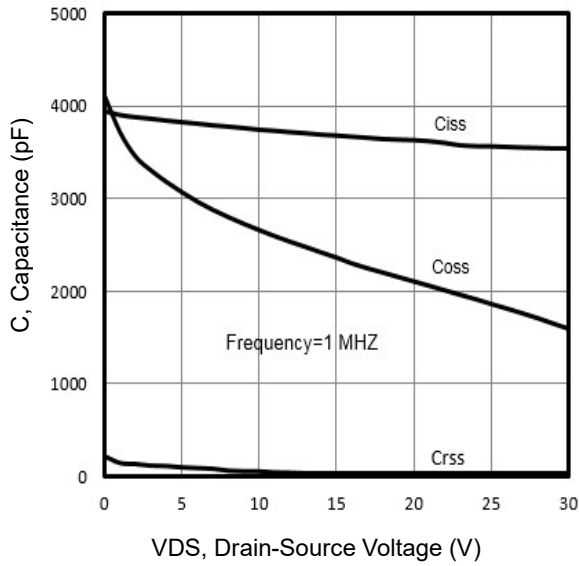
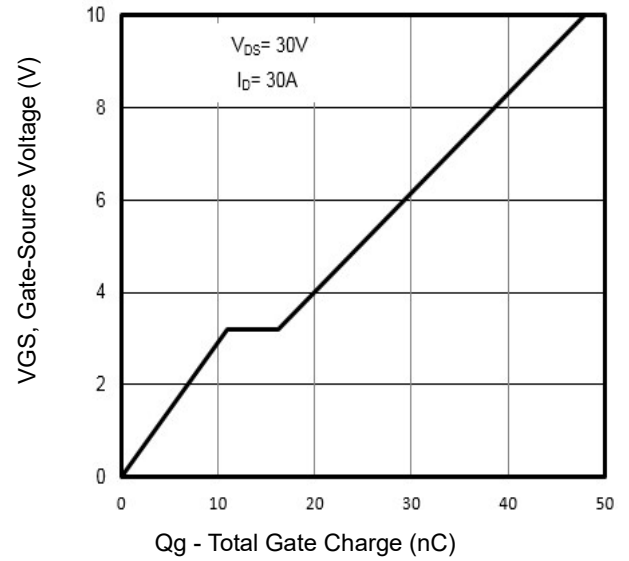
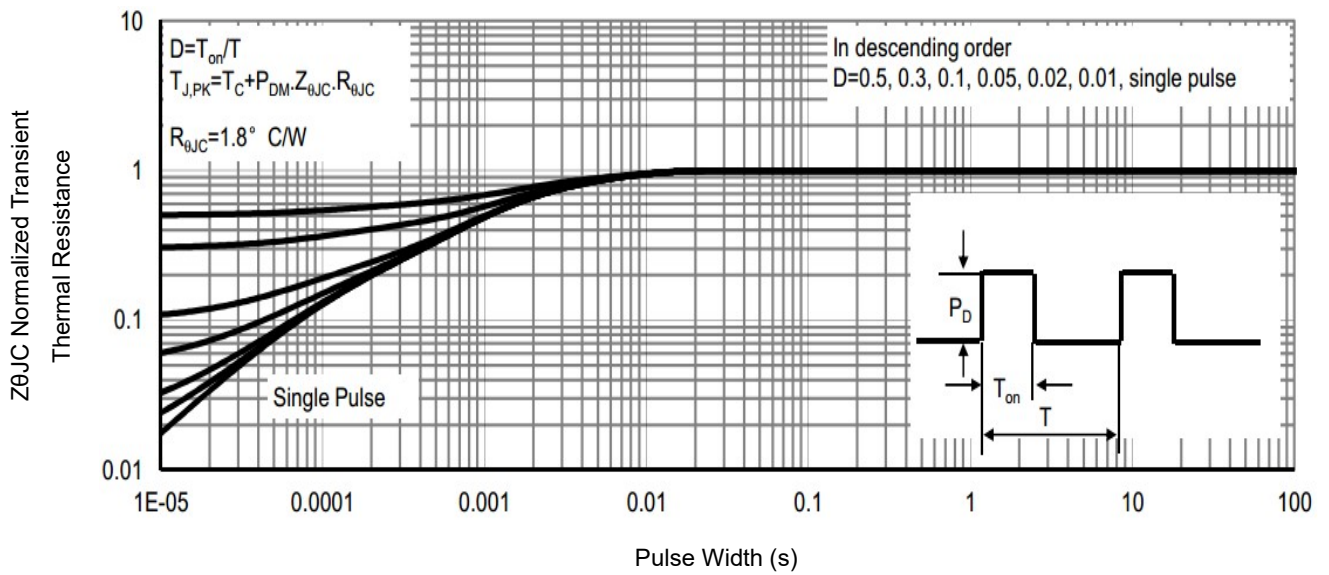
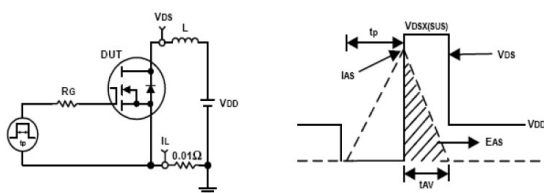
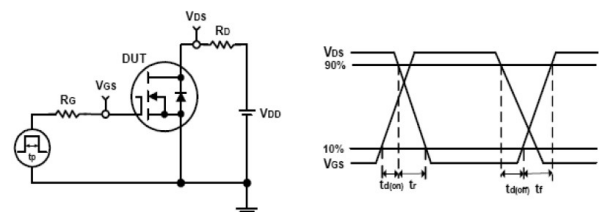
Fig1. Typical Output Characteristics

Fig2. $V_{GS(TH)}$ Gate-Source Voltage Vs. T_j

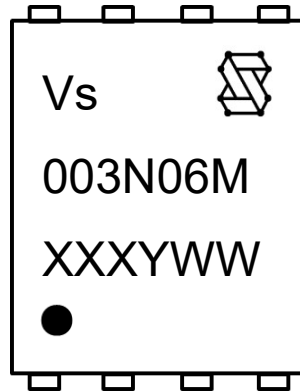
Fig3. Typical Transfer Characteristics

Fig4. Normalized On-Resistance Vs. T_j

Fig5. Typical Source-Drain Diode Forward Voltage

Fig6. Maximum Safe Operating Area

Typical Characteristics

Fig7. Typical Capacitance Vs. Drain-Source Voltage

Fig8. Typical Gate Charge Vs. Gate-Source Voltage

Fig9. Normalized Maximum Transient Thermal Impedance

Fig10. Unclamped Inductive Test Circuit and waveforms

Fig11. Switching Time Test Circuit and waveforms

Marking Information



1st line: Vergiga Code (Vs), Vergiga Logo

2nd line: Part Number (003N06M)

3rd line: Date code (XXXYWW)

XXX: Wafer Lot Number Code, code changed with Lot Number

Y: Year Code, refer to table below

WW: Week Code (01 to 53)

Code	C	D	E	F	G	H	J	K	L	M	N	P	Q	R	S	T
Year	2015	2016	2017	2018	2019	2020	2021	2022	2023	2024	2025	2026	2027	2028	2029	2030

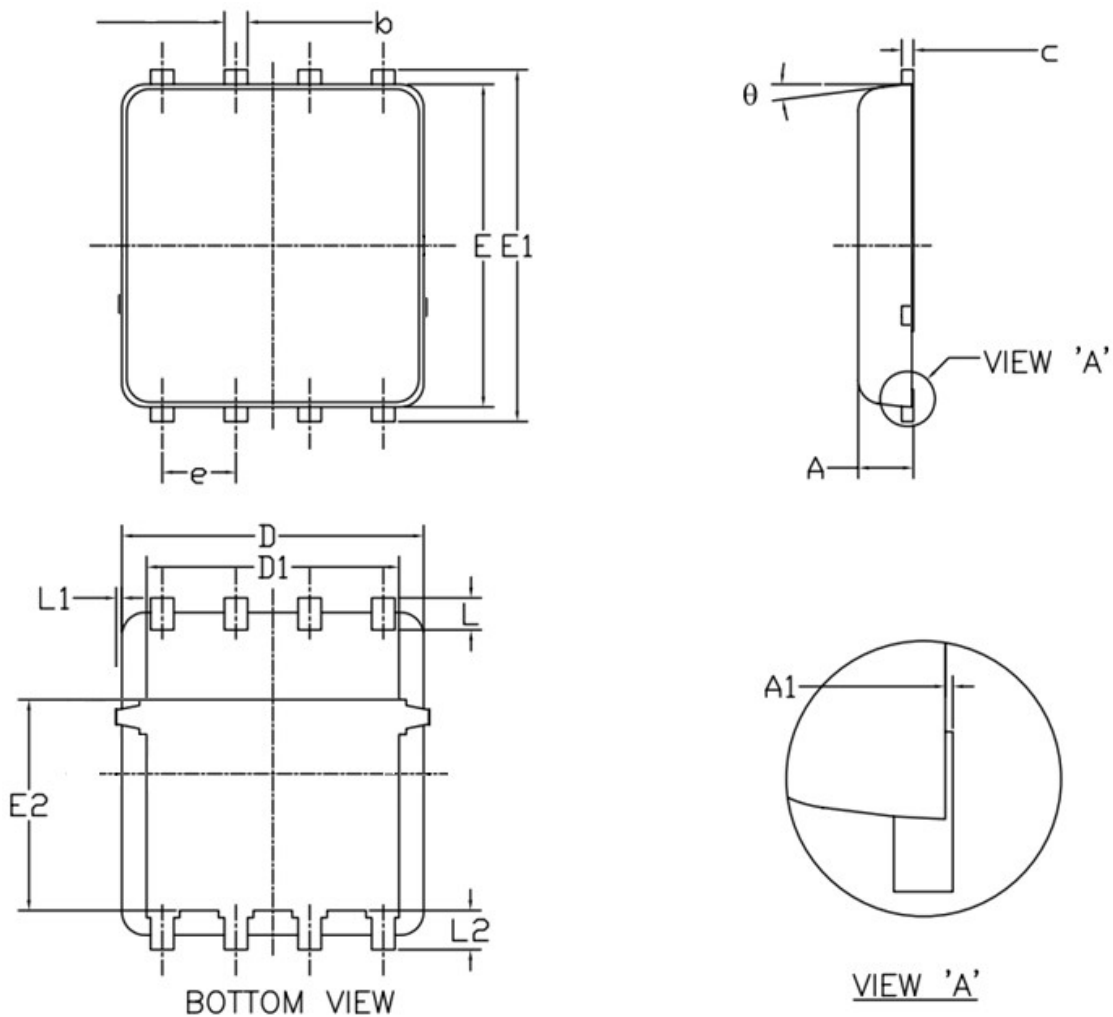
PDFN5x6 Package Outline Data

Symbol	DIMENSIONS (unit : mm)		
	Min	Typ	Max
A	0.90	1.00	1.20
A1	0.00	--	0.05
b	0.30	0.40	0.51
c	0.20	0.25	0.33
D	4.80	4.90	5.40
D1	3.61	4.00	4.25
E	5.65	5.80	6.06
E1	5.90	6.10	6.35
E2	3.38	3.58	3.92
e	1.27 BSC		
L	0.51	0.61	0.71
L1	--	--	0.15
L2	0.41	0.51	0.61
θ	0°	--	12°

Notes:

1. Refer to JEDEC MO-240 variation AA.
2. Dimensions "D" and "E" do NOT include mold flash protrusions or gate burrs.
3. Dimensions "D" and "E" include interterminal flash or protrusion. Interterminal flash or protrusion shall not exceed 0.25mm per side.

Customer Service
Sales and Service:
sales@vgsemi.com
Vergiga Semiconductor CO., LTD
TEL: (86-755)-26902410

FAX: (86-755)-26907027

WEB: www.vgsemi.com