

REV.	ECN NO.	DESCRIPTION	DATE	DESIGN
A				

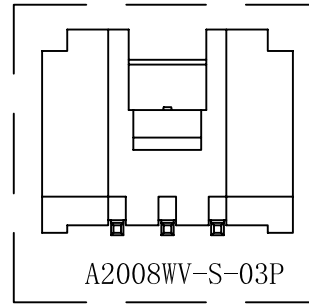

PART NO.	Dimensions(mm)	
	A	B
A2008WV-S-02P	8.00	2.00
A2008WV-S-03P	10.00	4.00
A2008WV-S-04P	12.00	6.00
A2008WV-S-05P	14.00	8.00
A2008WV-S-06P	16.00	10.00
A2008WV-S-07P	18.00	12.00
A2008WV-S-08P	20.00	14.00
A2008WV-S-09P	22.00	16.00
A2008WV-S-10P	24.00	18.00
A2008WV-S-11P	26.00	20.00
A2008WV-S-12P	28.00	22.00
A2008WV-S-13P	30.00	24.00
A2008WV-S-14P	32.00	26.00
A2008WV-S-15P	34.00	28.00
A2008WV-S-16P	36.00	30.00

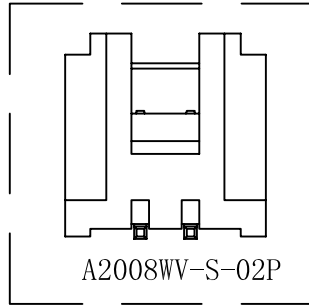
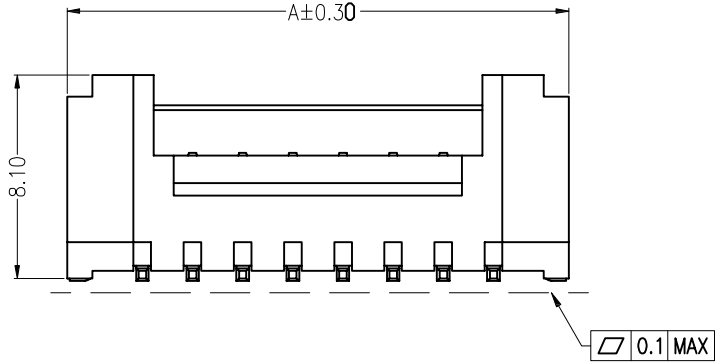
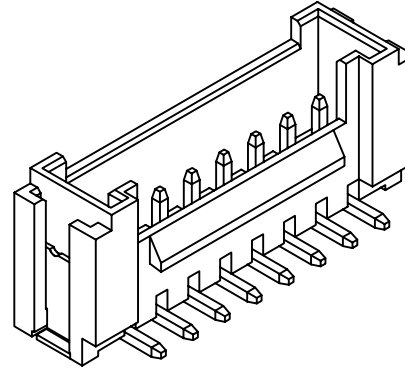
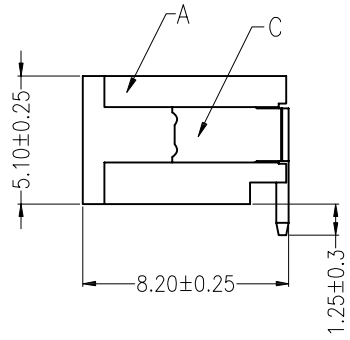
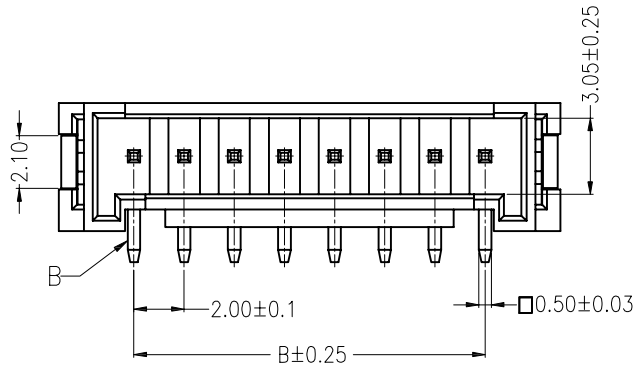
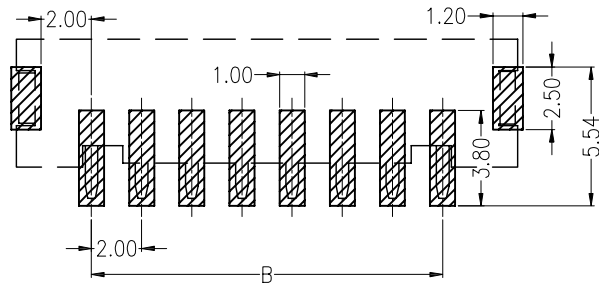

P. C. B LAYOUT

NOTES:

CURRENT RATING:3A AC/DC.  
 VOLTAGE RATING:250V AC/DC  
 TEMPERATURE RANGE:-40°C~+105°C.  
 CONTACT RESISTANCE:30MΩ Max.  
 INSULATION RESISTANCE:1000MΩ Min.  
 WITHSTANDING VOLTAGE: 1000V AC/MINUTE.  
 MATERIAL:LCP.UL94V-0.

**CNJM** Joint More Precision electronics Co.,Ltd.

DRAW NO.	DATE	P/N NO.	DRAW NAME:
DESIGN: 陈雪峰	2017.06.03	A2008WV-S-NP	2.0mm ptich wafer
CHECK: 杨焯			
REVIEW:		REV. A/1	SCALE 1:1
		UNIT: mm	SHEET: 1 OF 1

DIM	TOL	DIM	TOL
X.	/	X*	/
X.X	0.25	X.X*	
X.XX	0.15	X.XX*	
X.XXX	0.10	X.XXX*	/