

General Description

SY7219 is a high efficiency, current-mode control Boost DC to DC regulator with an integrated 65mΩ $R_{DS(ON)}$ N-channel MOSFET. The OFF time and the peak current limit can be programmed for more applications.

Ordering Information

SY7219
 Temperature Code
 Package Code
 Optional Spec Code

Ordering Number	Package type	Note
SY7219DBC	DFN3×3-10	----

Features

- Internal 9A switch
- Low $R_{DS(ON)}$ for internal switch: 65mΩ
- Programmable peak current limit
- Programmable constant OFF time
- Maximum voltage rating of internal switch 36V
- Internal softstart limiting the inrush current
- RoHS Compliant and Halogen Free
- Compact package: DFN3×3-10

Applications

- Industry control system
- Battery power system

Typical Applications

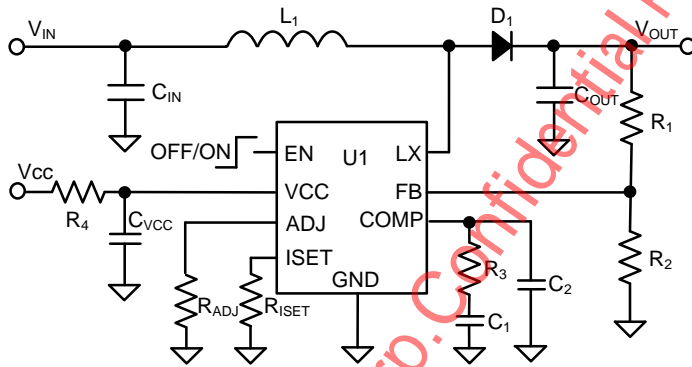

Figure 1. Schematic Diagram

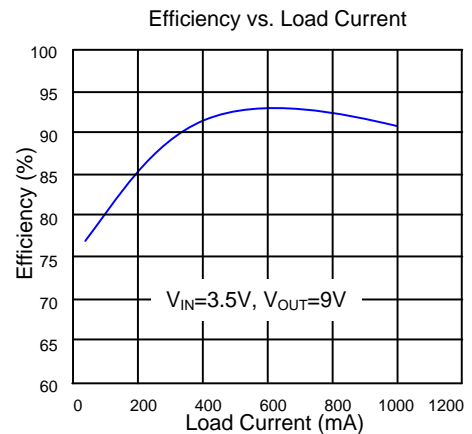
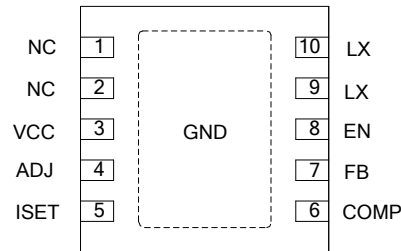

Figure 2. Efficiency vs. Load Current

Pinout (top view)



(DFN3×3-10)

Top Mark: GVxyz (Device code:GV, x=year code, y=week code, z= lot number code)

Pin Name	Pin Number	Pin Description
VCC	3	Power supply pin.
ADJ	4	Connect a resistor to ground to program the turn off time.
ISET	5	Connect a resistor to ground to program the current limit point of the internal MOSFET.
COMP	6	Compensation pin. Connect RC network between this pin and ground to program the best transient response.
FB	7	Output Feedback Pin. The reference voltage is 1.25V. If the voltage on FB pin is higher than the reference voltage by 5%, the OVP is triggered.
EN	8	Enable control pin. Connect this pin to VCC by a 1kΩ resistor recommended.
LX	9,10	Switching node. Connect this pin to switching node of the inductor.
GND	Exposed pad	Ground pin

Block Diagram

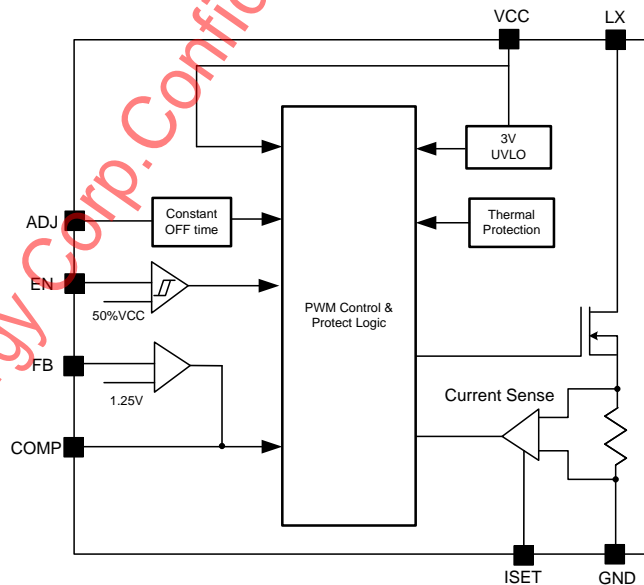

Absolute Maximum Ratings (Note 1)

LX	-----	36V
All other pins	-----	5.5V
Power Dissipation, Pd @ TA = 25 °C DFN3X3-10	-----	2.6W
Package Thermal Resistance (Note 2)		
θ_{JA}	-----	38 °C/W
θ_{JC}	-----	8 °C/W
Junction Temperature Range	-----	125 °C
Lead Temperature (Soldering, 10 sec.)	-----	260 °C
Storage Temperature Range	-----	-65 °C to 150 °C
Dynamic LX voltage in 50ns duration	-----	39V to GND-4V

Recommended Operating Conditions (Note 3)

LX	-----	-30V
EN, VCC	-----	5.5V
All other pins	-----	3V
Junction Temperature Range	-----	-40 °C to 125 °C
Ambient Temperature Range	-----	-40 °C to 85 °C

Electrical Characteristics

(VCC = 5.0V, TA = 25 °C, unless otherwise specified)

Parameter	Symbol	Conditions	Min	Typ	Max	Unit
VCC Input Voltage Range	V _{CC}		3		5.5	V
VCC Rising UVLO Threshold	V _{UVLO,UP}				3	V
VCC UVLO Hysteresis	V _{UVLO,HYS}			0.4		V
Quiescent Current	I _Q	V _{FB} =1.3V		380		μA
Shut Down Current	I _S	V _{CC} =5V, V _{EN} =0V		1		μA
NFET R _{DS(ON)}	R _{DS(ON)}			65		mΩ
Maximum Peak Current limited	I _{SM}	R _{ISSET} =75kΩ	8	9		A
OFF Time	T _{OFF}	R _{ADJ} =200kΩ	1.75	2.0	3.25	μs
EN Rising Threshold	V _{ENH}		2.7			V
EN Falling Threshold	V _{ENL}				0.8	V
Minimum ON Time	T _{ON,MIN}			100		ns
Feedback Voltage	V _{FB}		1.225	1.25	1.275	V
FB Input Current	I _{FB}	V _{FB} =3V	-50		50	nA
Thermal Shutdown Temperature	T _{SD}			150		°C
Thermal Shutdown Recovery Hysteresis	T _{HYS}			15		°C

Note 1: Stresses listed beyond “Absolute Maximum Ratings” may cause permanent damage to the device. These are for stress ratings. Functional operation of the device at these or any other conditions beyond those indicated in the operational sections of the specifications is not implied. Exposure to absolute maximum rating conditions may affect device reliability.

Note 2: θ_{JA} is measured in the natural convection at TA = 25 °C on a low effective single layer thermal conductivity test board of JEDEC 51-3 thermal measurement standard.

Note 3: The device is not guaranteed to function outside its operating conditions.

Typical Performance Characteristics

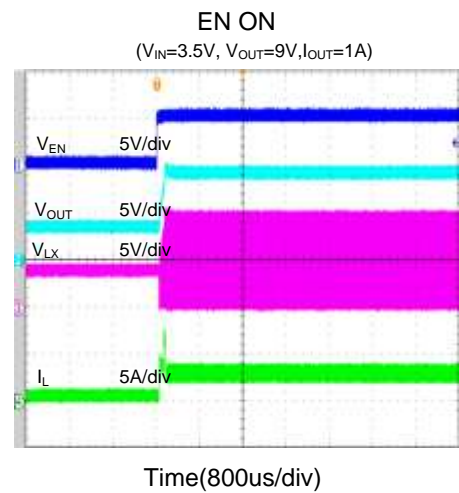
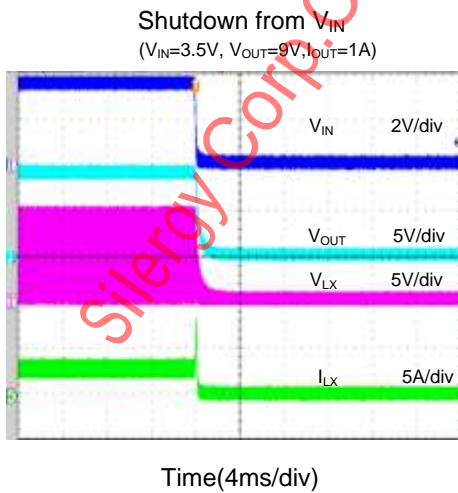
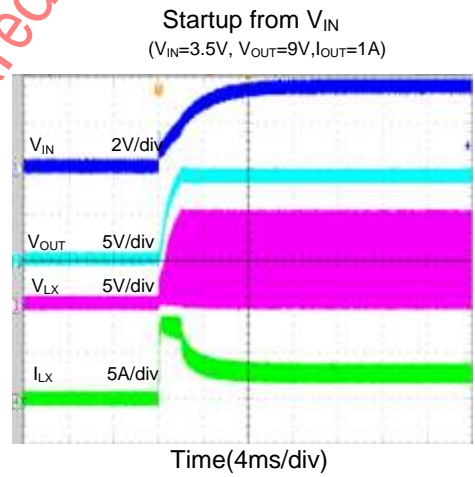
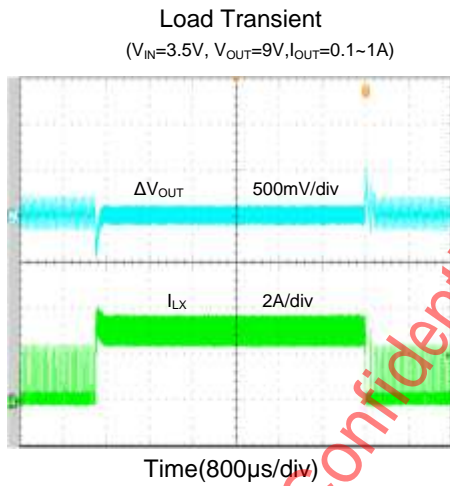
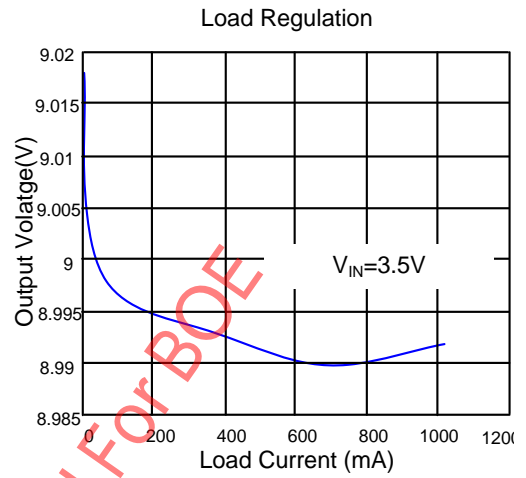
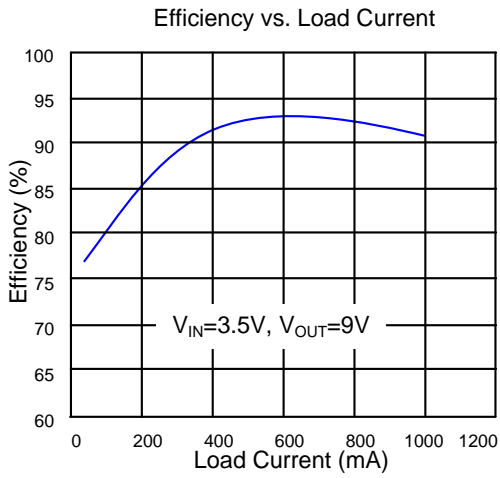

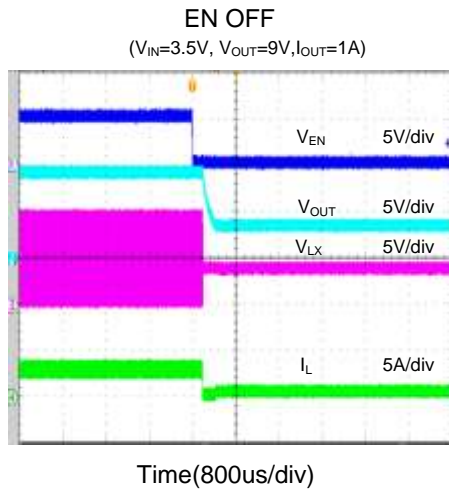

Silergy Corp. Confidential Prepared For BOE

Applications Information

Feedback resistor dividers R₁ and R₂:

Choose R₁ and R₂ to program the proper output voltage. To minimize the power consumption under light loads, it is desirable to choose large resistance values for both R₁ and R₂. A value of between 10k and 1M is recommended for both resistors. If R₁=200k is chosen, then R₂ can be calculated to be:

$$R_2 = (R_1 \times 1.25V) / (V_{OUT} - 1.25V)$$

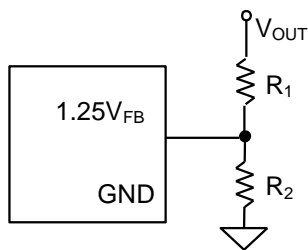

Current limit Setting resistor R_{ISET}:

Current limit can be programmed by adjusting external resistor R_{ISET} connected to ISET:

$$R_{ISET} = \frac{680A}{I_{SM}} \times k\Omega$$

Programmable constant off time

OFF time can be programmed by adjusting external resistor R_{ADJ} connected to ADJ pin:

$$R_{ADJ} = \frac{T_{OFF}}{10ns} \times k\Omega$$

Input capacitor C_{IN}:

The ripple current through input capacitor is calculated as:

$$I_{CIN_RMS} = \frac{(V_{OUT} - V_{IN}) \times T_{OFF}}{2\sqrt{3} \times L}$$

To minimize the potential noise problem, place a typical X5R or better grade ceramic capacitor really close to the L₁ and GND pins. Care should be taken to minimize the loop area formed by C_{IN}, L₁ and GND pins. In this case a 10uF low ESR ceramic is recommended.

VCC capacitor C_{VCC}:

The VCC capacitor must be close to the VCC and GND pins to minimize the potential noise problem.

Care should be taken to minimize the loop area formed by C_{VCC}, and VCC/GND pins. In this case a 2uF low ESR ceramic is recommended.

Output capacitor C_{OUT}:

The output capacitor is selected to handle the output ripple noise requirements. Both steady state ripple and transient requirements must be taken into consideration when selecting this capacitor. For the best performance, it is recommended to use X5R or better grade ceramic capacitor with 35V rating and more than two pcs 10uF capacitor.

Boost inductor L:

There are several considerations in choosing this inductor.

- 1) Choose the inductance to provide the desired ripple current. It is suggested to choose the ripple current to be about 40% of the maximum average input current. The inductance is calculated as:

$$L = \frac{V_{IN}}{V_{OUT}} \times \frac{(V_{OUT} - V_{IN}) \times T_{OFF}}{I_{OUT_MAX} \times 40\%}$$

where T_{OFF} is set by R_{ADJ} and I_{OUT,MAX} is the maximum load current.

The SY7219 regulator IC is quite tolerant of different ripple current amplitude. Consequently, the final choice of inductance can be slightly off the calculation value without significantly impacting the performance.

- 2) The saturation current rating of the inductor must be selected to be greater than the peak inductor current under full load conditions.

$$I_{SAT_MIN} > \left(\frac{V_{OUT}}{V_{IN}}\right) \times I_{OUT_MAX} + \frac{V_{IN} \times (V_{OUT} - V_{IN})}{2 \times F_{SW} \times L \times V_{OUT}}$$

- 3) The DCR of the inductor and the core loss at the switching frequency must be low enough to achieve the desired efficiency requirement. It is desirable to choose an inductor with DCR < 50mohm to achieve a good overall efficiency.



Enable Operation

Pulling the EN pin low will shut down the device. During the shut down mode, the SY7219 shut down current drops to lower than $1\mu\text{A}$. Driving the EN pin high will turn on the IC again.

Diode Selection

Schottky diode is a good choice for high efficiency operation because of its low forward voltage drop and fast reverse recovery. The maximum current rating of the diode must be higher than maximum input current. And the average current rating of the diode must be higher than the output current.

Layout Design:

The layout design of SY7219 regulator is relatively simple. For the best efficiency and minimum noise problems, we should place the following components close to the IC: C_{IN} , C_{VCC} , L_1 , R_1 and R_2 .

1) It is desirable to maximize the PCB copper area connecting to GND pin to achieve the best thermal and noise performance. If the board space allowed, a ground plane is highly desirable.

2) C_{OUT} must be close to D_1 , Pin LX and Pin GND. The loop area formed by C_{OUT} and GND must be minimized.

3) The PCB copper area associated with LX pin must be minimized to avoid the potential noise problem.

4) The components R_1 and R_2 , and the trace connected to the FB pin must NOT be adjacent to the LX net on the PCB layout to avoid the noise problem.

5) The VCC capacitor must be close to the VCC and GND pins

Silergy Corp. Confidential Prepared For People

DFN3x3-10 Package outline

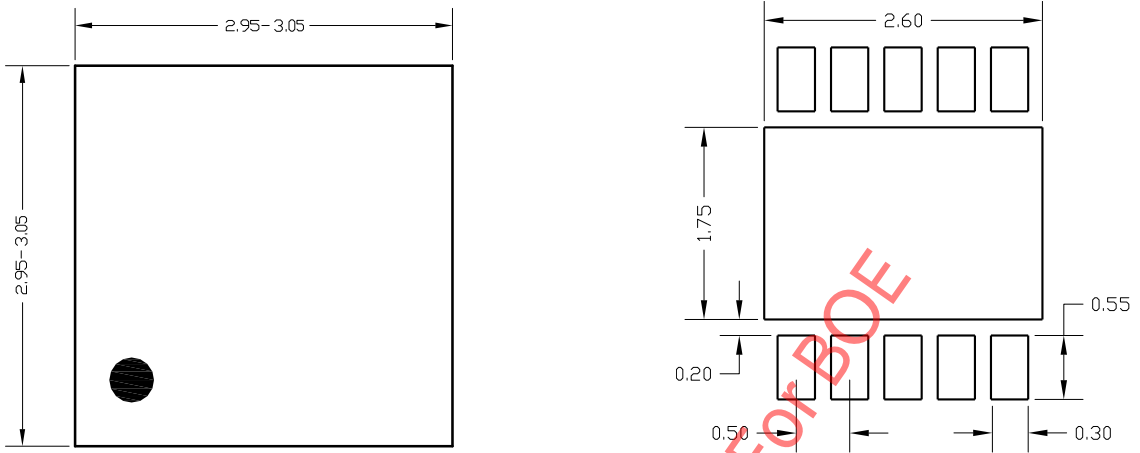

Top View

PCB layout (recommended)

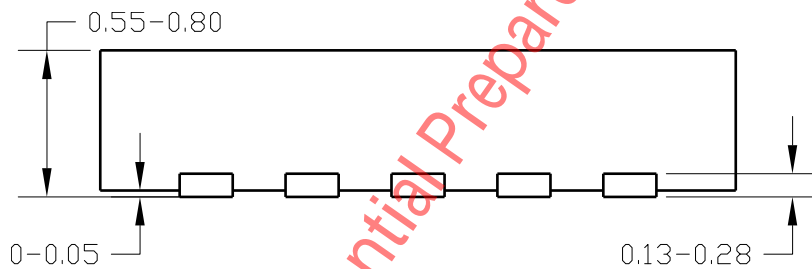

Side View

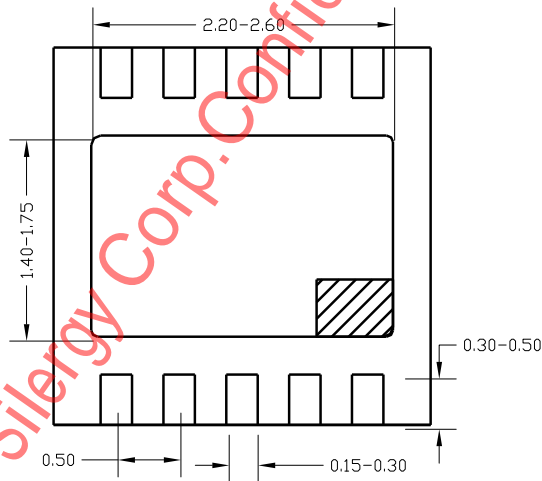

Bottom View

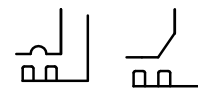

Detail A
Pin1 identifier: two options

Notes: All dimensions are in millimeters and exclude mold flash & metal burr.

Taping & Reel Specification

1. DFN3x3 taping orientation

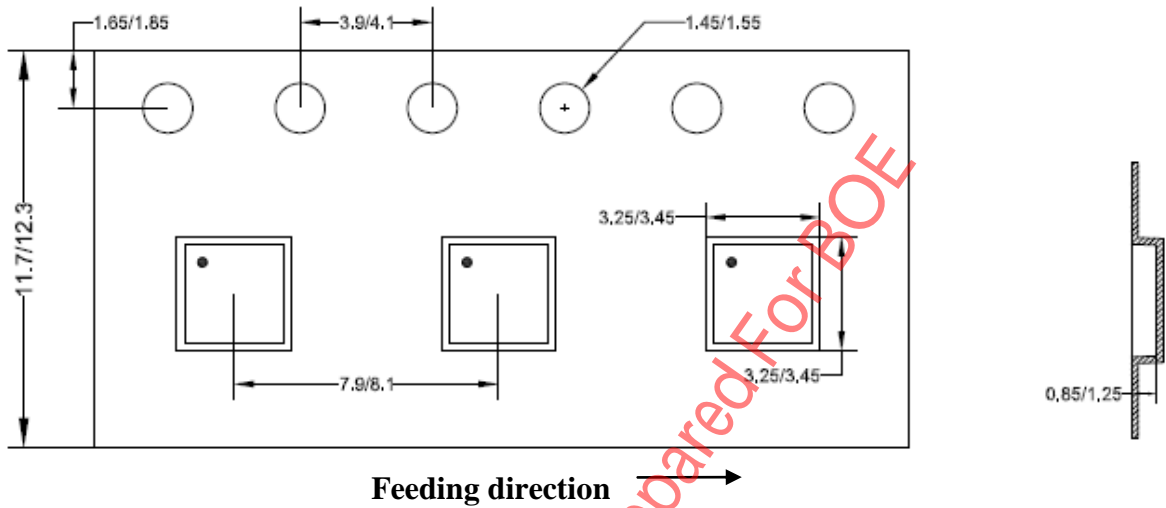

2. Carrier Tape & Reel specification for packages

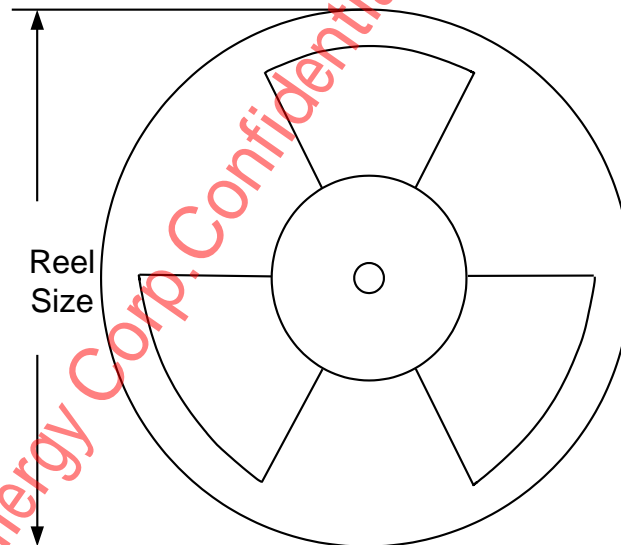

Package types	Tape width (mm)	Pocket pitch (mm)	Reel size (Inch)	Trailer length (mm)	Leader length (mm)	Qty per reel
DFN3x3	12	8	13"	400	400	5000

3. Others: NA



IMPORTANT NOTICE

- 1. Right to make changes.** Silergy and its subsidiaries (hereafter Silergy) reserve the right to change any information published in this document, including but not limited to circuitry, specification and/or product design, manufacturing or descriptions, at any time and without notice. This document supersedes and replaces all information supplied prior to the publication hereof. Buyers should obtain the latest relevant information before placing orders and should verify that such information is current and complete. All semiconductor products are sold subject to Silergy's standard terms and conditions of sale.
- 2. Applications.** Application examples that are described herein for any of these products are for illustrative purposes only. Silergy makes no representation or warranty that such applications will be suitable for the specified use without further testing or modification. Buyers are responsible for the design and operation of their applications and products using Silergy products. Silergy or its subsidiaries assume no liability for any application assistance or designs of customer products. It is customer's sole responsibility to determine whether the Silergy product is suitable and fit for the customer's applications and products planned. To minimize the risks associated with customer's products and applications, customer should provide adequate design and operating safeguards. Customer represents and agrees that it has all the necessary expertise to create and implement safeguards which anticipate dangerous consequences of failures, monitor failures and their consequences, lessen the likelihood of failures that might cause harm and take appropriate remedial actions. Silergy assumes no liability related to any default, damage, costs or problem in the customer's applications or products, or the application or use by customer's third-party buyers. Customer will fully indemnify Silergy, its subsidiaries, and their representatives against any damages arising out of the use of any Silergy components in safety-critical applications. It is also buyers' sole responsibility to warrant and guarantee that any intellectual property rights of a third party are not infringed upon when integrating Silergy products into any application. Silergy assumes no responsibility for any said applications or for any use of any circuitry other than circuitry entirely embodied in a Silergy product.
- 3. Limited warranty and liability.** Information furnished by Silergy in this document is believed to be accurate and reliable. However, Silergy makes no representation or warranty, expressed or implied, as to the accuracy or completeness of such information and shall have no liability for the consequences of use of such information. In no event shall Silergy be liable for any indirect, incidental, punitive, special or consequential damages, including but not limited to lost profits, lost savings, business interruption, costs related to the removal or replacement of any products or rework charges, whether or not such damages are based on tort or negligence, warranty, breach of contract or any other legal theory. Notwithstanding any damages that customer might incur for any reason whatsoever, Silergy' aggregate and cumulative liability towards customer for the products described herein shall be limited in accordance with the Standard Terms and Conditions of Sale of Silergy.
- 4. Suitability for use.** Customer acknowledges and agrees that it is solely responsible for compliance with all legal, regulatory and safety-related requirements concerning its products, and any use of Silergy components in its applications, notwithstanding any applications-related information or support that may be provided by Silergy. Silergy products are not designed, authorized or warranted to be suitable for use in life support, life-critical or safety-critical systems or equipment, nor in applications where failure or malfunction of an Silergy product can reasonably be expected to result in personal injury, death or severe property or environmental damage. Silergy assumes no liability for inclusion and/or use of Silergy products in such equipment or applications and therefore such inclusion and/or use is at the customer's own risk.
- 5. Terms and conditions of commercial sale.** Silergy products are sold subject to the standard terms and conditions of commercial sale, as published at <http://www.silergy.com/stdterms>, unless otherwise agreed in a valid written individual agreement specifically agreed to in writing by an authorized officer of Silergy. In case an individual agreement is concluded only the terms and conditions of the respective agreement shall apply. Silergy hereby expressly objects to and denies the application of any customer's general terms and conditions with regard to the purchase of Silergy products by the customer.
- 6. No offer to sell or license.** Nothing in this document may be interpreted or construed as an offer to sell products that is open for acceptance or the grant, conveyance or implication of any license under any copyrights, patents or other industrial or intellectual property rights. Silergy makes no representation or warranty that any license, either express or implied, is granted under any patent right, copyright, mask work right, or other intellectual property right. Information published by Silergy regarding third-party products or services does not constitute a license to use such products or services or a warranty or endorsement thereof. Use of such information may require a license from a third party under the patents or other intellectual property of the third party, or a license from Silergy under the patents or other intellectual property of Silergy.

For more information, please visit: www.silergy.com

© 2018 Silergy Corp.

All Rights Reserved.