

GENERAL DESCRIPTION

OB2226N is a high performance, high precision and low cost PWM Power switch for non-isolated buck application. It combines a dedicated current mode PWM controller (with a high voltage power MOSFET with DIP7 package) and built-in error amplifier for low cost and component count. With precise inner resistor divider, precise reference of EA and load compensation, accurate constant voltage regulation at universal AC input can be guaranteed. For high efficiency, oscillator with frequency-reduction control is implemented. And EMI performance is achieved with On-Bright proprietary frequency shuffling technique.

OB2226N offers power on soft start control and protection coverage with auto-recovery features including Cycle-by-Cycle current limiting, over loading protection, output short-circuit protection, over temperature protection, VDD OVP, and UVLO.

OB2226N is offered in DIP7 package.

FEATURES

- Low cost and component count buck application
- Built-in error amplifier
- Load compensation
- Oscillator of fixed frequency with frequency-reduction control for high efficiency
- Frequency shuffling for EMI improvement
- Power on Soft-start
- Built-in Leading Edge Blanking (LEB)
- Cycle-by-Cycle Current Limiting
- Over Loading Protection
- Output Short-Circuit Protection
- Over Temperature Protection
- VDD Under Voltage Lockout with Hysteresis (UVLO)
- VDD OVP

APPLICATIONS

Low Power AC/DC offline SMPS for

- Electrical Appliance
- Linear Regulator/RCC Replacement

TYPICAL APPLICATION

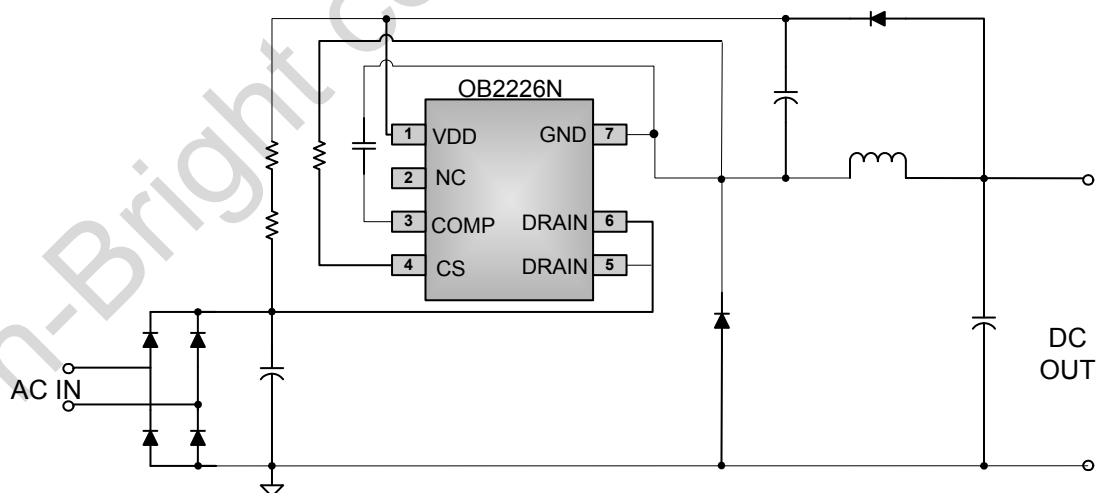

GENERAL INFORMATION

Pin Configuration

The pin map is shown as below for DIP7.

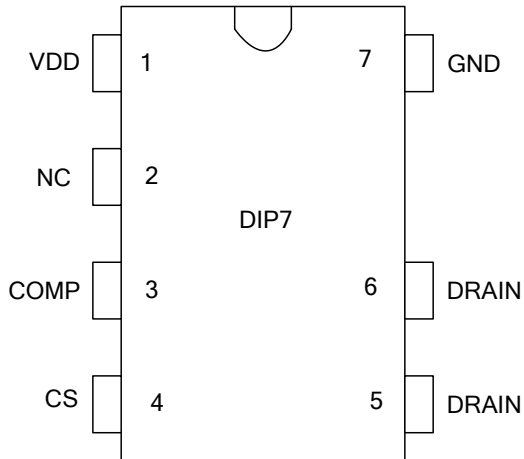

Package Dissipation Rating

| Package | R θ JA (°C/W) |
|---------|----------------------|
| DIP7 | 75 |

Note: Drain Pin Connected 100mm² PCB copper clad.

Absolute Maximum Ratings

| Parameter | Value |
|---|----------------|
| Drain Voltage (off state) | -0.3V to BVdss |
| VDD Voltage | -0.3 to 40V |
| VDD Zener Clamp Continuous Current | 10 mA |
| COMP Voltage | -0.3 to 7V |
| CS Input Voltage | -0.3 to 7V |
| Min/Max Operating Junction Temperature T _J | -40 to 150 °C |
| Min/Max Storage Temperature T _{stg} | -55 to 150 °C |
| Lead Temperature (Soldering, 10secs) | 260 °C |

Ordering Information

| Part Number | Description |
|-------------|---------------------|
| OB2226NSP-H | DIP7, Pb-free, Tube |

Note: Stresses beyond those listed under "absolute maximum ratings" may cause permanent damage to the device. These are stress ratings only, functional operation of the device at these or any other conditions beyond those indicated under "recommended operating conditions" is not implied. Exposure to absolute maximum-rated conditions for extended periods may affect device reliability.

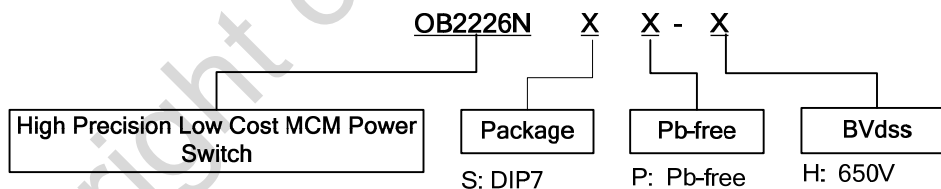

Marking Information

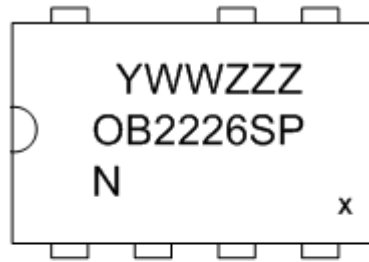

Y:Year Code
 WW:Week Code(01-52)
 ZZZ:Lot Code
 S:DIP7 Package
 P:Pb-free Package
 N:Character Code
 X:Internal Code(Optional)

TERMINAL ASSIGNMENTS

| Pin Num | Pin Name | I/O | Description |
|---------|----------|-----|--|
| 1 | VDD | P | Power Supply |
| 2 | NC | I | Not connected |
| 3 | COMP | I | Loop Compensation for CV Stability |
| 4 | CS | I | Current sense input |
| 5/6 | DRAIN | O | HV MOSFET Drain Pin. The Drain pin is connected to the primary lead of the transformer / inductance. |
| 7 | GND | P | Ground |

OUTPUT POWER TABLE

| Product | 90~300VAC | 90~264VAC |
|-----------|---------------------------|------------------------------|
| | Buck topology, open frame | Flyback topology, open frame |
| OB2226NSP | 6.6W | 10W |

BLOCK DIAGRAM

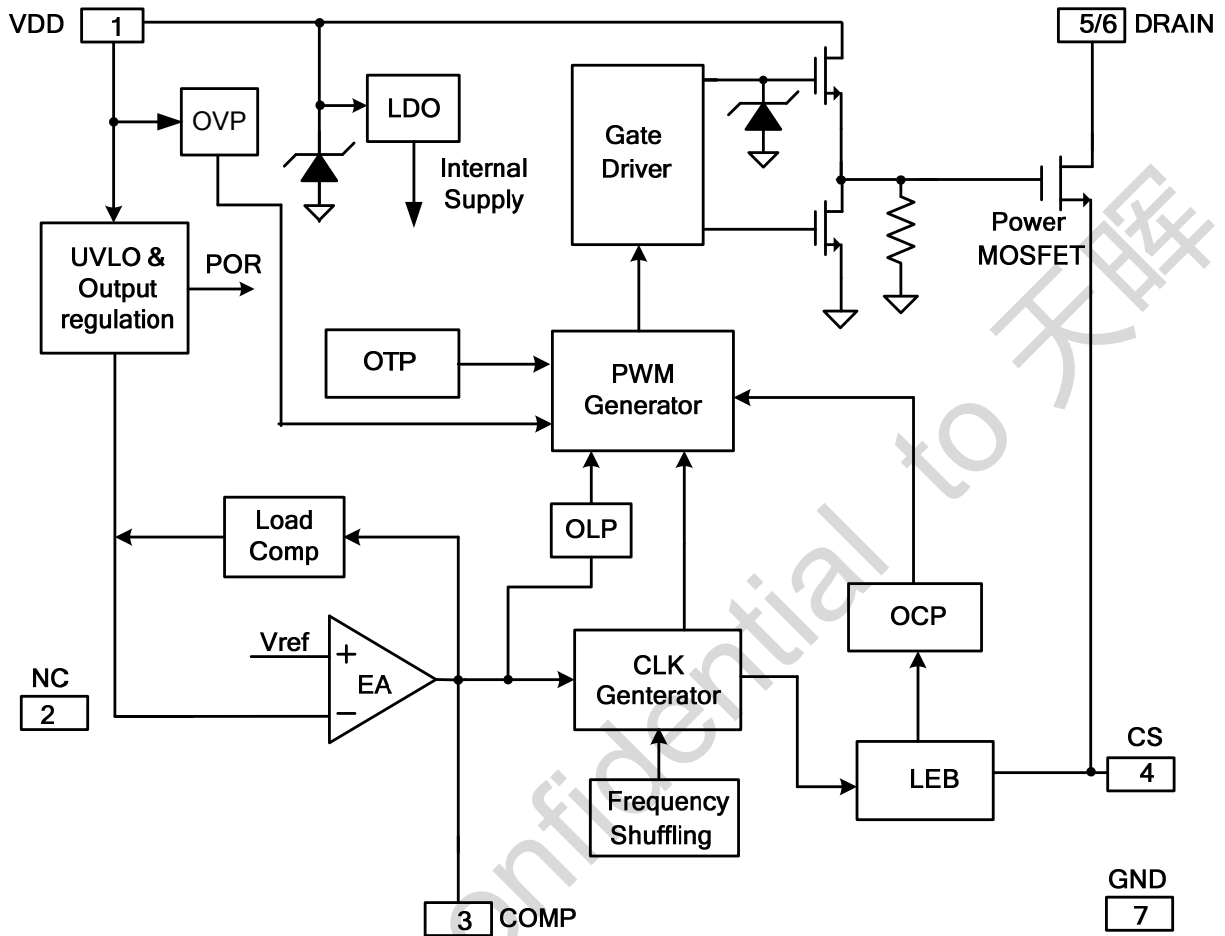

ELECTRICAL CHARACTERISTICS

 (T_A = 25°C, VDD=16V, if not otherwise noted)

| Symbol | Parameter | Test Conditions | Min | Typ | Max | Unit |
|-------------------------------------|---|--|------|------|------|------|
| Supply Voltage (VDD) Section | | | | | | |
| I _{DD ST} | Standby Current | VDD=13V | | 5 | 20 | uA |
| I _{DD op} | Operation Current | Operation supply current CS=0V, VDD=18V | - | 1.5 | 2.5 | mA |
| UVLO(ON) | VDD Under Voltage Lockout Enter | VDD falling | 8.2 | 9.0 | 10.5 | V |
| UVLO(OFF) | VDD Under Voltage Lockout Exit | VDD rising | 13.5 | 14.8 | 16.0 | V |
| OVP | Over voltage protection Threshold | Ramp VDD until gate shut down | 26 | 27.5 | 29 | V |
| VDD Regulation Voltage | In normal regulation, VDD will be regulated to 19.3V | Ramp VDD until Comp voltage lower than 2.5V | 18.6 | 19.3 | 20.0 | V |
| Current Sense Input Section | | | | | | |
| TLEB | LEB time | | | 200 | | ns |
| Vth_oc | Over current threshold | | 910 | 940 | 970 | mV |
| Td_oc | OCP propagation delay | | | 110 | | ns |
| Z _{SENSE_IN} | Input Impedance | | 50 | | | kΩ |
| Frequency Section | | | | | | |
| Freq_Max | IC Maximum frequency | | 40 | 45 | 50 | kHz |
| Δf/Freq | Frequency shuffling range | | | +/-6 | | % |
| Error Amplifier Section | | | | | | |
| Gain | DC gain of EA | | | 60 | | dB |
| I _{COMP_MAX} | Max. Cable compensation current | VDD=18V, Comp=0V | | 3.3 | | uA |
| Protection | | | | | | |
| V _{TH_OLP} | Over loading protection threshold voltage | | | 4 | | V |
| T _{d_OLP} | Over load, debounce Time | | | 100 | | ms |
| OTP enter | | | | 150 | | °C |
| OTP exit | | | | 130 | | °C |
| Power MOSFET Section | | | | | | |
| BVdss | MOSFET Drain-Source Breakdown Voltage | | 650 | | | V |
| Rdson | On Resistance | | | | 15 | Ω |

CHARACTERIZATION PLOTS

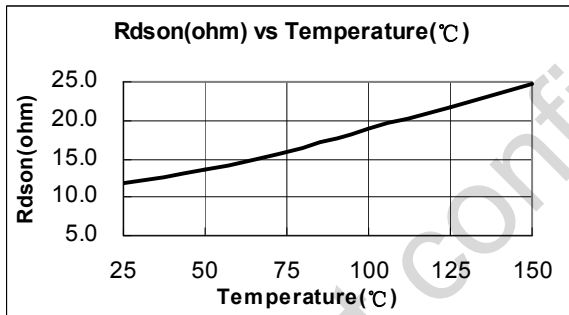
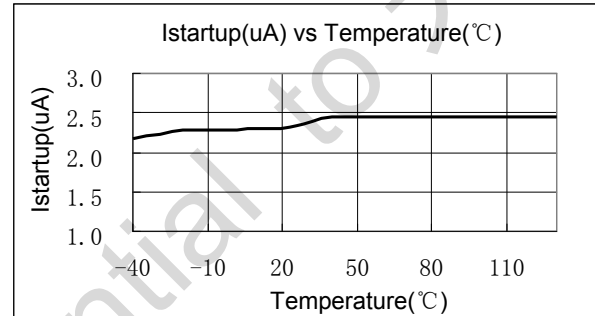
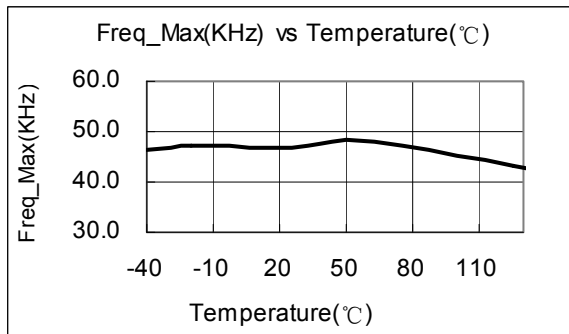
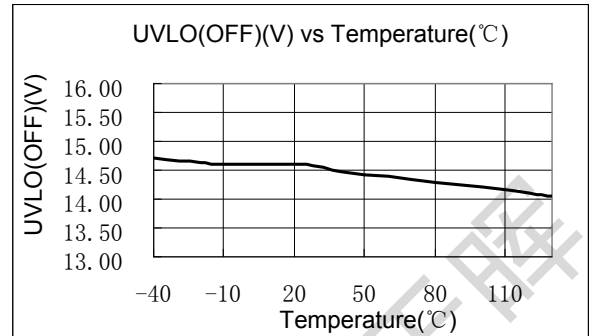
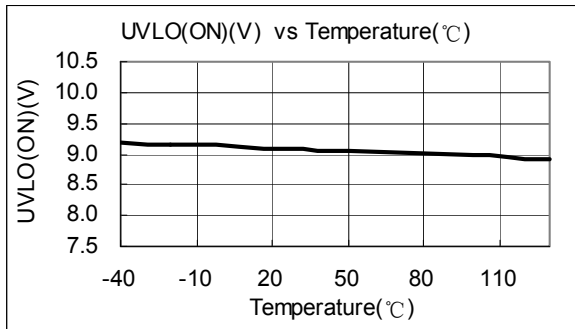

OPERATION DESCRIPTION

OB2226N is a cost effective PWM power switch optimized for off-line non-isolated buck applications including electrical appliance and linear regulator replacement. It operates in current mode and regulates output voltage with dedicated features. High integration can afford low cost and component count solution.

- **Startup Current and Start up Control**

Startup current of OB2226N is designed to be very low so that VDD could be charged up above UVLO threshold and starts up quickly. A large value startup resistor can therefore be used to minimize the power loss in application.

- **Operating Current**

The Operating current of OB2226N is as low as 1.5mA (typical). Good efficiency is achieved with the low operating current together with 'Multi-mode' control features.

- **Oscillator operation**

The switching frequency of OB2226N is internally fixed at 45KHz (typical). No external frequency setting components are required for PCB design simplification.

At light load or zero load condition, most of the power dissipation in a switching mode power supply is from switching loss on the MOSFET. The magnitude of power loss is in proportion to the switching frequency. Lower switching frequency leads to the reduction on the power loss and thus conserves the energy. The switching frequency is internally adjusted at light load or no load condition. The switch frequency reduces at light/no load condition to improve the conversion efficiency. The minimum switching frequency is 400Hz (typical).

- **Frequency shuffling for EMI improvement**

The frequency shuffling (switching frequency modulation) is implemented in OB2226N. The oscillation frequency is modulated so that the tone energy is spread out. The spread spectrum minimizes the conduction band EMI and therefore eases the system design.

- **Built-in error amplifier**

In OB2226N, on-chip EA (error amplifier) is implemented to regulate output voltage. Through inner resistor divider, the VDD voltage is detected at inverter input of EA to regulate output voltage.

- **Load Compensation for good CV regulation**

In OB2226N, load compensation is implemented to achieve good load regulation. An offset voltage is generated at inverter input of EA by an internal current flowing into the resistor divider. The current is inversely proportional to the voltage across pin COMP, as a result, it is inversely proportional to the output load current, therefore the output voltage can be compensated specially in zero loading condition. As the load current decreases from full-load to no-load, the offset voltage at inverter input of EA will increase.

- **Current Sensing and Leading Edge Blanking**

Cycle-by-Cycle current limiting is offered in OB2226N current mode PWM control. The switch current is detected by a sense resistor into the CS pin. An internal leading edge blanking circuit chops off the sensed voltage spike at initial internal power MOSFET on state so that the external RC filtering on sense input is no longer needed. The PWM duty cycle is determined by the current sense input voltage and the EA output voltage.

- **Gate Driver**

The internal power MOSFET in OB2226N is driven by a dedicated gate driver for power switch control. Too weak the gate driver strength results in higher conduction and switch loss of MOSFET while too strong gate drive compromises EMI. A good tradeoff is achieved through the built-in totem pole gate design with right output strength control.

- **Protection Control**

Good power supply system reliability is achieved with its rich protection features including Cycle-by-Cycle current limiting (OCP), Over Loading Protection, Over Voltage Protection, Output Short-Circuit Protection and Under Voltage Lockout on VDD (UVLO). To prevent from any lethal thermal damage, OB2226N stops switching when the junction temperature exceeds 150°C (typical). When the junction temperature drops below 130°C (typical), OB2226N resumes operation.

PACKAGE MECHANICAL DATA

DIP7 PACKAGE OUTLINE DIMENSIONS

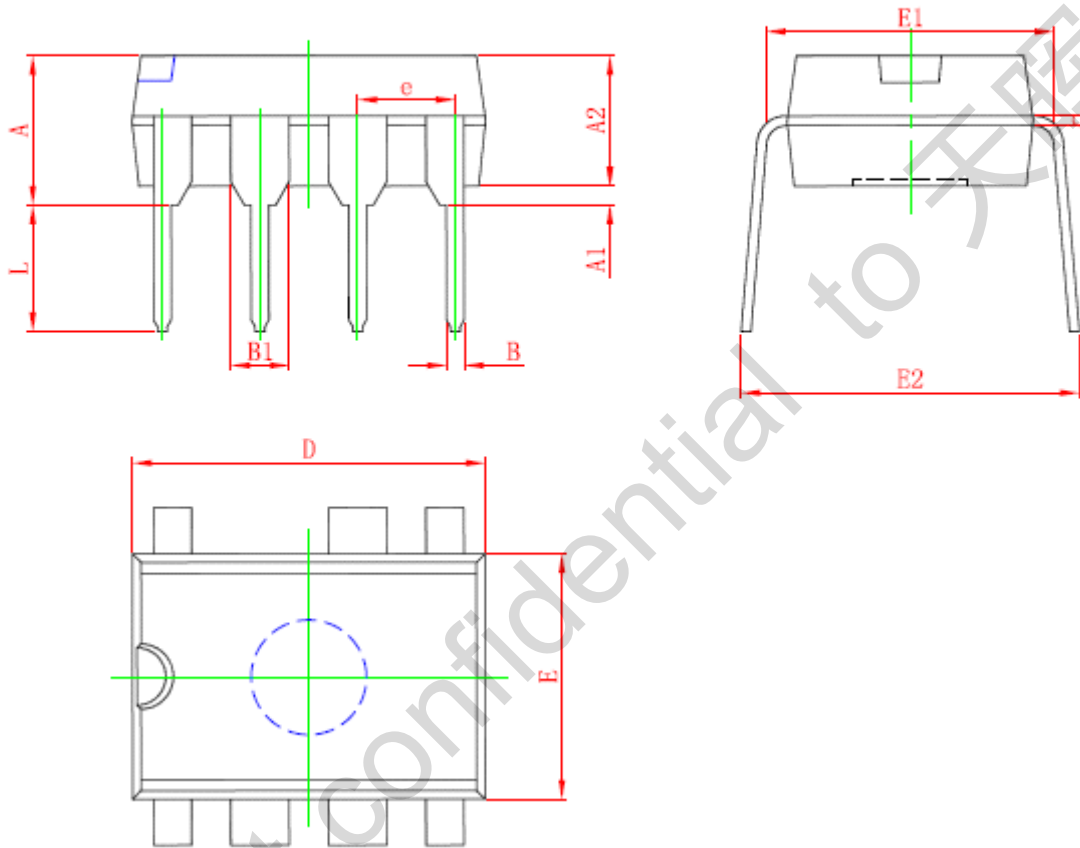

| Symbol | Dimensions In Millimeters | | Dimensions In Inches | |
|--------|---------------------------|--------|----------------------|-------|
| | Min | Max | Min | Max |
| A | 3.710 | 5.334 | 0.146 | 0.210 |
| A1 | 0.381 | | 0.015 | |
| A2 | 2.921 | 4.953 | 0.115 | 0.195 |
| B | 0.350 | 0.650 | 0.014 | 0.026 |
| B1 | 1.524 (BSC) | | 0.06 (BSC) | |
| C | 0.200 | 0.360 | 0.008 | 0.014 |
| D | 9.000 | 10.160 | 0.354 | 0.400 |
| E | 6.096 | 7.112 | 0.240 | 0.280 |
| E1 | 7.320 | 8.255 | 0.288 | 0.325 |
| e | 2.540 (BSC) | | 0.1 (BSC) | |
| L | 2.921 | 3.810 | 0.115 | 0.150 |
| E2 | 7.620 | 10.920 | 0.300 | 0.430 |

IMPORTANT NOTICE

RIGHT TO MAKE CHANGES

On-Bright Electronics Corp. reserves the right to make corrections, modifications, enhancements, improvements and other changes to its products and services at any time and to discontinue any product or service without notice. Customers should obtain the latest relevant information before placing orders and should verify that such information is current and complete.

WARRANTY INFORMATION

On-Bright Electronics Corp. warrants performance of its hardware products to the specifications applicable at the time of sale in accordance with its standard warranty. Testing and other quality control techniques are used to the extent it deems necessary to support this warranty. Except where mandated by government requirements, testing of all parameters of each product is not necessarily performed.

On-Bright Electronics Corp. assumes no liability for application assistance or customer product design. Customers are responsible for their products and applications using On-Bright's components, data sheet and application notes. To minimize the risks associated with customer products and applications, customers should provide adequate design and operating safeguards.

LIFE SUPPORT

On-Bright Electronics Corp.'s products are not designed to be used as components in devices intended to support or sustain human life. On-bright Electronics Corp. will not be held liable for any damages or claims resulting from the use of its products in medical applications.

MILITARY

On-Bright Electronics Corp.'s products are not designed for use in military applications. On-Bright Electronics Corp. will not be held liable for any damages or claims resulting from the use of its products in military applications.