

电路图
CIRCUIT DIAGRAM

H	
4.3	4.5
5.0	5.5
6.0	6.5
7.0	7.5
8.0	8.5
9.0	9.5

主要技术规格:

1. 额定值: 50mA DC12V
2. 接触电阻: ≤50mΩ
3. E(操作力): 250±40gf
4. 行程: 0.25±0.1mm
5. 绝缘电阻: ≥100MΩ
6. 抗电强度: 250V 50HZ 1Min.
7. 寿命: 100,000 Cycles
8. 防水等级: IP67
9. 防银迁移: 60V, 85°C, 90%RH/60H

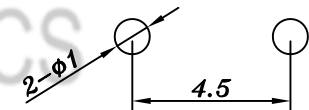
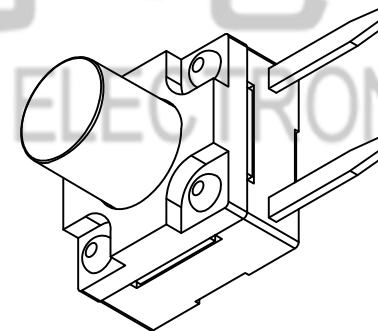
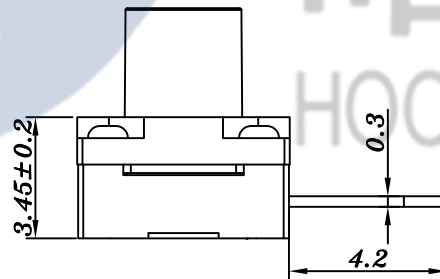

PCB. 焊接图
PCB. WELDING DRAWING

操作力 : E=250 ± 50gf

					TOLERANCE UNLESS SPECIFIED									
					UP TO 5mm: ±0.1	ANGULAR								
					ABOVE 5mm: ±0.2	±1°	1							
					NO	DATE	REVISIONS			BY	APPD			
6	CONTACT	BRASS	2	Ag-Plated	TITLE: TACT SWITCH		UNIT : MM	ROHS COMPLIANT	DWN					
5	CASE	PPA	1	BLACK	MODEL: TC-00104AF-060E		SCALE: 1:1	CHK'D						
4	REED	SUS	1	Ag-Plated	HAUYU(HONGKONG)LIMITED 皓宇(香港)有限公司							APPD		
3	WATERPROOF PAD	RUBBER	1	BLACK								PRO.AGL:		REV :A0
2	COVER	PPA	1	BLACK										
1	BUTTON	PPA	1	BLACK										
NO.	PART	NAME	MATERIAL	QTY	FINISHING									