

ROHS compliant

REV.	ECN NO.	DRAWN	DATE

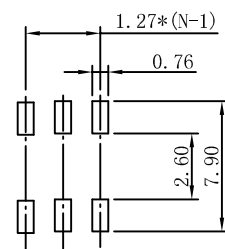

[P.C.B. LAYOUT]

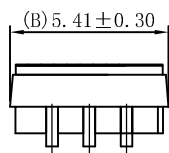
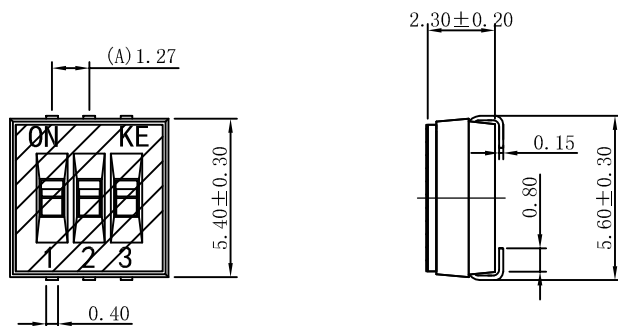
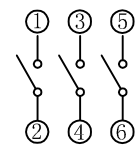

[Schematic]

**NOTES:**

**1.Specification:**

- 1>. Operation force: 1000gf Max.
- 2>. Operation Temperature: -30 °C to +85 °C.
- 3>. Storage Temperature: -40 °C to +85 °C.
- 4>. Mechanical Life: 1000 cycles operations.
- 5>. Resistance to Soldering: 260 ± 5 °C for 3-5 Seconds.

**2.PLATING:**

- 1>. GOLD flash 1u" (min) SOLDER TAIL,
- 3u" GOLD PLATING ON THE CONTACT AREA.

**3.ELECTRICAL:**

- 1>. Non-switch Rating: 100mA at 50V DC.
- 2>. Switching Rating: 25mA at 24V DC.
- 3>. Contact Resistance: Initial 50mΩ Max.  
Contact Resistance: After life 100mΩ Max.
- 4>. Insulation Resistance: 100MΩ Min at 100VDC.
- 5>. Dielectric Strength: 300V AC for 60seconds.
- 6>. Switch Capacitance: 5PF Max at 1MHZ.

**4.PART NUMBER DESCRIPTION:**

DSHP XX T S G E R

- (包装方式: T=Tub R=Reel)
- (电镀层: E=接触位3u"/焊接位1-2u")
- (电镀层: G=端子内外电镀全金)
- (端脚型: S=贴片 / H=插件 / J型)
- (L=高柄 / S=低柄 / T=低柄贴片)
- (开关位数: 02位-----10位)

**5.PACKING:** 2000pcs/Reel/Box.

东莞市康深电子科技有限公司  
Kongshen Electronics technology co., LTD.

Drawing	dengkg	Date	2017. 03. 24	LINER	ANGLES	PRODUCT Family DSHP Series Pitch 1.27mm	
Check	zhong	Scale	4:1	>0±0.05	>0° ±0.5°	PRAT NO.	DSHP03TJGER
Approved		Unit	MM	>1±0.10	>5° ±1.0°	FILE NO.	DSHP-003-J-A
Size	A4	Rev.	A	>10±0.30		PROJECTION	