



THINKING ELECTRONIC INDUSTRIAL CO., LTD.

HEAD OFFICE: 12F, No.93, Dashun 1st Rd., Zuoying Dist., Kaohsiung, Taiwan
TEL: 886-7-5577660 FAX: 886-7-5570560

MANUFACTURING SITE

- KAOHSIUNG FACTORY 1: No. 51, Kaifa Rd., N.E.P.Z, Kaohsiung City 81170, Taiwan
TEL: 886-7-9616668 FAX: 886-7-9616698
- KAOHSIUNG FACTORY 2: No. 2-2, Xinjian S. Rd., N.E.P.Z., Kaohsiung City 81170, Taiwan
TEL: 886-7-9630001 FAX: 886-7-3635113
- CHANGZHOU FACTORY: No.6 Longmen Rd., Wujin High & New-Tech Industrial
Development Zone, Changzhou, Jiangsu, China 213161
TEL:86-519-86578999 FAX:86-519-86558643
- DONG GUAN FACTORY: No.45, East Rd., Sha-Tao Dist., Chang-An Town,
Dongguan City, Guangdong, China 523863
TEL:86-769-85542016 FAX:86-769-85546890
- YICHANG FACTORY: No. 283 Xiaoting Avenue, Xiaoting Dist., Yichang
City 443007, Hubei, China
TEL:86-717-6510010 FAX:86-717-6511430



SPECIFICATION FOR APPROVAL

CUSTOMER	立創電子
CERTIFIED MODEL/TYPE	KMC4S150
PART NO.	KMC4S150RY(RoHS+HF)
APPLICATION	
CUSTOMER P/N	
ISSUE DATE	Jul.06.2022
REV. NO.	
REV. DATE	

FOR CUSTOMER APPROVAL	CHECKED BY
	<i>Haili Gong</i>
	APPROVED BY
	<i>Huaifang Zhang</i>





REVISED RECORD SHEET

REV. NO	REV. DATE	REVISED CONTENT

INDEX	Page
■ Part Number Code	1
■ Structure and Dimensions	2
■ Electrical Characteristics	2
■ Reliability	3
■ Soldering Recommendation	4
■ Typical Time-to-Trip Curves at 23°C	5
■ Thermal Derating Curve	5
■ RoHS Compliant Declaration	6
■ Warehouse Storage Conditions of Products	6
■ Safety Approvals	7
■ Certificates	7
■ Packaging	8



Part Number Code

Example :

K **MC** **4** **S** **150** **R** **Y**
(1) (2) (3) (4) (5) (6) (7)

No.	Item	Digit	Specification
(1)	Product Type	K	Thinking Polymer PTC Resettable Fuse
(2)	Type Series	MC	SMD series
(3)	Size (EIA)	4	1210
(4)	Structure	S	S type
(5)	I hold	150	1.5A @ 23°C
(6)	Packaging	R	Taping & Reel
(7)	Optional Suffix	Y	RoHS+HF compliance

Structure and Dimensions

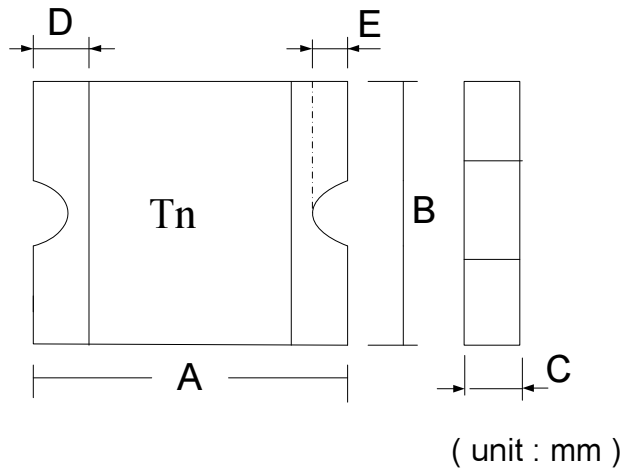

Item	A	B	C	D	E
MIN.	3.00	2.35	0.45	0.125	0.08
MAX.	3.43	2.80	1.00	0.75	0.50

Electrical Characteristics (23 °C)

Part No.	V max.	I max.	I hold @ 23°C	I trip @ 23°C	Pd (Max.)
	(V)	(A)	(A)	(A)	(W)
KMC4S150RY	6	100	1.50	3.00	0.80

Part No.	Max.time to trip		Resistance (Ω)		Operating / storage temperature
			Initial (Ri)	Post trip (R1)	
	(A)	(Sec.)	min.	max.	(°C)
KMC4S150RY	8.0	0.50	0.04	0.11	-40 ~ +85

Ihold=Hold current :maximum current device will pass without interruption at 23°C still air unless otherwise specified.

Itrip=Trip current :minimum current that will switch the device from low resistance to high resistance at 23°C still air unless otherwise specified.

Vmax=Maximum voltage device can withstand without damage at rated current.

Imax=Maximum current device can withstand without damage at rated voltage .

Pd=Power dissipated from device while the tripped state at 23°C still air unless otherwise specified.

Rimin=Minimum resistance of device prior to tripping at 23°C .

R1max=Maximum resistance of the device one hour after tripping at 23°C .

Caution:Operation beyond the specified rating or improper use may result in damage and possible arcing and flame.

Reliability

Item	Standard	Test conditions/Methods	Specifications
Passive Aging	IEC60738-1	85±5°C, 1000±24hrs	±10% typical resistance change
Humidity Aging	Specification Standard	85±5°C, 80~85%RH, 100±5hrs	±5% typical resistance change
Rapid Change of Temperature	IEC60738-1	85±5/-40±5°C, 20 cycles Duration:30min	-33% typical resistance change
Overload Endurance	UL1434	Vmax,120% Imax ,50 cycles + Vmax,300% Itrip ,6000 cycles	No arcing or burning
Aging	UL1434	Vmax, Itrip ≤ I ≤ Imax , 1000±24hrs	No arcing or burning
Solderability	IEC60068-2-58	245 ± 5 °C , 3 ± 0.3 sec	At least 95% of terminal electrode is covered by new solder

Soldering Recommendation

■ IR-Reflow Soldering Profile

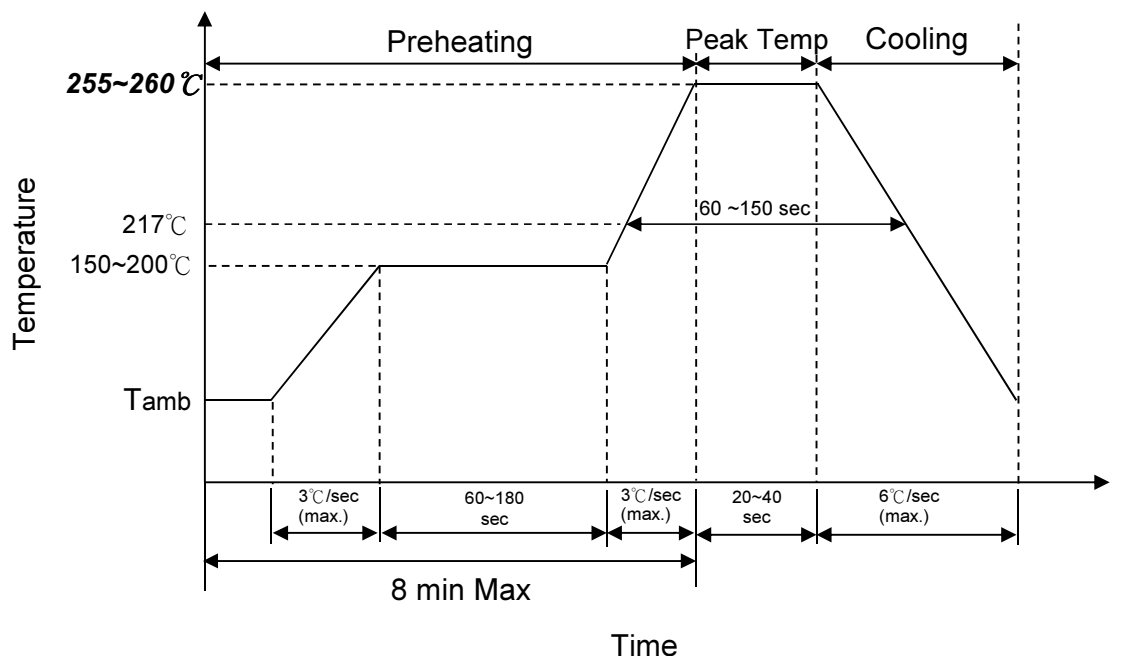

The welding method of the product is reflow welding, wave soldering is not recommended

* Recommended reflow methods: IR, Vapor phase, hot air oven.

* Devices can be cleaned using standard industry methods and solvents.

Notes:

If reflow temperatures exceed the recommended profile, devices may not meet the performance requirements.

Devices are not designed to be wave soldered to the bottom side of the board.

■ Recommended Reworking Conditions with Soldering Iron

Item	Conditions
Temperature of Soldering Iron-tip	360 °C (max.)
Soldering Time	3 sec (max.)
Diameter of Soldering Iron-tip	φ 3 mm (max.)

■ Recommended Soldering Pad Dimensions (Nominal)

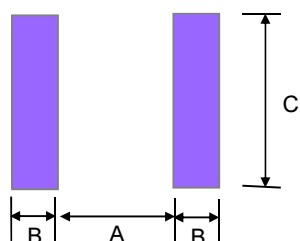

(Unit : mm)

SIZE	A	B	C
1210	2.00	1.00	2.80

Typical Time- to-Trip Curves at 23 °C

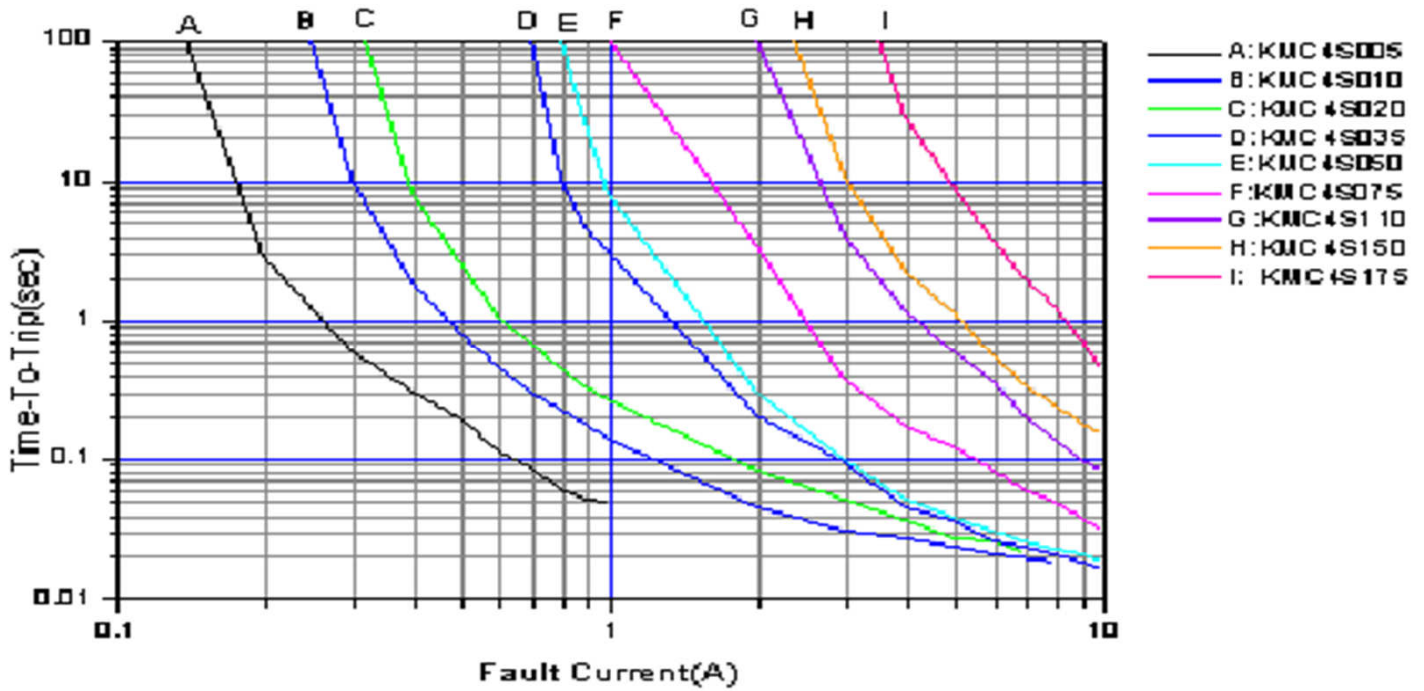

Thermal Derating Curve

Thermal derating curve for SMD 1210 series

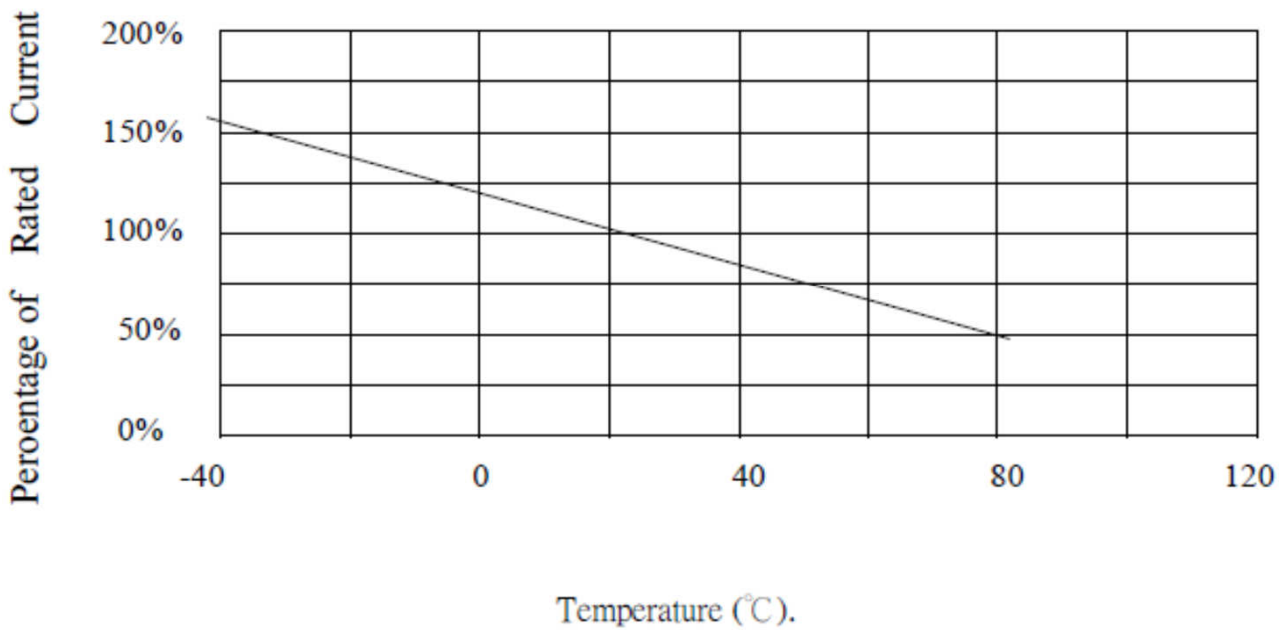

Model	Ambient Operation Temperature								
	-40°C	-20°C	0°C	23°C	40°C	50°C	60°C	70°C	85°C
KMC4S150	2.13	1.92	1.71	1.5	1.26	1.14	1.01	0.89	0.71

RoHS Compliant Declaration

We hereby declare that the components delivered to your company are compliant with RoHS directive 2015/863/EU.

Warehouse Storage Conditions of Products

(I) Storage Conditions :

- 1.Storage Temperature : $-10^{\circ}\text{C} \sim +40^{\circ}\text{C}$
- 2.Relative Humidity : $\leq 75\% \text{RH}$
- 3.Keep away from corrosive atmosphere and sunlight.

(II) Period of Storage : 1 year



Safety Approvals (Certified Model/Type :KMC4S150)



* UL 1434 / cUL recognized (File # E138827)



* TUV recognized (File # R50143386)

Certificates

- (1) IATF 16949 certificate
- (2) ISO 9001 certificate

Test Report

- (1) RoHS test report
- (2) Halogen-free test report



Packaging

■ Taping specification (1210 type)

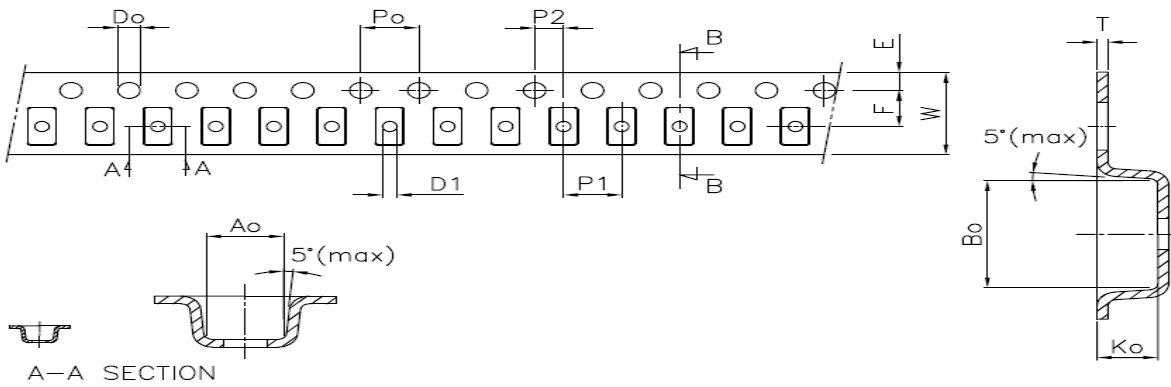

INDE	A0	B0	K0	P0	P1	P2	T	E	F	D0	D1	W	10P0
Type	+/-0.1	+/-0.1	+/-0.05	+/-0.1	+/-0.1	+/-0.1	+/-0.05	+/-0.1	+/-0.1	+/-0.05	min	+/-0.3	+/-0.2
1210	2.82	3.63	1.47	4.00	4.00	2.00	0.23	1.75	3.50	1.55	1.00	8.0	40.00

■ Quantity (3000 pcs / reel)

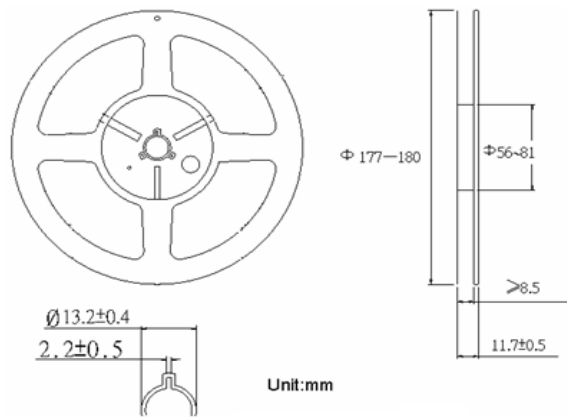

图1