

### Description

The BP0405SCG uses advanced trench technology to provide excellent  $R_{DS(ON)}$  and low gate charge. The complementary MOSFETs can be used in a wide variety of applications.



### Features

- N-Channel  
 $V_{DS}=40V, I_D=6A$   
 $R_{DS(ON)} < 26m\Omega @ V_{GS}=10V$
- P-Channel  
 $V_{DS}=-40V, I_D=-5A$   
 $R_{DS(ON)} < 60m\Omega @ V_{GS}=-10V$
- High power and current handling capability

### Applications

- H-bridge
- Inverters

### Typical Application

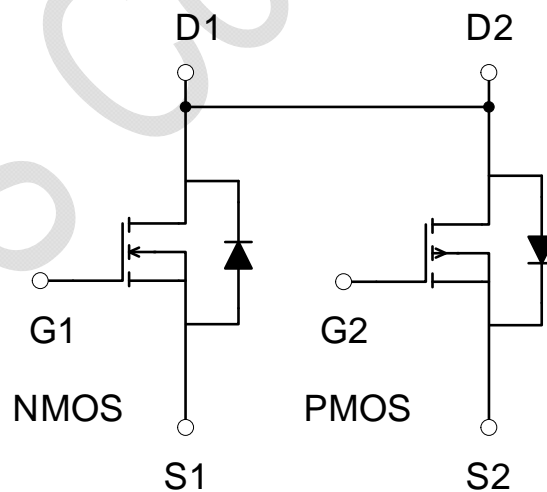

Figure 1. Schematic Diagram

### Ordering Information

Part Number	Package	Package Method	Marking
BP0405SCG	ESOP8	Tape 4,000 pcs/Reel	BP0405 XXXXXXSC XXWWG

### Pin Configuration and Marking Information

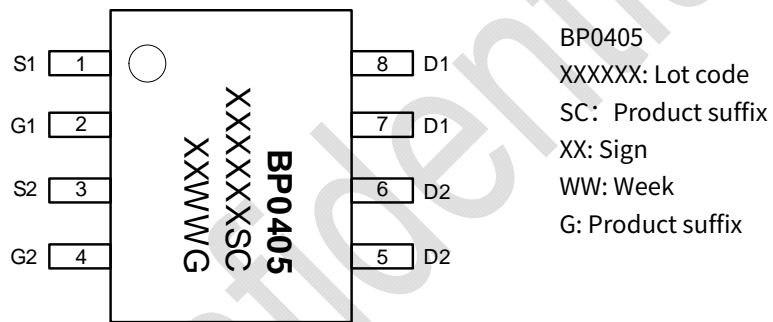

Figure2 : Pin configuration

### Pin Definition

Pin No.	Name	Description
1	S1	NMOS Source
2	G1	NMOS Gate
3	S2	PMOS Source
4	G2	PMOS Gate
5、6	D2	PMOS Drain
7、8	D1	NMOS Drain

**Absolute Maximum Ratings** (Note 1)

Symbol	Parameters		Range		Units
			N-Channel	P-Channel	
V <sub>GS</sub>	Gate-Source Voltage		±20	±20	V
V <sub>DS</sub>	Drain-Source Voltage		40	-40	V
V <sub>GS</sub>	Gate-Source Voltage		±20	±20	V
I <sub>D</sub>	Continuous Drain Current	T <sub>C</sub> =25°C	6.5	-5.5	A
		T <sub>C</sub> =70°C	4.5	-3.8	
I <sub>DM</sub>	Pulsed Drain Current (note 2)		35	-22	A
P <sub>D</sub>	Maximum Power Dissipation	T <sub>C</sub> =25°C	2	2	W
T <sub>J</sub> ,T <sub>STG</sub>	Operating Junction and Storage Temperature Range		-55 to 150	-55 to 150	°C
R <sub>θJA</sub>	Thermal Resistance, Junction-to-Ambient (note 3)		62.5	62.5	°C/W

**Note 1:** Stresses beyond those listed under “absolute maximum ratings” may cause permanent damage to the device. Under “recommended operating conditions” the device operation is assured, but some particular parameter may not be achieved. The electrical characteristics table defines the operation range of the device, the electrical characteristics is assured on DC and AC voltage by test program. For the parameters without minimum and maximum value in the EC table, the typical value defines the operation range, the accuracy is not guaranteed by spec.

**Note 2:** Repetitive Rating: Pulse width limited by maximum junction temperature.

**Note 3:** Surface Mounted on FR4 Board,  $t \leq 10$  sec.

**N-Channel Electrical Characteristics** (Notes 4, 5) (Unless otherwise specified,  $T_A=25\text{ }^\circ\text{C}$ )

Symbol	Parameter	Condition	Min	Typ	Max	Unit
Off Characteristics						
$B_{V_{DS}}$	Drain-Source Breakdown Voltage	$V_{GS}=0V, I_D=250\mu A$	40	-	-	V
$I_{DSS}$	Zero Gate Voltage Drain Current	$V_{DS}=40V, V_{GS}=0V$	-	-	1	$\mu A$
$I_{GSS}$	Gate-Body Leakage Current	$V_{GS}=\pm 20V, V_{DS}=0V$	-	-	$\pm 100$	nA
On Characteristics (Note 6)						
$V_{GS(th)}$	Gate Threshold Voltage	$V_{DS}=V_{GS}, I_D=250\mu A$	1.3	1.6	1.9	V
$R_{DS(ON)}$	Drain-Source On-State Resistance	$V_{GS}=10V, I_D=6A$	-	22	26	m $\Omega$
$g_{FS}$	Forward Transconductance	$V_{DS}=5V, I_D=6A$	33	-	-	S
Dynamic Characteristics (Note7)						
$C_{iss}$	Input Capacitance	$V_{DS}=20V, V_{GS}=0V,$ $F=1.0MHz$	-	310	-	pF
$C_{oss}$	Output Capacitance		-	80	-	pF
$C_{rss}$	Reverse Transfer Capacitance		-	50	-	pF
Switching Characteristics (Note 7)						
$t_{d(on)}$	Turn-on Delay Time	$V_{DD}=20V, R_L=2.5\Omega$ $V_{GS}=10V, R_{GEN}=3\Omega$	-	4	-	ns
$t_r$	Turn-on Rise Time		-	3	-	ns
$t_{d(off)}$	Turn-Off Delay Time		-	15	-	ns
$t_f$	Turn-Off Fall Time		-	2	-	ns
$Q_g$	Total Gate Charge	$V_{DS}=20V, I_D=6A,$ $V_{GS}=10V$	-	8.5	-	nC
$Q_{gs}$	Gate-Source Charge		-	2.2	-	nC
$Q_{gd}$	Gate-Drain Charge		-	2.1	-	nC
Drain-Source Diode Characteristics						
$V_{SD}$	Diode Forward Voltage (Note 6)	$V_{GS}=0V, I_S=6A$	-	0.82	1.2	V

**P-Channel Electrical Characteristics** (Notes 4, 5) (Unless otherwise specified,  $T_A = 25^\circ\text{C}$ )

Symbol	Parameter	Condition	Min	Typ	Max	Unit
Off Characteristics						
$B_{V_{DS}}$	Drain-Source Breakdown Voltage	$V_{GS}=0V, I_D=-250\mu A$	-40	-	-	V
$I_{DSS}$	Zero Gate Voltage Drain Current	$V_{DS}=-40V, V_{GS}=0V$	-	-	-1	$\mu A$
$I_{GSS}$	Gate-Body Leakage Current	$V_{GS}=\pm 20V, V_{DS}=0V$	-	-	$\pm 100$	nA
On Characteristics (Note 6)						
$V_{GS(th)}$	Gate Threshold Voltage	$V_{DS}=V_{GS}, I_D=-250\mu A$	-1.5	-1.9	-2.3	V
$R_{DS(ON)}$	Drain-Source On-State Resistance	$V_{GS}=-10V, I_D=-5A$	-	50	60	m $\Omega$
$g_{FS}$	Forward Transconductance	$V_{DS}=-5V, I_D=-5A$	20	-	-	S
Dynamic Characteristics (Note7)						
$C_{iss}$	Input Capacitance	$V_{DS}=-20V, V_{GS}=0V,$ $F=1.0MHz$	-	370	-	pF
$C_{oss}$	Output Capacitance		-	72	-	pF
$C_{rss}$	Reverse Transfer Capacitance		-	52	-	pF
Switching Characteristics (Note 7)						
$t_{d(on)}$	Turn-on Delay Time	$V_{DD}=-20V, R_L=2.5\Omega$ $V_{GS}=-10V, R_{GEN}=3\Omega$	-	7.5	-	ns
$t_r$	Turn-on Rise Time		-	5.5	-	ns
$t_{d(off)}$	Turn-Off Delay Time		-	19	-	ns
$t_f$	Turn-Off Fall Time		-	7	-	ns
$Q_g$	Total Gate Charge		-	8.5	-	nC
$Q_{gs}$	Gate-Source Charge		-	2.6	-	nC
$Q_{gd}$	Gate-Drain Charge	-	2.1	-	nC	
Drain-Source Diode Characteristics						
$V_{SD}$	Diode Forward Voltage (Note 6)	$V_{GS}=0V, I_S=-5A$	-	-0.9	-1.2	V

**Note 4:** Production testing of the chip is performed at  $25^\circ\text{C}$ .

**Note 5:** The maximum and minimum parameters specified are guaranteed by test, the typical value are guaranteed by design, characterization and statistical analysis.

**Note 6:** Pulse Test: Pulse Width  $\leq 300\mu s$ , Duty Cycle  $\leq 2\%$ .

**Note 7:** Guaranteed by design, not subject to production

N-Channel Typical Electrical and Thermal Characteristics Curves

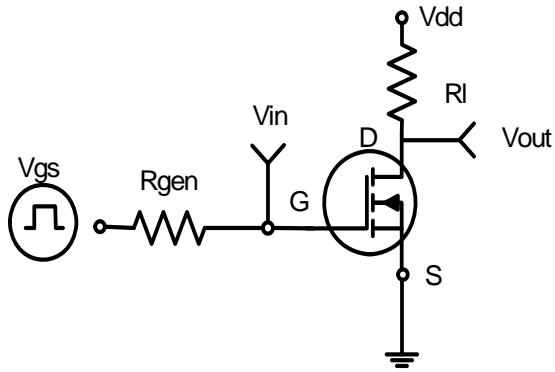

Figure 3. Switching Test Circuit

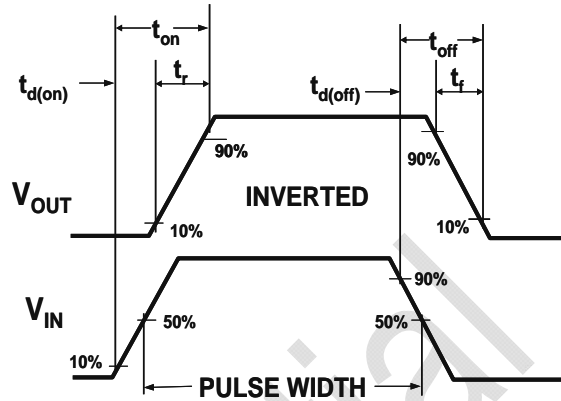

Figure 4. Switching Waveforms

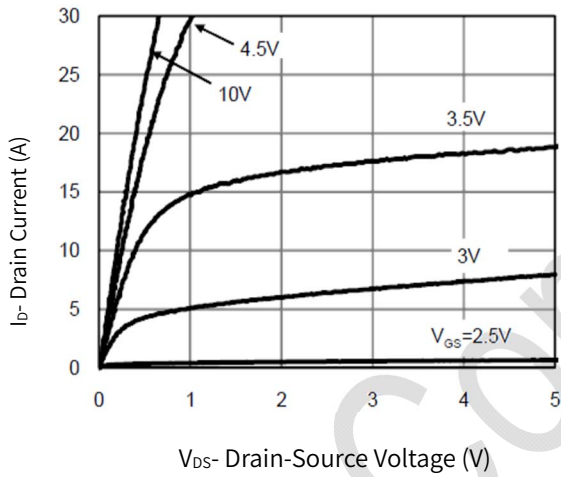

Figure 5. Output Characteristics

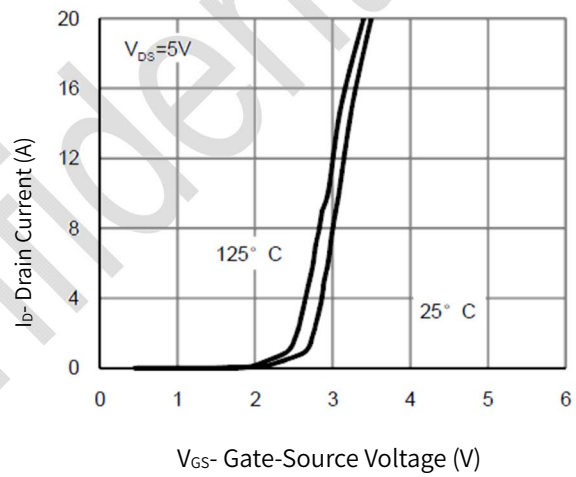

Figure 6. Transfer Characteristics

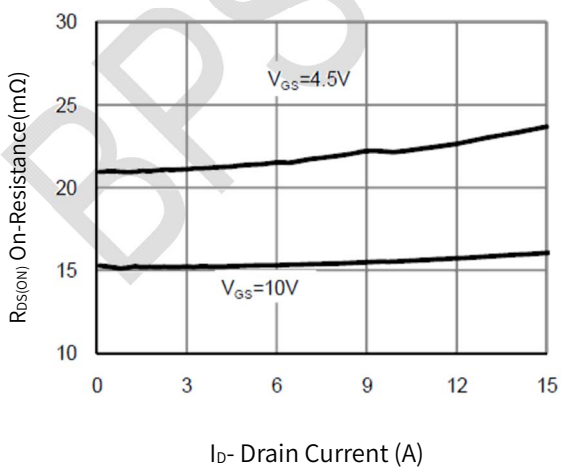

Figure 7. Drain-Source On-Resistance

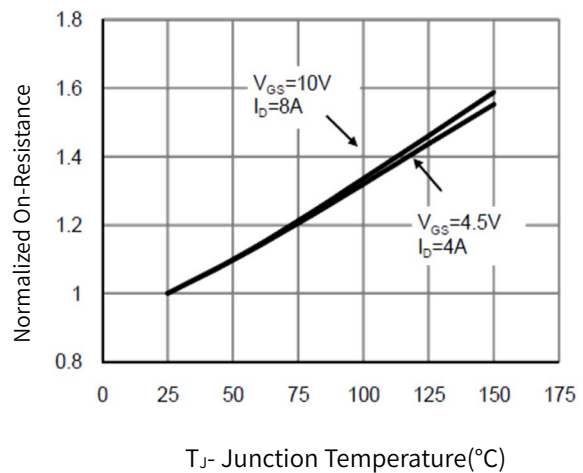

Figure 8. Drain-Source On-Resistance

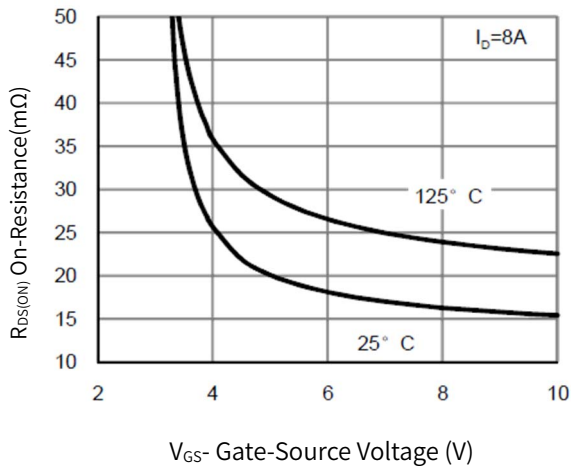

Figure 9.  $R_{DS(ON)}$  VS  $V_{GS}$

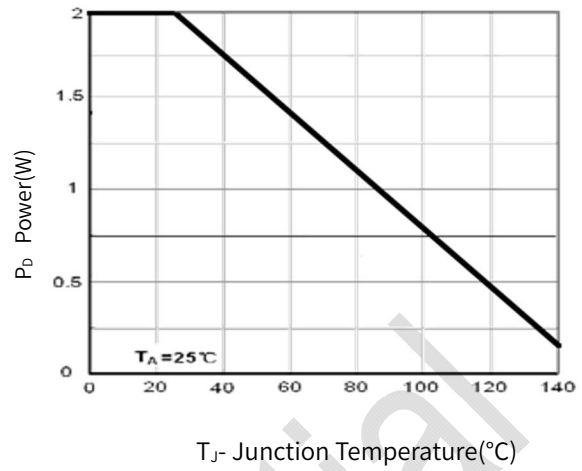

Figure 10. Power Dissipation

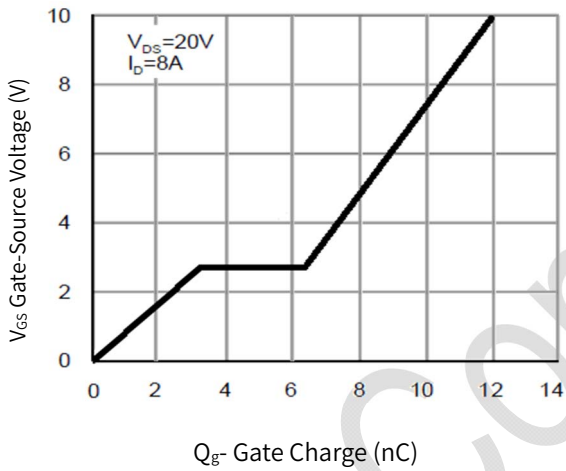

Figure 11 Gate Charge

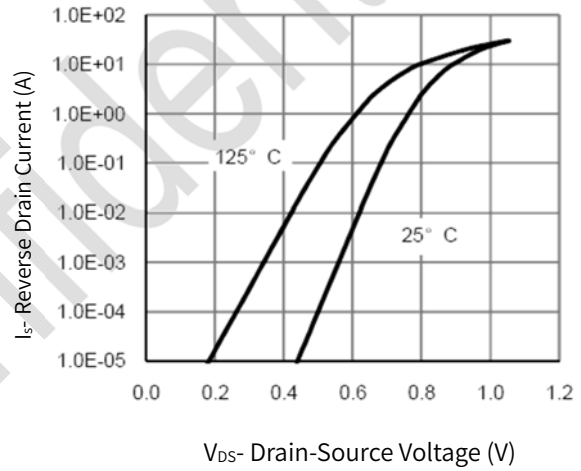

Figure 12. Source- Drain Diode Forward

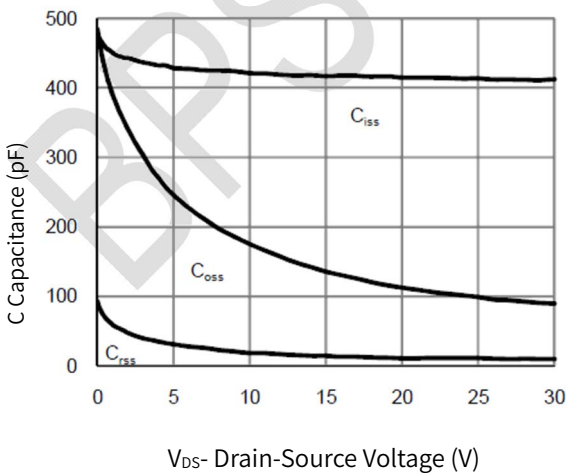

Figure 13. Capacitance vs  $V_{DS}$

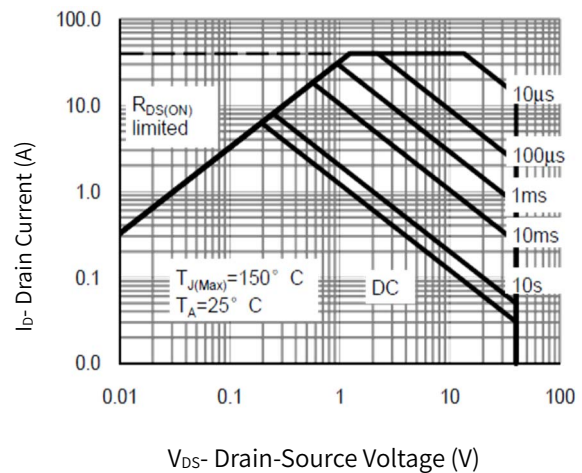

Figure 14. Safe Operation Area

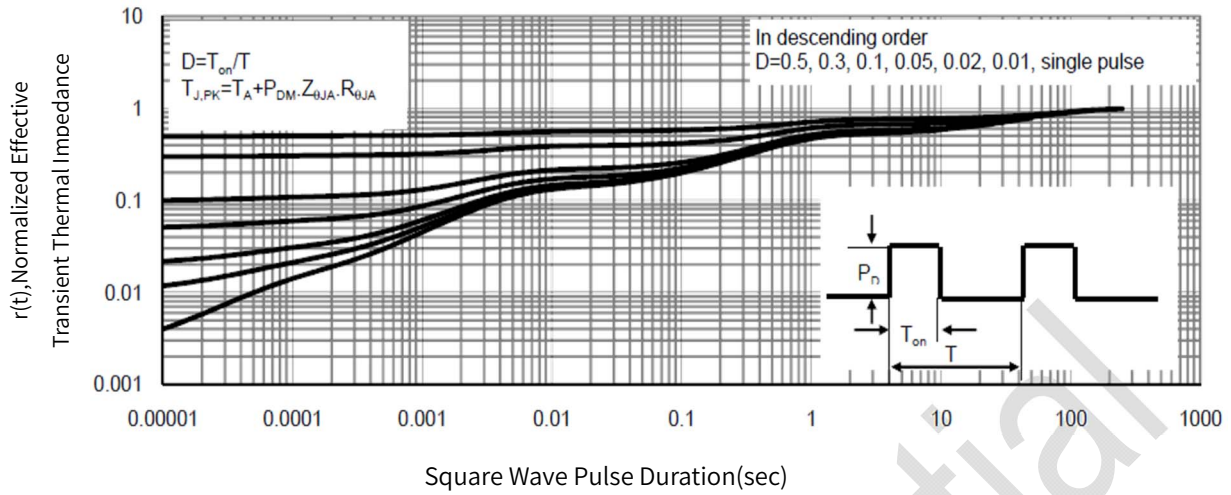

Figure 15. Normalized Maximum Transient Thermal Impedance

### P-Channel Typical Electrical and Thermal Characteristics Curves

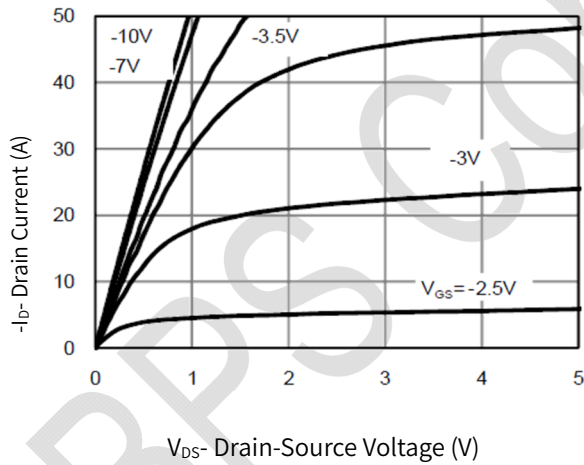

Figure 16. Output Characteristics

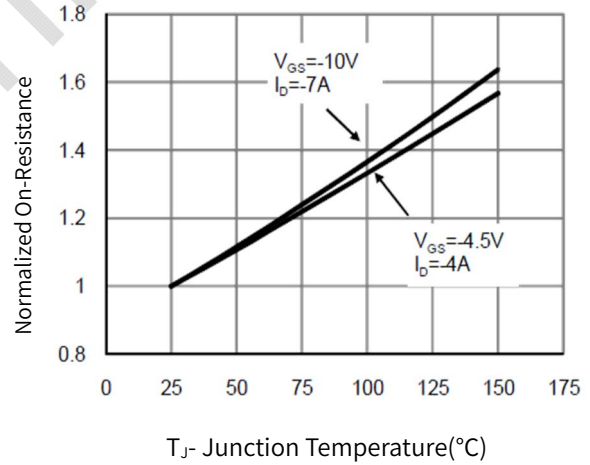

Figure 17.  $R_{DS(ON)}$ -Junction Temperature



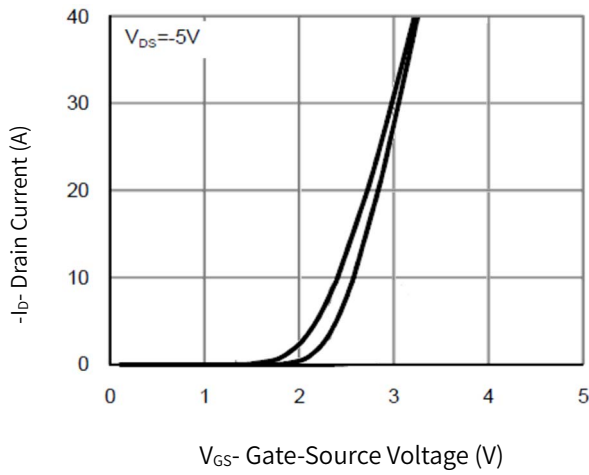

Figure 18. Transfer Characteristics

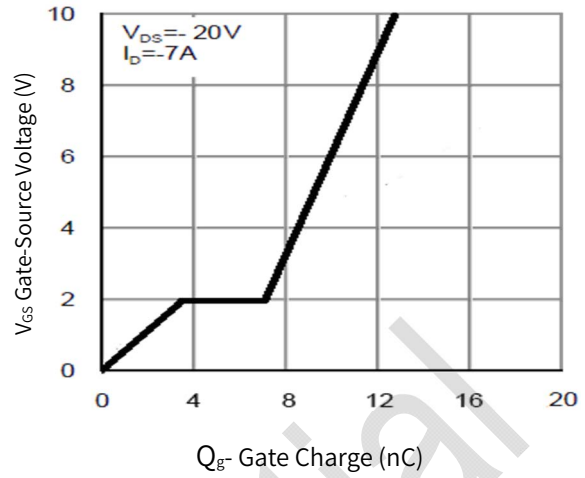

Figure 19. Gate Charge

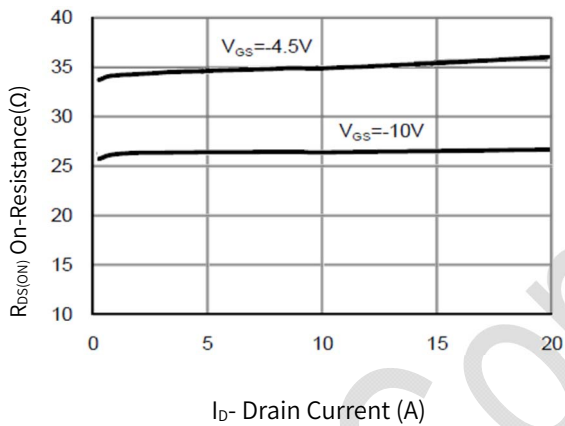

Figure 20.  $R_{DS(ON)}$ - Drain Current

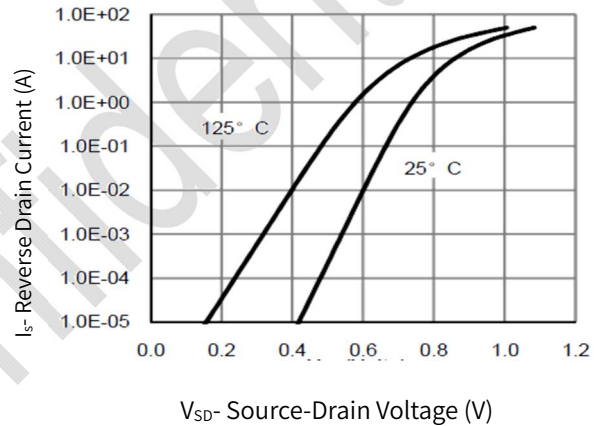

Figure 21. Source-Drain Diode Forward

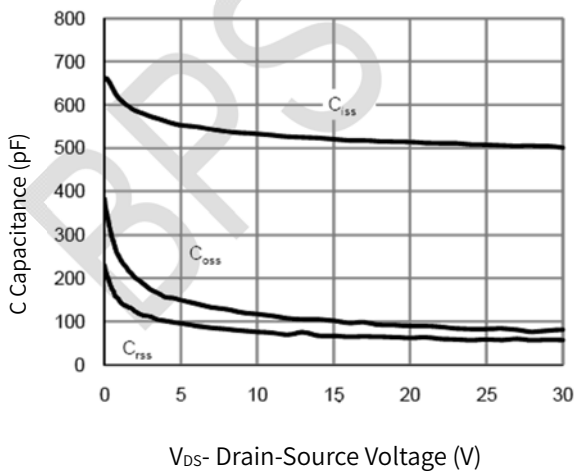

Figure 22. Capacitance vs  $V_{DS}$

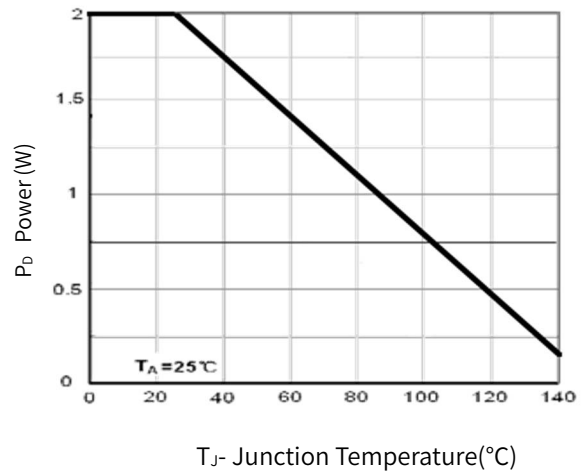

Figure 23. Power Dissipation

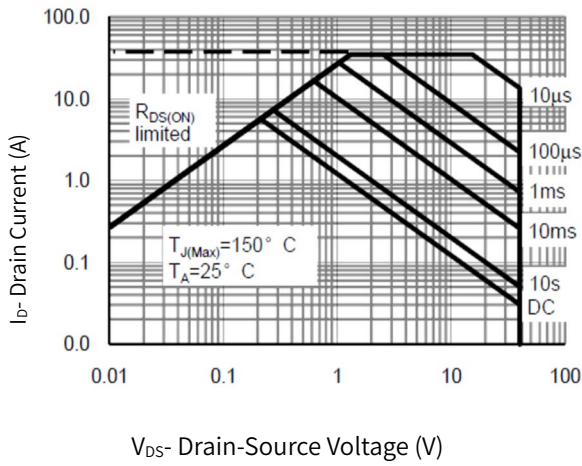

Figure 24. Safe Operation Area

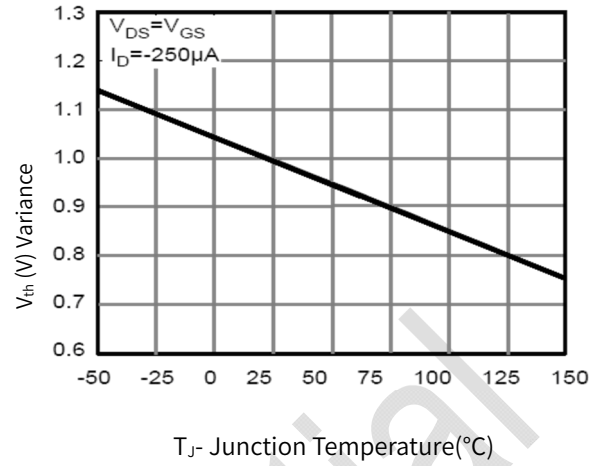

Figure 25.  $V_{GS(th)}$  vs. Junction Temperature

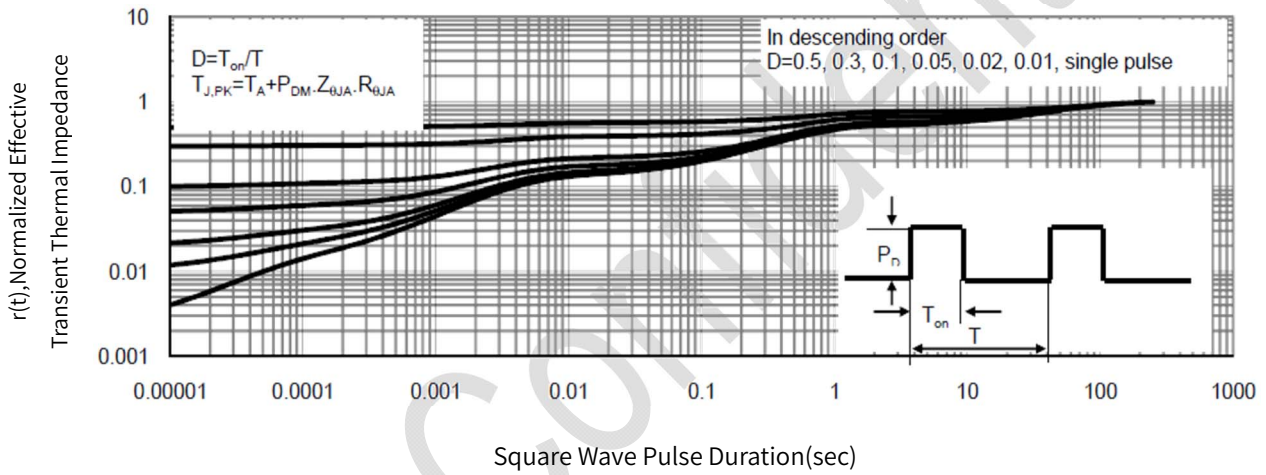
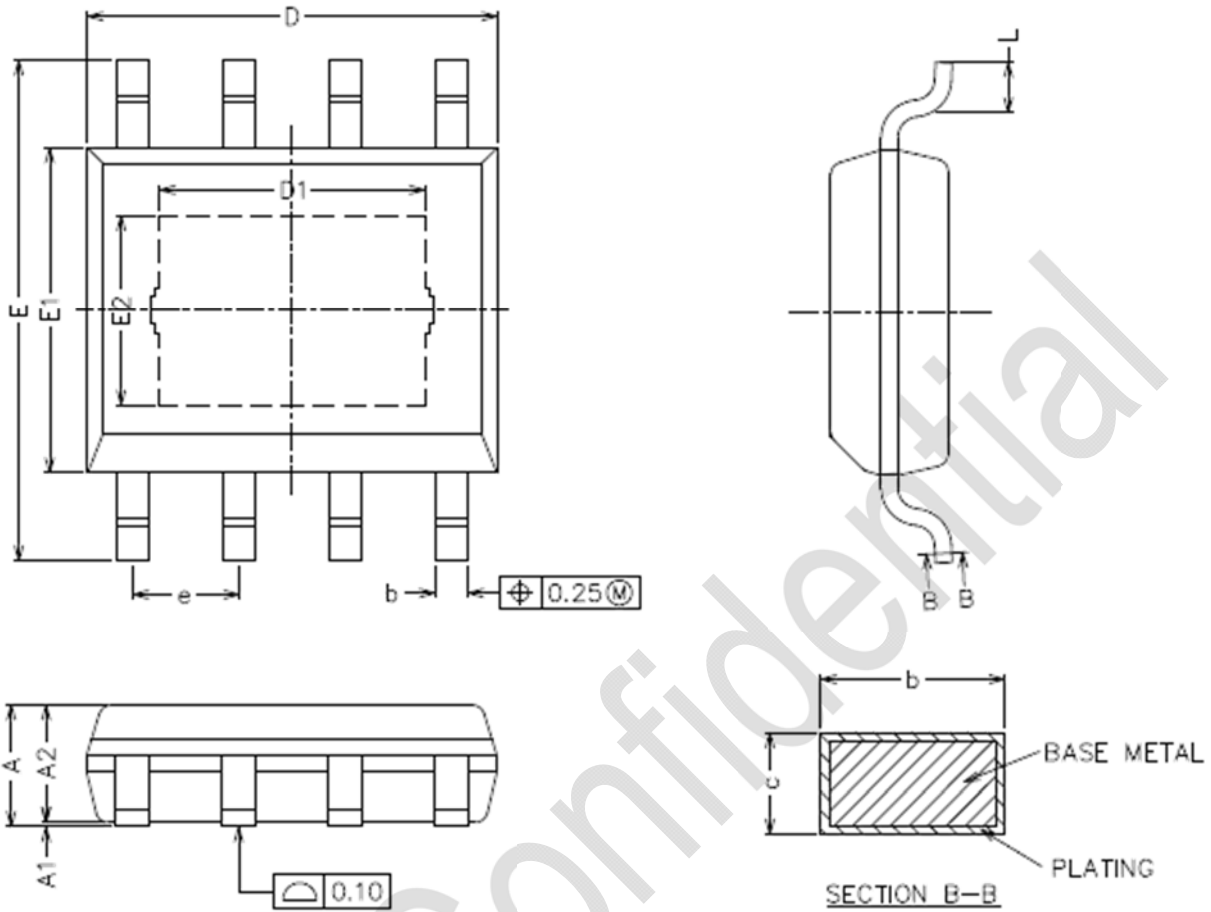

Figure 26. Normalized Maximum Transient Thermal Impedance

**Physical Dimensions**



SYMBOL	MILLIMETER		
	MIN	NOM	MAX
A	1.35	-	1.75
A1	0.00	-	0.15
A2	1.25	1.40	1.65
b	0.30	-	0.50
c	0.10	-	0.25
D	4.70	4.90	5.10
D1	3.02	-	3.50
E	5.80	-	6.40
E1	3.70	3.90	4.10
E2	2.10	-	2.60
L	0.40	0.60	1.25
e	1.17	1.27	1.37

Revision Information

Revision	Date	Notes

BPS Confidential

## Disclaimer

The information provided in this datasheet is believed to be accurate and reliable. However, Bright Power Semiconductor (BPS) reserves the right to make changes at any time without prior notice.

No license, to any intellectual property right owned by BPS or any other third party, is granted under this document. BPS provides information in this datasheet “AS IS” and with all faults, and makes no warranty, express or implied, including but not limited to, the accuracy of the information provided in this datasheet, merchantability, fitness of a specific purpose, or non-infringement of intellectual property rights of BPS or any other third party. BPS disclaims any and all liabilities arising out of this datasheet or use of this datasheet, including without limitation consequential or incidental damages.

BPS Confidential