

»Features

- Excellent clamping capability
- Low leakage current
- Low capacitance
- High surge capability
- Glass passivated chip
- Epoxy resin package
- Built-in strain relief
- Will not fatigue
- RoHS Compliant
- Fast response time:
typically less than 1.0ps from 0 Volts to V_{BR} min



SMB (DO-214AA)

»Mechanical Characteristics

- Package: SMB plastic package.
- Lead Finish: Matte Tin
- Case Material: Epoxy Molding Compound.
- UL Flammability Classification Rating 94V-0
- Moisture Sensitivity: Level 1 per J-STD-020

»Applications

- Telecom
- Computer
- Industrial electronic
- Consumer electronic

»Electrical Parameters

Parameter	Definition
C_J	Junction Capacitance - typical capacitance measured with 0V or V_R bias
I_{PP}	Peak Pulse Current - maximum rated peak impulse current
V_C	Clamping Voltage - Peak voltage measured across the suppressor at a specified I_{ppm} (peak impulse current)
V_{BR}	Breakdown Voltage - Maximum voltage that flows through the TVS at a specified test current (I_T)
I_R	Leakage Current - maximum peak off-state current measured at V_R
V_R	Peak Off-state Voltage - maximum voltage that can be applied while maintaining off state

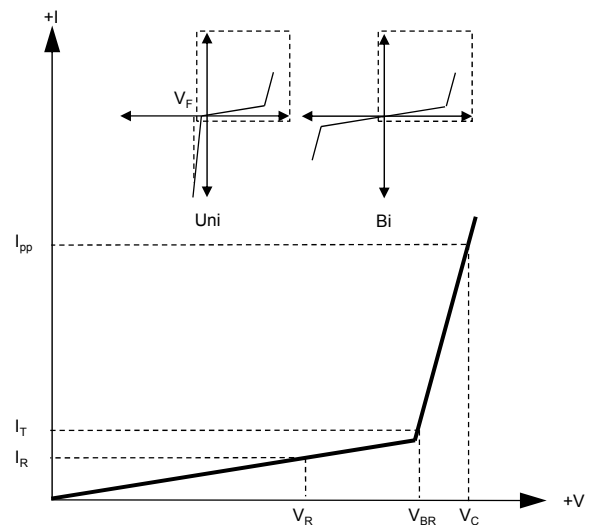

»Summary of Packing Options

Package	Packing Description	Packing Quantity	Industry Standard
SMB	Tape/Reel, 13" reel	3000	EIA-481-1
	Tape/Reel, 7" reel	500	EIA-481-1

»Absolute Maximum Ratings ($T_A=25^{\circ}\text{C}$ unless otherwise noted)

Parameter	Symbol	Value	Units	Remarks
Peak Pulse Power Dissipation	P_{PPM}	1000	W	(Note1)(Note2)
Steady State Power Dissipation	P_D	5	W	(Note3)
Peak Forward Surge Current	I_{FSM}	150	A	(Note4)
Maximum Instantaneous Forward Voltage at 50A	V_{FM}	3.5/5	V	(Note5)
Typical Thermal Resistance Junction to Lead	$R_{\theta JL}$	20	$^{\circ}\text{C}/\text{W}$	
Typical Thermal Resistance Junction to Ambient	$R_{\theta JA}$	100	$^{\circ}\text{C}/\text{W}$	
Operating Temperature Range	T_J	-55 to 150	$^{\circ}\text{C}$	
Storage Temperature Range	T_{STG}	-55 to 150	$^{\circ}\text{C}$	

Notes1: Non-repetitive current pulse , 10/1000us Waveform.

Notes2: Mounted on copper pad area of 5×5mm to each terminal.

Notes3: Infinite HeatSink at $T_A=50^{\circ}\text{C}$

Notes4: Measured on 8.3ms single half sine wave or equivalent square wave, duty cycle=4 perminute maximum.

Notes5: For UnidirectionalOnly, $V_{FM}<3.5\text{V}$ for $V_{BR} \leq 200\text{V}$ and $V_{FM}<5.0\text{V}$ for $V_{BR} \geq 201\text{V}$.

»Electrical Characteristics ($T_A=25^{\circ}\text{C}$ unless otherwise noted)

Part Number (Uni)	Part Number (Bi)	Marking Code		Reverse Stand off Voltage V_R (V)	Breakdown Voltage $V_{BR} @ I_T$ (V)		Test Current I_T (mA)	Maximum Clamping Voltage $V_C @ I_{PP}$ (V)	Maximum Peak Pulse Current I_{PP} (A)	Maximun Reverse Leakage $I_R @ V_R$ (μA)
		Uni	Bi		Min	Max				
1.0SMBJ5.0A	1.0SMBJ5.0CA	A5	C5	5	6.4	7	10	9.2	108.7	800
1.0SMBJ6.0A	1.0SMBJ6.0CA	A6	C6	6	6.67	7.37	10	10.3	97.1	800
1.0SMBJ6.5A	1.0SMBJ6.5CA	A6V	C6V	6.5	7.22	7.98	10	11.2	89.3	500
1.0SMBJ7.0A	1.0SMBJ7.0CA	A7	C7	7	7.78	8.6	10	12	83.3	200
1.0SMBJ7.5A	1.0SMBJ7.5CA	A7V	C7V	7.5	8.33	9.21	1	12.9	77.5	100
1.0SMBJ8.0A	1.0SMBJ8.0CA	A8	C8	8	8.89	9.83	1	13.6	73.5	50
1.0SMBJ8.5A	1.0SMBJ8.5CA	A8V	C8V	8.5	9.44	10.4	1	14.4	69.4	20
1.0SMBJ9.0A	1.0SMBJ9.0CA	A9	C9	9	10	11.1	1	15.4	64.9	10
1.0SMBJ10A	1.0SMBJ10CA	A10	C10	10	11.1	12.3	1	17	58.8	5
1.0SMBJ11A	1.0SMBJ11CA	A11	C11	11	12.2	13.5	1	18.2	54.9	1
1.0SMBJ12A	1.0SMBJ12CA	A12	C12	12	13.3	14.7	1	19.9	50.3	1
1.0SMBJ13A	1.0SMBJ13CA	A13	C13	13	14.4	15.9	1	21.5	46.5	1
1.0SMBJ14A	1.0SMBJ14CA	A14	C14	14	15.6	17.2	1	23.2	43.1	1
1.0SMBJ15A	1.0SMBJ15CA	A15	C15	15	16.7	18.5	1	24.4	41.0	1
1.0SMBJ16A	1.0SMBJ16CA	A16	C16	16	17.8	19.7	1	26	38.5	1
1.0SMBJ17A	1.0SMBJ17CA	A17	C17	17	18.9	20.9	1	27.6	36.2	1
1.0SMBJ18A	1.0SMBJ18CA	A18	C18	18	20	22.1	1	29.2	34.2	1
1.0SMBJ20A	1.0SMBJ20CA	A20	C20	20	22.2	24.5	1	32.4	30.9	1
1.0SMBJ22A	1.0SMBJ22CA	A22	C22	22	24.4	26.9	1	35.5	28.2	1
1.0SMBJ24A	1.0SMBJ24CA	A24	C24	24	26.7	29.5	1	38.9	25.7	1

»Electrical Characteristics ($T_A=25^\circ\text{C}$ unless otherwise noted)

Part Number (Uni)	Part Number (Bi)	Marking Code		Reverse Stand off Voltage V_R (V)	Breakdown Voltage $V_{BR} @ I_T$ (V)		Test Current I_T (mA)	Maximum Clamping Voltage $V_C @ I_{PP}$ (V)	Maximum Peak Pulse Current I_{PP} (A)	Maximun Reverse Leakage $I_R @ V_R$ (μA)
		Uni	Bi		Min	Max				
1.0SMBJ26A	1.0SMBJ26CA	A26	C26	26	28.9	31.9	1	42.1	23.8	1
1.0SMBJ28A	1.0SMBJ28CA	A28	C28	28	31.1	34.4	1	45.4	22.0	1
1.0SMBJ30A	1.0SMBJ30CA	A30	C30	30	33.3	36.8	1	48.4	20.7	1
1.0SMBJ33A	1.0SMBJ33CA	A33	C33	33	36.7	40.6	1	53.3	18.8	1
1.0SMBJ36A	1.0SMBJ36CA	A36	C36	36	40	44.2	1	58.1	17.2	1
1.0SMBJ40A	1.0SMBJ40CA	A40	C40	40	44.4	49.1	1	64.5	15.5	1
1.0SMBJ43A	1.0SMBJ43CA	A43	C43	43	47.8	52.8	1	69.4	14.4	1
1.0SMBJ45A	1.0SMBJ45CA	A45	C45	45	50	55.3	1	72.7	13.8	1
1.0SMBJ48A	1.0SMBJ48CA	A48	C48	48	53.3	58.9	1	77.4	12.9	1
1.0SMBJ51A	1.0SMBJ51CA	A51	C51	51	56.7	62.7	1	82.4	12.1	1
1.0SMBJ54A	1.0SMBJ54CA	A54	C54	54	60	66.3	1	87.1	11.5	1
1.0SMBJ58A	1.0SMBJ58CA	A58	C58	58	64.4	71.2	1	93.6	10.7	1
1.0SMBJ60A	1.0SMBJ60CA	A60	C60	60	66.7	73.7	1	96.8	10.3	1
1.0SMBJ64A	1.0SMBJ64CA	A64	C64	64	71.1	78.6	1	103	9.7	1
1.0SMBJ70A	1.0SMBJ70CA	A70	C70	70	77.8	86	1	113	8.8	1
1.0SMBJ75A	1.0SMBJ75CA	A75	C75	75	83.3	92.1	1	121	8.3	1
1.0SMBJ78A	1.0SMBJ78CA	A78	C78	78	86.7	95.8	1	126	7.9	1
1.0SMBJ85A	1.0SMBJ85CA	A85	C85	85	94.4	104	1	137	7.3	1
1.0SMBJ90A	1.0SMBJ90CA	A90	C90	90	100	111	1	146	6.8	1
1.0SMBJ100A	1.0SMBJ100CA	A100	C100	100	111	123	1	162	6.2	1
1.0SMBJ110A	1.0SMBJ110CA	A110	C110	110	122	135	1	177	5.6	1
1.0SMBJ120A	1.0SMBJ120CA	A120	C120	120	133	147	1	193	5.2	1
1.0SMBJ130A	1.0SMBJ130CA	A130	C130	130	144	159	1	209	4.8	1
1.0SMBJ150A	1.0SMBJ150CA	A150	C150	150	167	185	1	243	4.1	1
1.0SMBJ160A	1.0SMBJ160CA	A160	C160	160	178	197	1	259	3.9	1
1.0SMBJ170A	1.0SMBJ170CA	A170	C170	170	189	209	1	275	3.6	1

»Rating And Characteristic Curves ($T_A=25^\circ\text{C}$ unless otherwise noted)

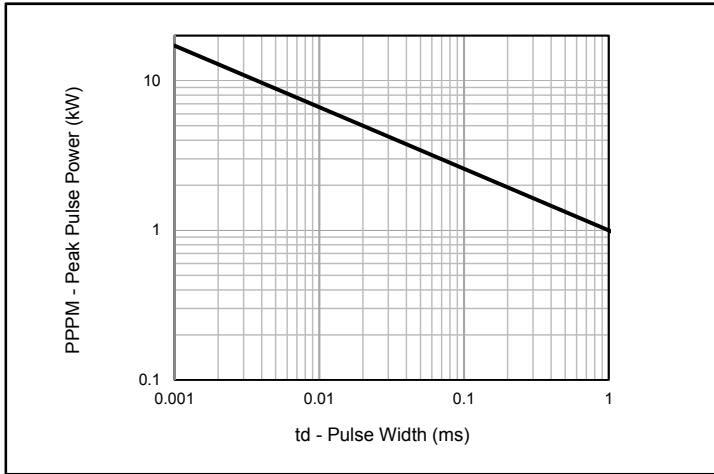

Fig.1 - Peak Pulse Power Rating

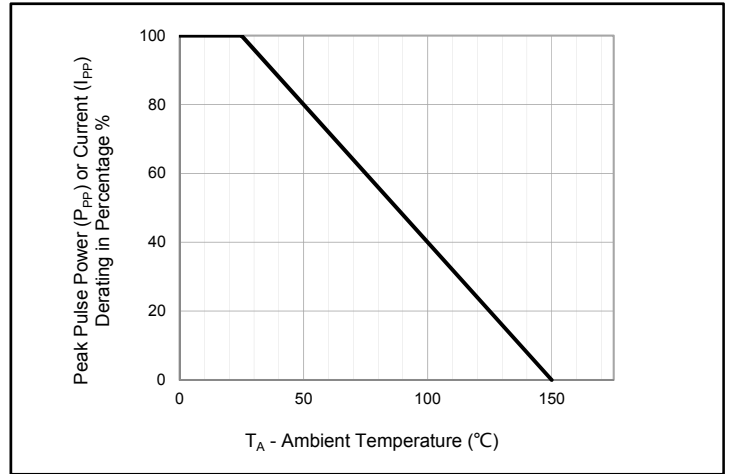

Fig.2 - Pulse Derating Curve

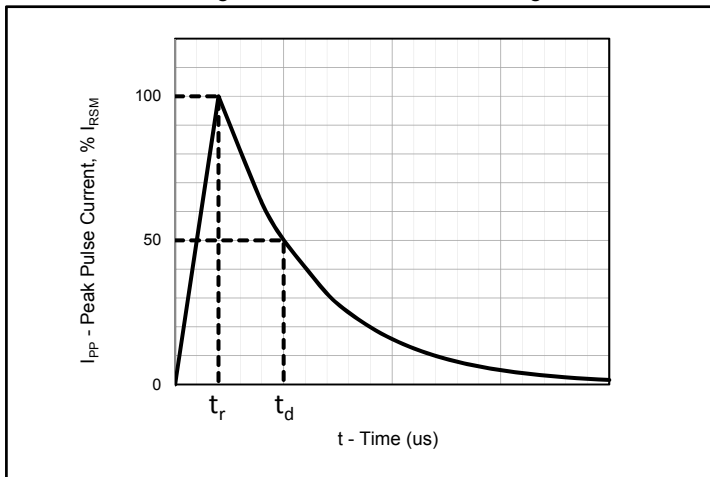

Fig.3 - Pulse Waveform

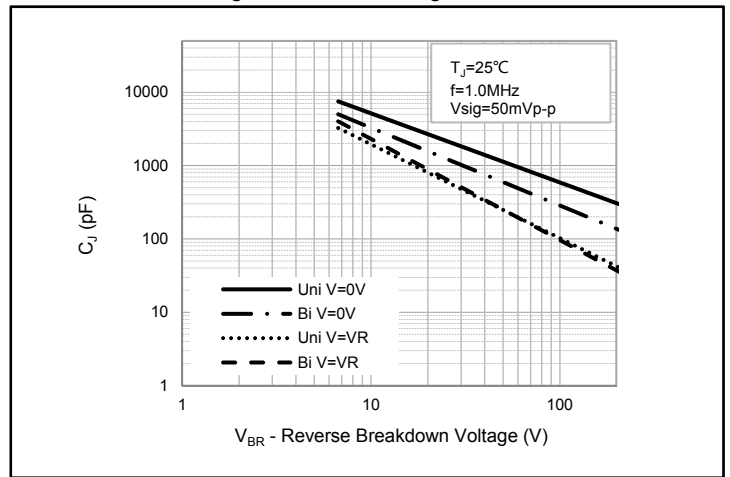

Fig.4 - Typical Junction Capacitance

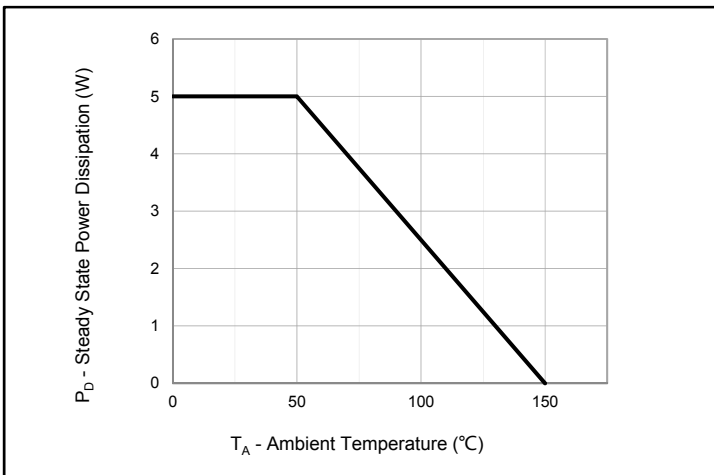

Fig.5 - Steady State Power Dissipation Derating Curve

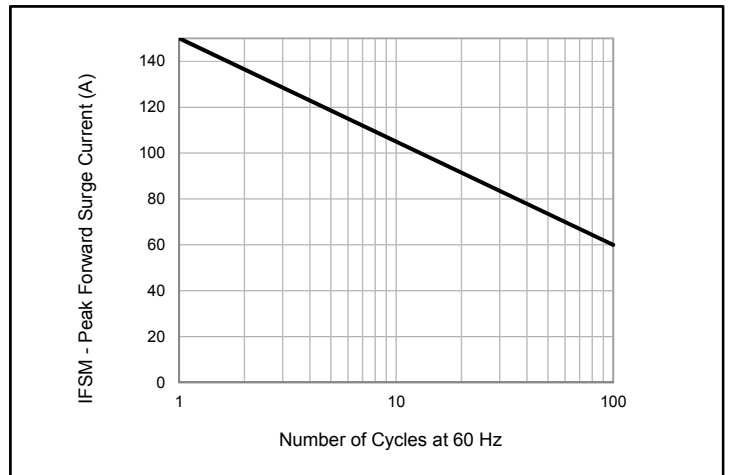
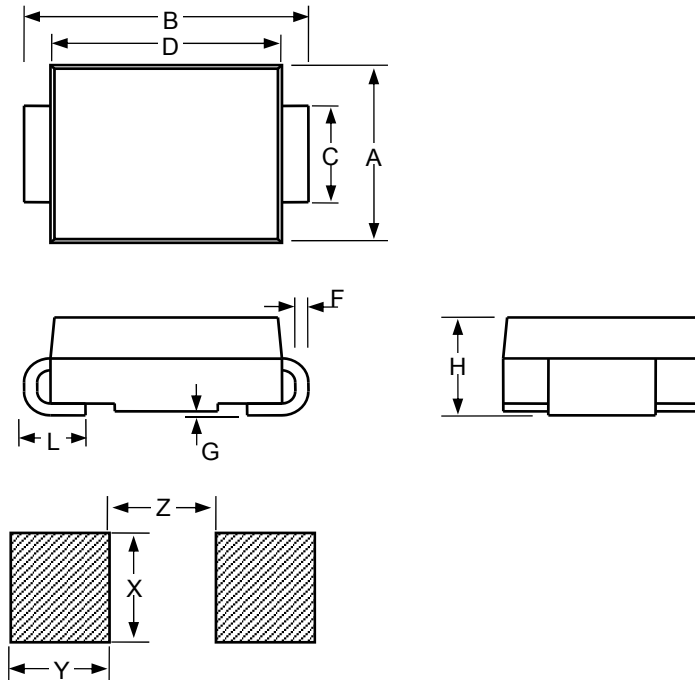

Fig.6 - Maximum Non-Repetitive Peak Forward Surge Current
Uni-Directional Only

»Package Dimensions



SMB						
Dimension	Inches			Millimeters		
	MIN	NOM	MAX	MIN	NOM	MAX
A	0.134	0.144	0.155	3.4	3.67	3.94
B	0.205	0.213	0.22	5.21	5.4	5.59
C	0.075	0.079	0.083	1.9	2	2.1
D	0.169		0.185	4.3		4.7
F	0.006		0.012	0.152		0.305
G	-		0.008	-		0.203
H	0.085	0.091	0.096	2.15	2.3	2.45
L	0.03		0.06	0.76		1.52
X		0.11			2.8	
Y		0.079			2	
Z		0.079			2	

»Marking Information

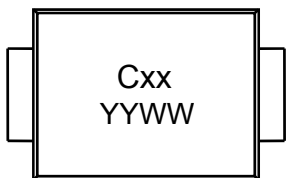

Cxx = Type Code
YYWW = Date Code

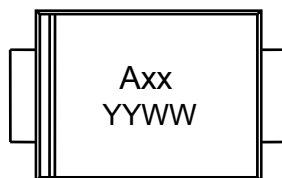

Axx = Type Code
YYWW = Date Code

»Soldering Parameters



Reflow Condition		Lead-free assembly
Pre Heat	- Temperature Min ($T_{s(min)}$)	150°C
	- Temperature Max ($T_{s(max)}$)	200°C
	- Time (min to max) (t_s)	60 – 180 secs
Average ramp up rate (Liquidus Temp (T_L) to peak)		3°C/second max
$T_{s(max)}$ to T_L - Ramp-up Rate		3°C/second max
Reflow	- Temperature (T_L) (Liquidus)	217°C
	- Time (t_L)	60 – 150 secs
Peak Temperature (T_P)		260 ^{+0/-5} °C
Time within 5°C of actual peak Temperature (t_p)		20 – 40 secs
Ramp-down Rate		6°C/second max
Time 25°C to peak Temperature (t)		8 minutes Max.
Do not exceed		260°C

»Tape and Reel Specification

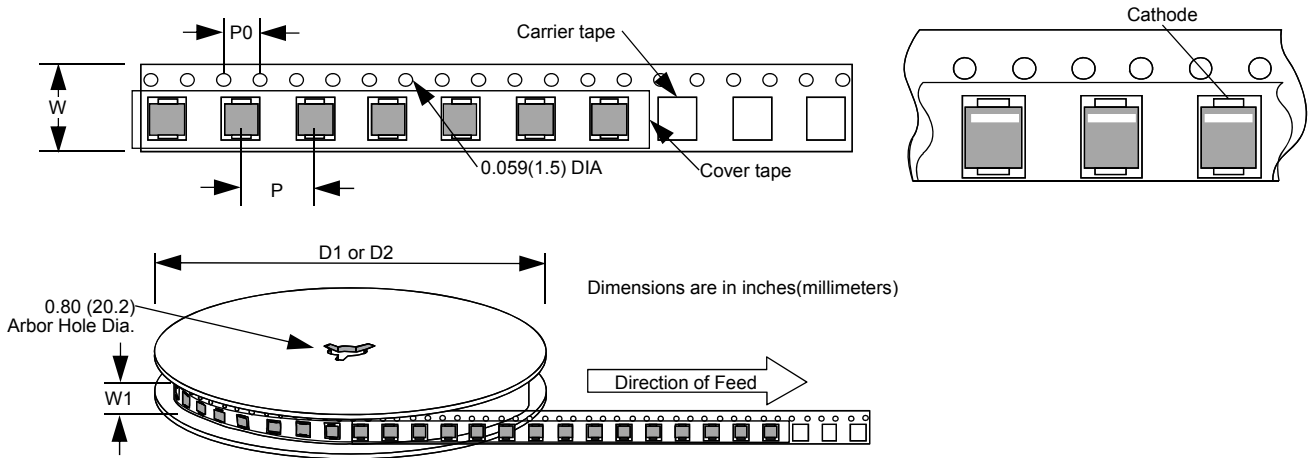

Dimension	Inches			Millimeters		
	MIN	NOM	MAX	MIN	NOM	MAX
P		0.315			8	
P0		0.157			4	
W		0.472			12	
W1		0.492			12.5	
D1		7			177.8	
D2		13			330.2	