

RoHS

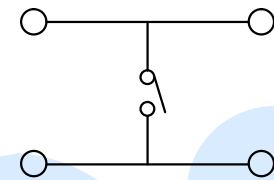

Circuit Diagram

PCB Layout(Pattern side)

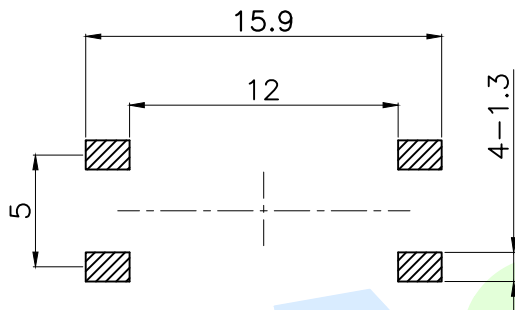
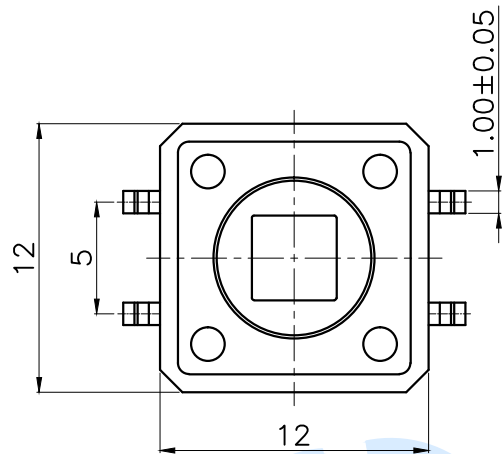
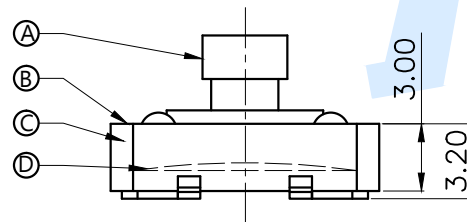
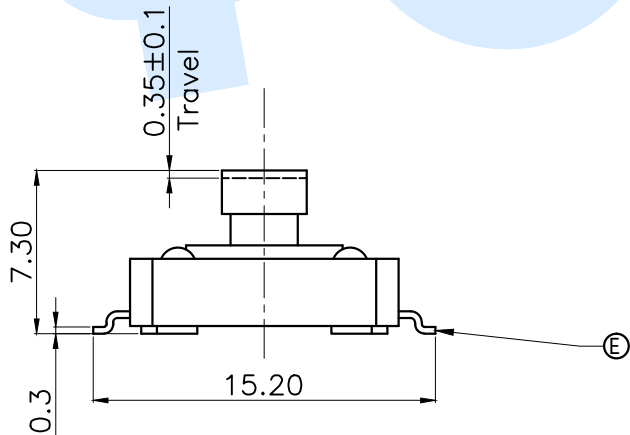

SHRAPNEL	
CODE	MATERIAL/QTY
D1	C5210/1PCS
D2	SUS/1PCS

OPERATING FORCE	
CODE	VIGOR
B1	120±30gf
B2	180±30gf
B3	250±30gf

⑤	Terminal		4	Brass	Silvering
④	Reed		1	SUS	Silver covered
③	Base		1	PPA	Black
②	Cover		1	SPCC	Plating Cu Sn
①	Button		1	PPA	Black
NO.	Name	Number	Qty	Materil	Remarks

YUANDI® Yuandi Electronics Co, Ltd

design	date	name	TACT SWITCHS
Review	date	model	TS-1094TS-B□D□
Approved	date		

Drawing number: Proportion 1:1 unit mm gage number A4

modify Review Approved Tolerance not specified

angle	±2'
10~30	±0.30
5~10	±0.20
~ 5	±0.10