

## FEATURES

- Wide Input Voltage from 2.5V to 6V
- Adjustable Output Voltage from 0.8V to VIN
- 3A Continuous Output Current
- Constant on Time (COT) Control
- Stable with low ESR Ceramic Capacitors
- 2.5MHz Switching Frequency
- 17 $\mu$ A Low Quiescent Current
- Forced Continuous Conduction Mode (FCCM) for Light Load
- 100% Duty Cycle Operation for Low Dropout
- Junction Temperature Range from  $-40^{\circ}\text{C}$  to  $125^{\circ}\text{C}$
- Internal Soft-Start
- Power Good (PG) Indicator
- Cycle-by-Cycle Current Limit Protection
- Short Circuit and Over-Load Hiccup Protection
- Thermal Shutdown Protection
- LGA-13 (2.5mm $\times$ 2.5mm $\times$ 1.24mm) Package
- Pb-Free RoHS Compliant

## APPLICATIONS

- Optical Module
- POL Power Supply
- Solid-State and Hard Disk Drives

## DESCRIPTION

The M0503 is a 3A step-down switching mode Power SoC (System on Chip) with integrated power MosFETs, inductor and input capacitors in LGA-13(2.5mm $\times$ 2.5mm $\times$ 1.24mm) package. The input voltage is from 2.5V to 6V and the switching frequency is fixed at 2.5MHz.

The M0503 provides high efficiency with COT control mode for fast transient response and good loop stability. It works on FCCM for light load and supports 100% duty cycle for low dropout.

The M0503 indicates faults by PG and provides short circuit and over-load hiccup protection and over temperature shutdown protection

## TYPICAL APPLICATION

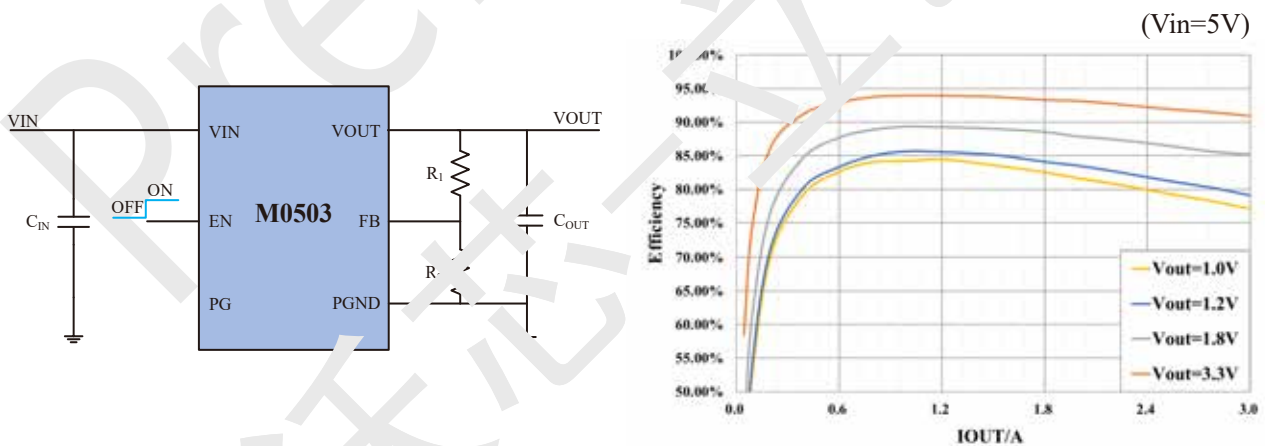

## ORDERING INFORMATION

PART NUMBER	TOP MARKING	PACKAGE	MOQ	MSL LEVEL
M0503DLBG	M0503 YWWLLL	LGA-13 (2.5mm×2.5mm×1.24mm)	3000/ Tape & Reel	3

**NOTE:** Y: Year, WW: Week, LLL: Lot Number.

## PACKAGE REFERENCE

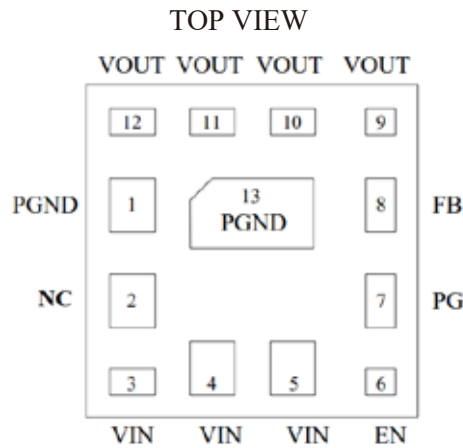

## PIN FUNCTIONS

PIN #	NAME	DESCRIPTION
1,13	PGND	<b>Power Ground.</b>
2	NC	<b>Not Connected.</b> Connect with copper pad for thermal dissipation.
3,4,5	VIN	<b>Input Voltage Power Rail.</b> VIN supplies power to all the internal control circuitry and the power switch. A decoupling capacitor to ground is recommended to be placed close to VIN directly.
6	EN	<b>Enable Control.</b> Pull this pin low puts the chip down. Pull it up high enables the chip.
7	PG	<b>Power Good.</b> The output of PG is an open drain, a pull-up resistor to power source is needed if used. If the chip works normally, PG is pulled high, else, PG is latched low.
8	FB	<b>Feedback.</b> Connect this pin with an external resistor divider from the output to GND to set the output voltage.
9,10,11,12	VOUT	<b>Output Voltage Power Rail.</b> Connect this pin with the load. Output capacitor is recommended to be placed between VOUT and PGND.

**FUNCTIONAL BLOCK DIAGRAM**

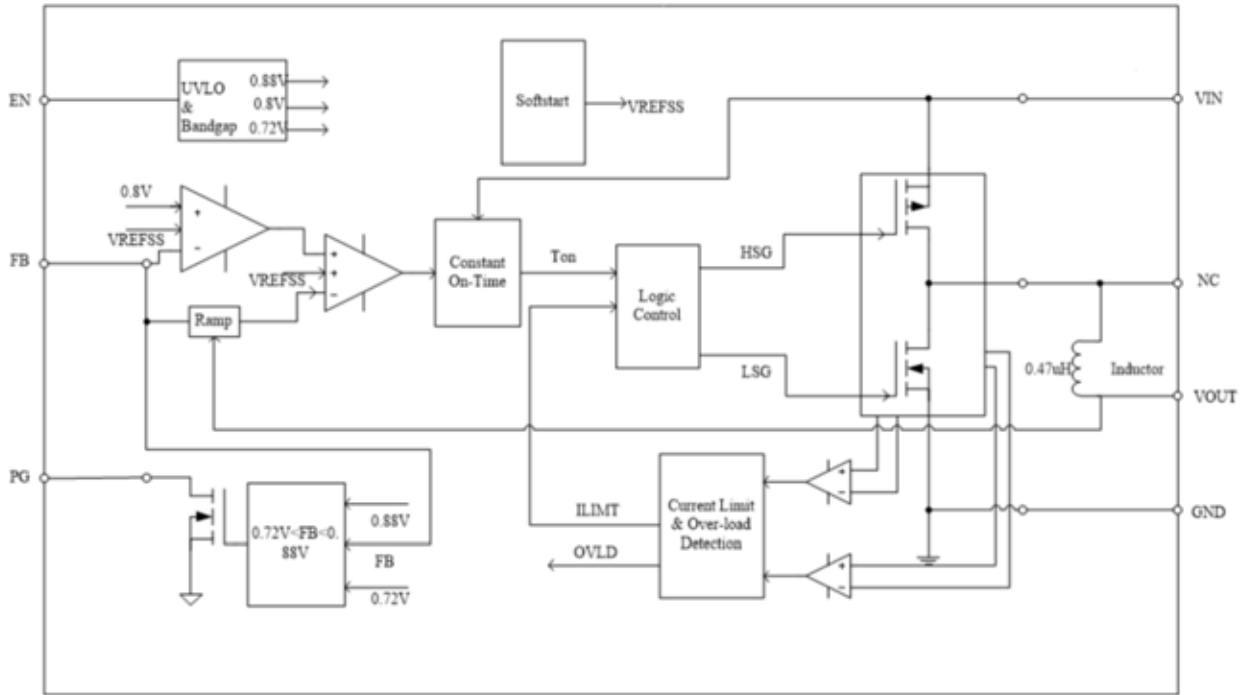

**ABSOLUTE MAXIMUM RATINGS**

	SYMBOL	MIN	MAX	UNIT
Voltage at Pins	$V_{IN}$	-0.3	6.5	V
Voltage at Other Pins		-0.3	6	V
Junction Temperature Range	$T_J$	-40	125	°C
Storage Temperature Range	$T_S$	-55	125	°C
Power Dissipation ( $T_A=+25^{\circ}\text{C}$ )	$P_D$ <sup>Note 1)</sup>		1.7	W

**RECOMMENDED OPERATING CONDITIONS**

	SYMBOL	MIN	MAX	UNIT
Input Voltage Range	$V_{IN}$	2.5	5.5	V
Output Voltage Range	$V_{OUT}$	0.8	$V_{IN}$	V
Output Current	$I_{OUT}$		3	A
Junction Temperature Range	$T_J$	-40	125	°C

**THERMAL RESISTANCE**

	SYMBOL	MIN	MAX	UNIT
Junction to Ambient	$\theta_{JA}$ <sup>Note2)</sup>		58.5	°C/W
Junction to Case	$\theta_{JC}$ <sup>Note 2)</sup>		2	°C/W

**NOTE:**

- 1) The maximum allowable continuous power dissipation at any ambient temperature ( $T_A$ ) is calculated by  $P_D(\text{max})=(T_J(\text{max}) - T_A)/\theta_{JA}$ . Exceeding the maximum allowable power dissipation will cause excessive die temperature, and the power module will go into thermal shutdown.
- 2) Measured on EVB, 2-layer PCB 1oZ.

**ELECTRICAL CHARACTERISTICS**

$V_{IN}=5V$ ,  $T_A=25^{\circ}C$ , unless otherwise noted. Typical values are at  $V_{EN}=3.6V$  and  $V_{OUT}=5V$ .

PARAMETERS	SYMBOL	CONDITION	MIN	TYP	MAX	UNIT
Input Voltage	$V_{IN}$		2.5		6.0	V
Input under Voltage Lockout Threshold	$V_{UVLO}$	$V_{IN}$ Increasing		2.4		V
Input under Voltage Lockout Hysteresis				270		mV
Input over Voltage Lockout Threshold	$V_{OVLO}$	$V_{IN}$ Increasing		6.6		V
Input over Voltage Lockout Hysteresis				410		mV
Shutdown Current	$I_{SD}$	$V_{EN}=0$ , $V_{IN}=5.5V$		0.1	5	$\mu A$
Quiescent Current (No switching)	$I_Q$	$V_{FB}=0.63V$		17		$\mu A$
EN On Threshold		$V_{EN}$ Increasing		1.21		V
EN off Threshold		$V_{EN}$ Decreasing		1.1		V
EN Internal Pull-Down Resistor				1000		k $\Omega$
Feedback Voltage	$V_{FB\_REF}$		792	800	808	mV
HS Switch Current Limit				5		A
Switching Frequency	$F_{SW}$			2.5		MHz
Soft-Start Time	$T_{SS}$			2.5		ms
PG Output Low Voltage		$V_{FB}=5V$ , sink 1mA		0.2	0.3	V
PG Under Voltage Rise Threshold		$V_{FB}$ in respect to the regulation	-12	-10	-8	%
PG Under Voltage Fall Threshold		$V_{FB}$ in respect to the regulation		-13		%
PG Delay	$T_{PG\_DELAY}$			30		$\mu s$
Thermal Shutdown				160		$^{\circ}C$
Thermal Shutdown Hysteresis				30		$^{\circ}C$

## TYPICAL PERFORMANCE CHARACTERISTICS

$V_{IN}=5V$ ,  $T_A=25^{\circ}C$ ,  $F_{SW}=2.5MHz$ ,  $V_{OUT}=1.2V$ , unless otherwise noted.

### Line Regulation

$V_{OUT}=1.2V$ ,  $I_{OUT}=3A$ ,  $V_{IN}=2.5\sim 6V$

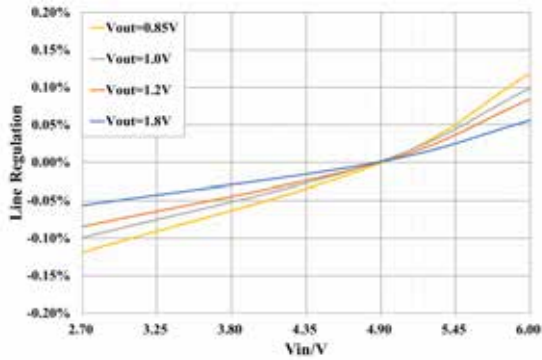

### Load Regulation

$V_{IN}=5V$ ,  $V_{OUT}=1.2V$ ,  $I_{OUT}=0\sim 3A$

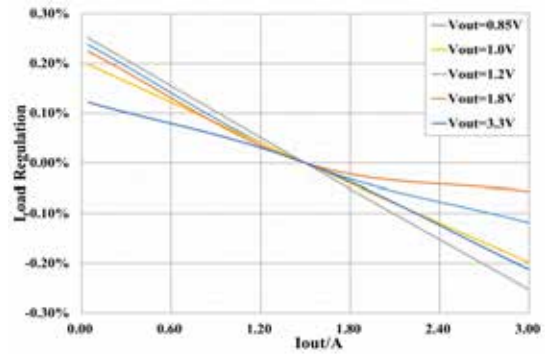

### Efficiency

$V_{IN}=5V$ ,  $V_{OUT}=1.0V/1.2V/1.8V/3.3V$ ,  $I_{OUT}=0\sim 3A$

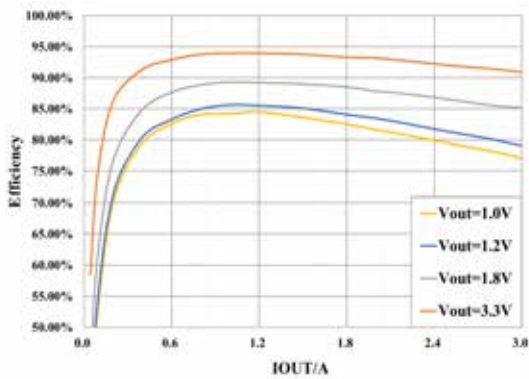

### Efficiency

$V_{IN}=3.3V$ ,  $V_{OUT}=0.85V/1.0V/1.2V/1.8V$ ,  $I_{OUT}=0\sim 3A$

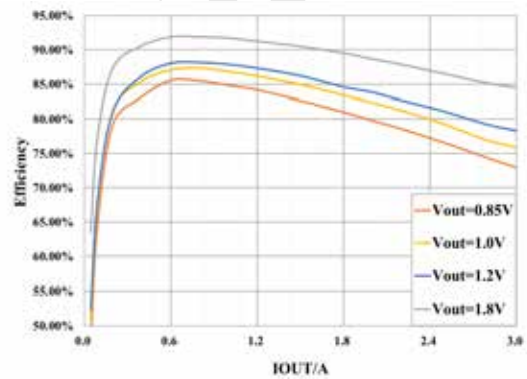

### Thermal Derating

$V_{IN} = 5V$ ,  $V_{OUT}=0.85V/1.0V/1.2V/1.8V/3.3V$

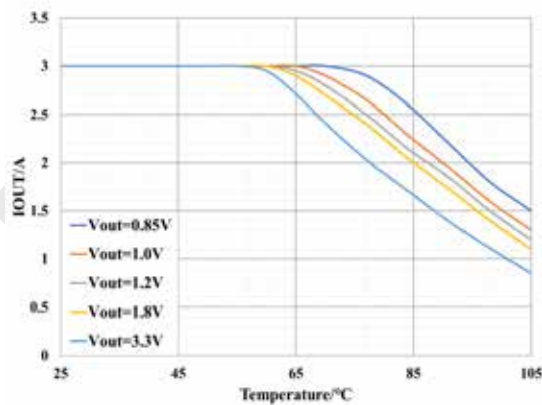

**TYPICAL PERFORMANCE CHARACTERISTICS (continued)**

$V_{IN}=5V$ ,  $T_A=25^{\circ}C$ ,  $F_{SW}=2.5MHz$ ,  $V_{OUT}=1.2V$ , unless otherwise noted.

**VIN Start up**

$I_{OUT}=0A$

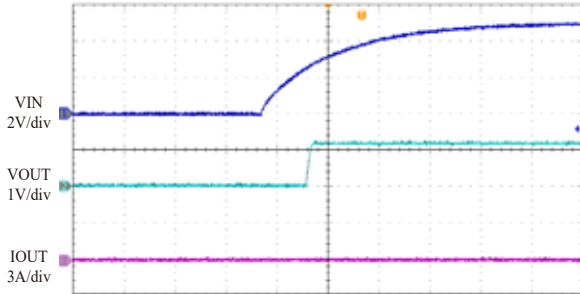

20ms/div

**VIN Start up**

$I_{OUT}=3A$

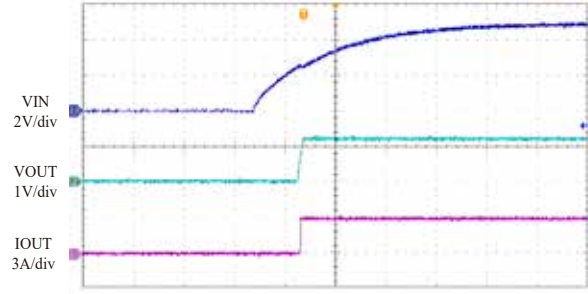

20ms/div

**VIN Shut down**

$I_{OUT}=0A$

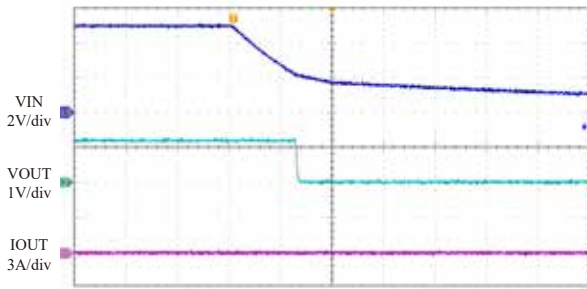

20ms/div

**VIN Shut down**

$I_{OUT}=3A$

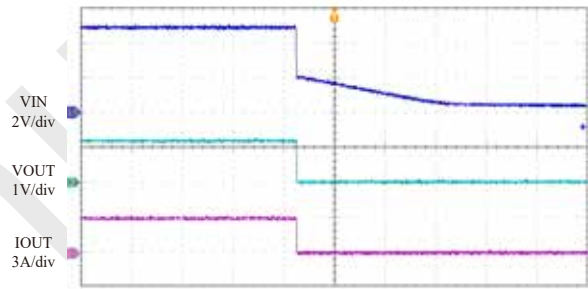

20ms/div

**EN Start up**

$I_{OUT}=0A$

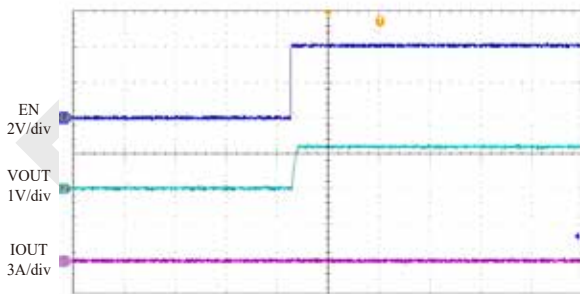

20ms/div

**EN Start up**

$I_{OUT}=3A$

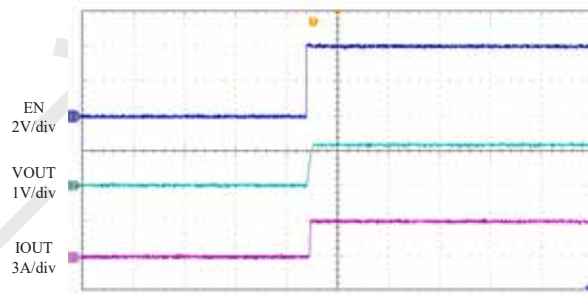

20ms/div



**TYPICAL PERFORMANCE CHARACTERISTICS (continued)**

$V_{IN}=5V$ ,  $T_A=25^{\circ}C$ ,  $F_{SW}=2.5MHz$ ,  $V_{OUT}=1.2V$ , unless otherwise noted.

**EN Shut down**  
 $I_{OUT}=0A$

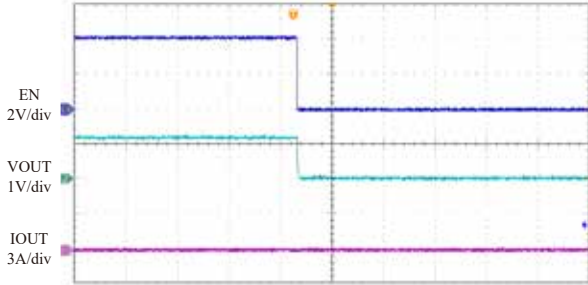

20ms/div

**EN Shut down**  
 $I_{OUT}=3A$

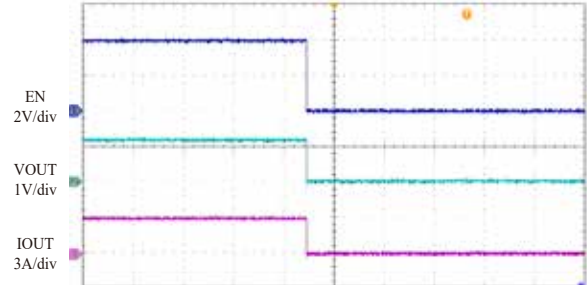

20ms/div

**SCP Enter**  
 $I_{OUT}=0A$

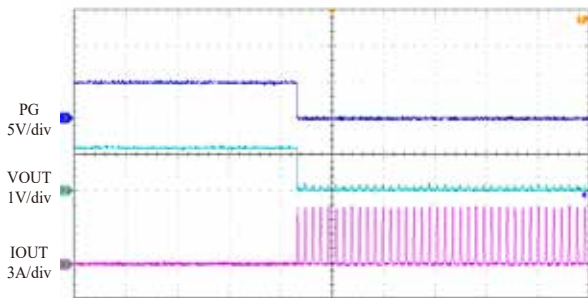

10ms/div

**SCP Enter**  
 $I_{OUT}=3A$

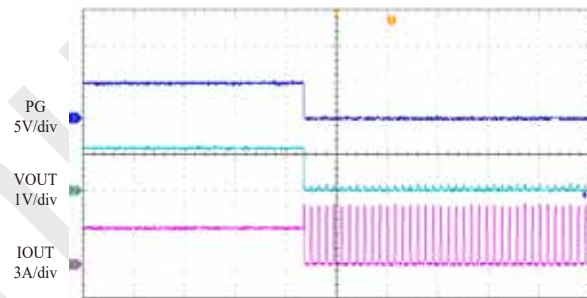

10ms/div

**SCP Recover**  
 $I_{OUT}=0A$

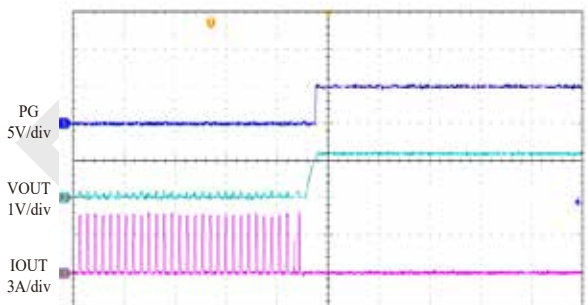

10ms/div

**SCP Recover**  
 $I_{OUT}=3A$

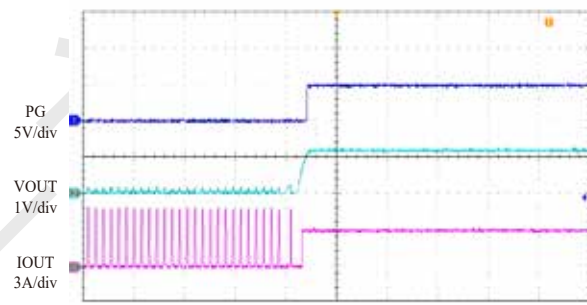

10ms/div



**TYPICAL PERFORMANCE CHARACTERISTICS (continued)**

$V_{IN}=5V$ ,  $T_A=25^{\circ}C$ ,  $F_{SW}=2.5MHz$ ,  $V_{OUT}=1.2V$ , unless otherwise noted.

**VOUT Ripple**

$I_{OUT}=0A$

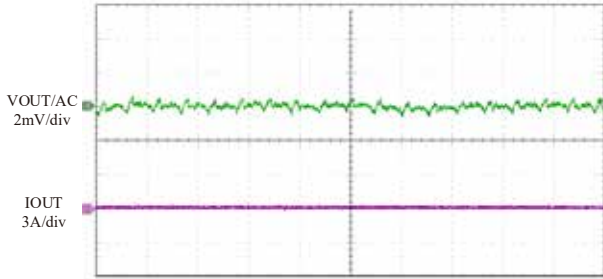

800ns/div

**VOUT Ripple**

$I_{OUT}=3A$

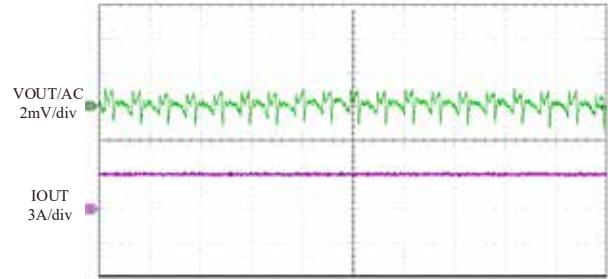

800ns/div

**Load Transient**

$I_{OUT}=0A$  to 1.5A, 1A/ $\mu s$

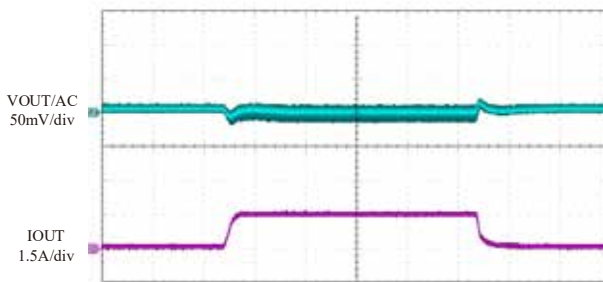

100us/div

**Load Transient**

$I_{OUT}=0A$  to 3A, 1A/ $\mu s$

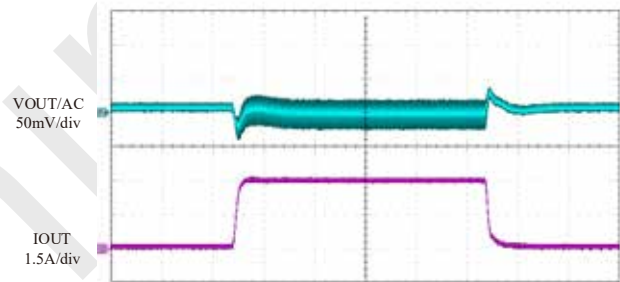

100us/div

**Load Transient**

$I_{OUT}=1.5A$  to 3A, 1A/ $\mu s$

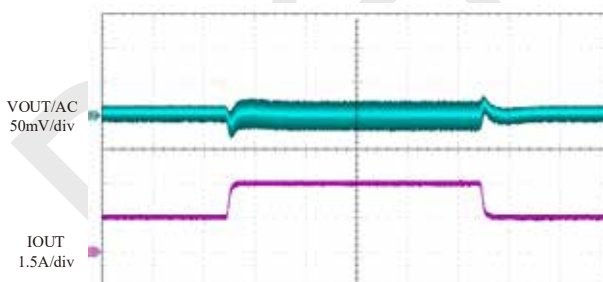

100us/div

## OPERATION

The M0503 is a 3A synchronous step-down switching mode Power SoC with integrated high-side and low-side power MosFETs, inductor and input decoupling capacitor in LGA-13 (2.5mm×2.5mm×1.24mm) package. Only FB resistor divider, input and output capacitors are needed to complete the design over 2.5V to 6V input voltage range. The M0503 supports output voltage of 0.8V to 6V with the fixed switching frequency of 2.5MHz.

M0503 works on COT control mode that offers excellent transient response over the wide range of input voltage. M0503 operates in Forced Continuous Conduction Mode (FCCM) in light load condition which achieves low ripples. M0503 can work on 100% duty cycle when the dropout between input and output is low. The soft start time of M0503 is 2.5ms internally. Fully integrated protection features include OCP, UVP, OTP and all these faults can be indicated by PG. The

protection function details are shown below.

### OVER CURRENT PROTECTION (OCP)

M0503 has a typical 5A cycle-by-cycle High-Side current limit protection to prevent inductor current from running away. When the High-Side switch reaches the current limit, M0503 will enter hiccup mode. It will stop switching for a pre-determined period of time and automatically start up again. It always starts up with soft-start to limit inrush current and avoid output overshoot.

### OVER TEMPERATURE PROTECTION (OTP)

M0503 will stop switching when the junction temperature exceeds 160 °C. The device will power up again when the junction temperature drops below 130°C.

## APPLICATION INFORMATION

### Setting the Output Voltage

The output voltage is set by the external feedback resistor divider as the typical application circuit on Page 1. The bottom feedback resistor  $R_2$  can impact the loop stability. For any chosen  $R_2$ , the top feedback resistor  $R_1$  can be calculated as:

$$R_1 = R_2 \cdot \left( \frac{V_{OUT}}{V_{FB}} - 1 \right)$$

Table 1 lists the recommended feedback resistor values for common output voltages.

**Table 1: FB Resistor Values for Common Output Voltages.**

$V_{OUT}(V)$	$R_1(k\Omega)$	$R_2(k\Omega)$
3.3	100	31.6
1.8	37.4	30
1.2	15	30
1.0	7.5	30

### Input Capacitor Selection

The input current of the step-down converter is discontinuous with sharp edges, therefore, placing input filter capacitors is necessary. For better performance, low ESR ceramic capacitor with X5R or X7R dielectrics are highly recommended because of their lowest temperature variations. The RMS current of the input capacitor is calculated:

$$I_{CIN\_RMS} = I_{OUT} \sqrt{D(1-D)}$$

in which D is the Duty Cycle and when the current is continuous,  $D = V_{OUT}/V_{IN}$ ;  $I_{OUT}$  is the output load current. As the equation above, when D is 0.5, the highest RMS current is approximately:

$$I_{CIN\_RMS} = \frac{1}{2} \times I_{OUT}$$

So, it is recommended to choose the capacitors with the RMS current rating higher than  $1/2 I_{OUT}$ .

The power dissipation on the input capacitors can be estimated with the RMS current and the ESR resistor.

Electrolytic or tantalum capacitors can also be used. The input voltage ripple caused by the capacitor can be calculated as:

$$\Delta V_{CIN} = \frac{I_{OUT}}{F_{SW} \cdot C_{IN}} \cdot \frac{V_{OUT}}{V_{IN}} \cdot \left( 1 - \frac{V_{OUT}}{V_{IN}} \right)$$

in which,  $F_{SW}$  is switching frequency of 2.5MHz.

### Output Capacitor Selection

Output capacitors are required to keep stable output voltage. To minimize the output voltage ripple, low ESR ceramic capacitors should be used. The output voltage ripple can be estimated as:

$$\Delta V_{OUT} = \frac{V_{OUT}}{8F_{SW}^2 C_{OUT} L} \cdot \left( 1 - \frac{V_{OUT}}{V_{IN}} \right)$$

In which, L is the inductor, which value is fixed at 0.47 $\mu$ H internally.

If electrolytic or tantalum capacitor are used, the ESR will dominate the output voltage ripple as:

$$\Delta V_{OUT} = R_{ESR} \cdot \frac{V_{OUT}}{F_{SW} L} \cdot \left( 1 - \frac{V_{OUT}}{V_{IN}} \right)$$

### Enable Control

When input voltage is above the under-voltage-lock-out threshold, M0503 can be enabled by pulling the EN pin to above 1.21V and will be disabled if the EN pin is below 1.1V. It is recommended to pull up to  $V_{IN}$  with the resistor about 100k $\Omega$ .

### Power Good Indicator

M0503 has an open drain PG indicator. PG will be pulled up if output voltage is within  $\pm 10\%$  of regulation, otherwise PG is pulled down by internal NMOS. A pull-up resistor to  $V_{IN}$  or  $V_{OUT}$  is needed if used and it is recommended to choose the resistor about 100k $\Omega$ .

### PCB Layout Guide

To optimize the electrical and thermal performance, some PCB layout guidelines should be considered as below:

1. Use wide trace for the high current paths and keep it as short as possible. It helps to minimize the PCB conduction loss and thermal stress.
2. Place the input coupling capacitor close to  $V_{IN}$  and PGND.
3. Connect all feedback network to FB shortly.
4. Keep the FB network away from the SW.

**6V Input, 3A Step Down DC-DC Power SoC with Integrated Inductor**

- The PGND should be connected to a strong ground plane for better heat dissipation and noise protection.

Figure 1 gives a good example of the recommended layout.

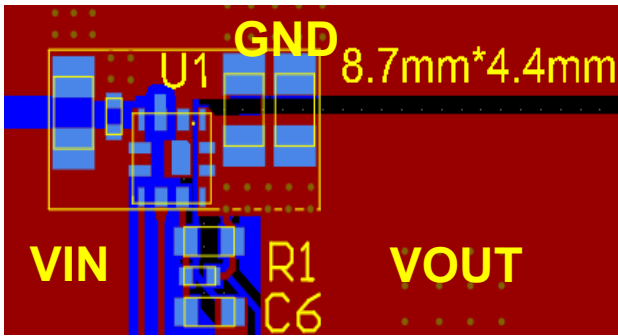

(a) Top Layer

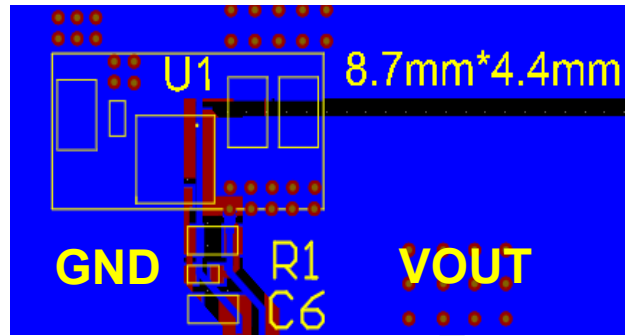

(b) Bottom Layer

Figure 1. Recommended Layout

## TYPICAL APPLICATION

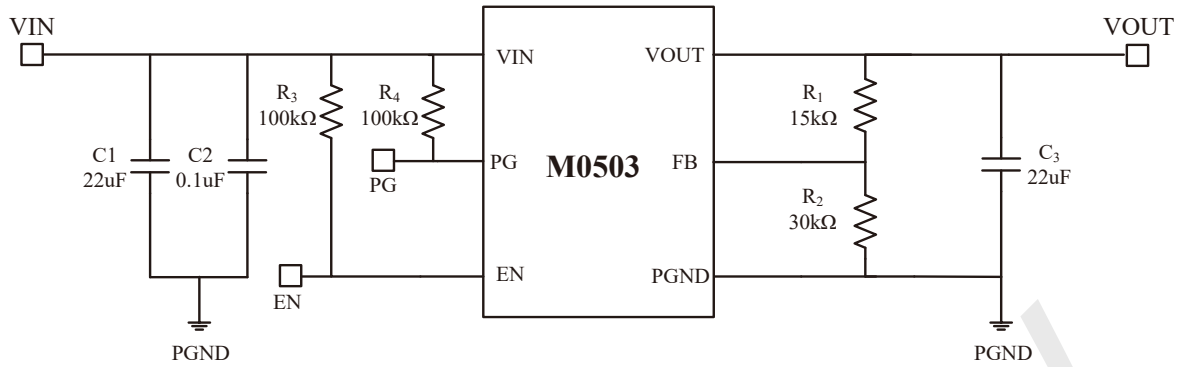

Figure 2. Typical Application Circuits of M0503 for 1.2V@3A Output

Table 2: Reference Design

VOUT(V)	CIN(µF)	COUT(µF)	R <sub>1</sub> (kΩ)	R <sub>2</sub> (kΩ)
3.3V	2×22	3×22	100	31.6
1.8V	22	3×22	37.4	30
1.2V	22	2×22	15	30
1.0V	22	2×22	7.5	30

### NOTE:

CIN is the sum of the input capacitors, COUT is the sum of the output capacitors, please refer to Figure 2 for parameters of other components.

**PACKAGE INFORMATION**

LGA-13(2.5mm×2.5mm×1.24mm) Package

TOP VIEW

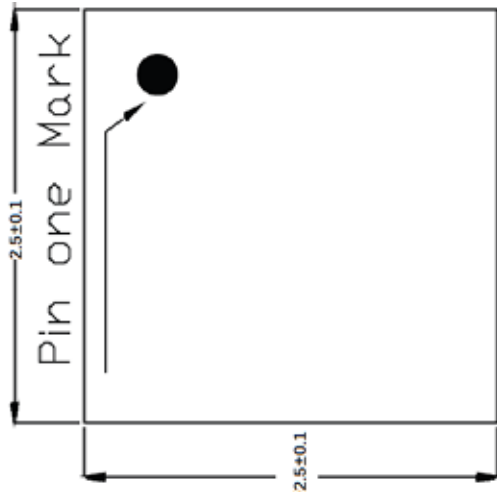

SIDE VIEW

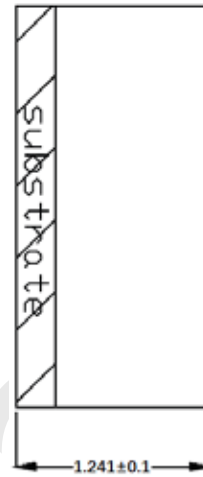

BOTTOM VIEW

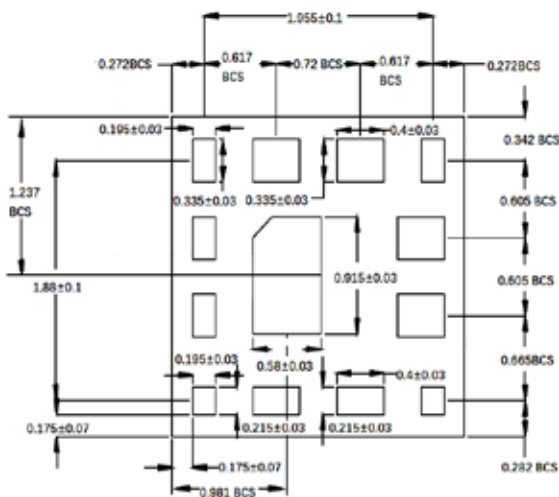

RECOMMENDED LAND PATTERN

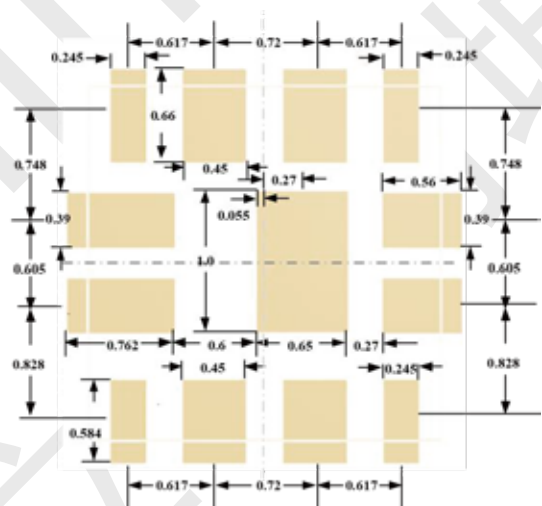

**NOTES**

All dimensions are in MM.

**CARRIER INFORMATION**

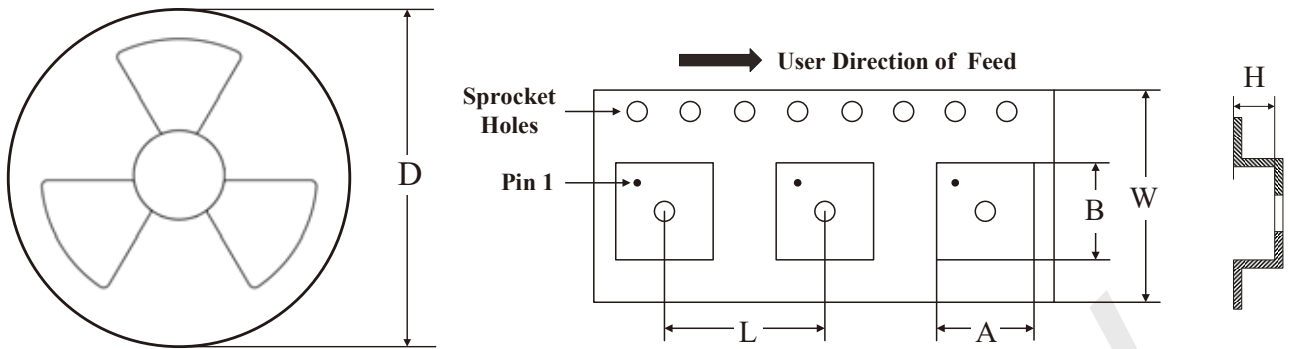

Part Number	Package	Quantity /Reel	D	A	B	L	W	H
M0503DLBG	LGA-13 (2.5mm×2.5mm×1.24mm)	3000	13 in	2.7mm	2.7mm	8mm	12mm	1.5mm