

## FEATURES

- Wide Input Voltage from 2.4V to 16V
  - ◇ 2.4V to 16V with External 3.3V VCC Bias
  - ◇ 3.5V to 16V with Internal VCC Bias or External 3.3V VCC Bias
- Adjustable Output Voltage from 0.6V to 5.5V, and 90% Max Duty Cycle
- 15A Continuous, 20A Peak Output Current
- Constant On Time (COT) Control
- Stable with low ESR Ceramic Capacitors
- Selectable Switching Frequency from 600kHz, 800kHz and 1MHz
- Selectable Power Save Mode (PSM) or Forced Continuous Conduction Mode (FCCM) for Light Load
- Pre-Biased Start-Up
- Differential Output Voltage Sense
- Output Voltage Discharge
- Power Good Indicator
- Junction Temperature Range from  $-40^{\circ}\text{C}$  to  $125^{\circ}\text{C}$
- Programmable Soft-Start Time
- Programmable Output Current Limit
- Cycle-by-Cycle Output Current Limit
- Hiccup Mode for Short Circuit and Over-Load Protection
- Thermal Shutdown Protection
- Over Voltage Protection
- QFN-29 (7.0mm $\times$ 7.0mm $\times$ 3.95mm) Package
- Pb-Free RoHS Compliant

## DESCRIPTION

The M1220 is a 15A Continuous, 20A Peak step-down switching mode Power SoC (System on Chip) with integrated controller, power MOSFETs, inductor and input decoupling capacitor in QFN-29 package. The input voltage is from 2.4V to 16V and the output voltage is adjustable from 0.6V to 5.5V. The M1220 also has flexible programmable functions such as the soft-start time and output current limit. And the switching frequency is selectable from 600kHz, 800kHz and 1MHz.

The M1220 provides high efficiency with Constant On Time (COT) control mode for fast transient response and good loop stability. It can work on selectable Power Save Mode (PSM) or Forced Continuous Conduction Mode (FCCM) for light load with excellent load regulation and line regulation.

The M1220 can also indicate faults and provide overload and short circuit hiccup protection, under voltage and over voltage protection, and over temperature shutdown protection.

## APPLICATIONS

- Telecom Systems
- Servers & Data Centers
- FPGA & ASIC Cards
- Industry Systems

## TYPICAL APPLICATION

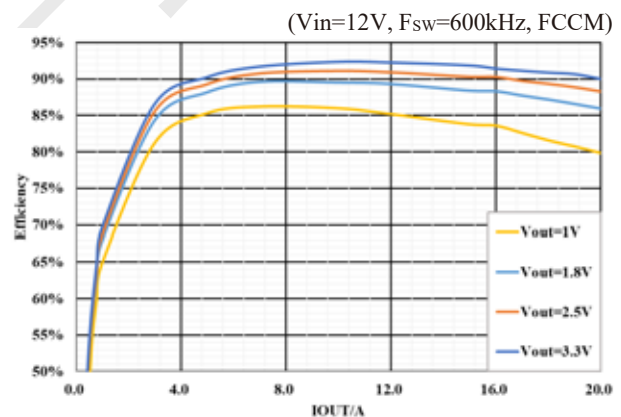
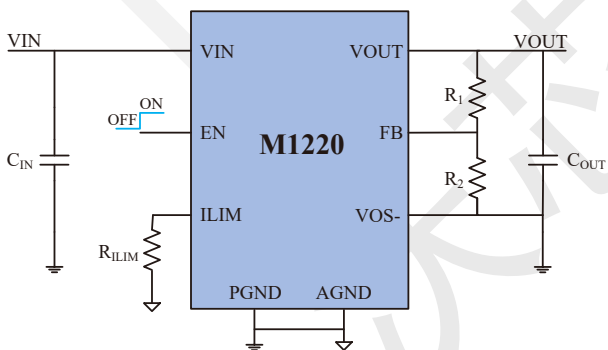

## ORDERING INFORMATION

PART NUMBER	TOP MARKING	PACKAGE	MOQ	MSL LEVEL
M1220DQEE	M1220 YWWLLL	QFN-29 (7.0mm×7.0mm×3.95mm)	1000/ Tape & Reel	3

**NOTE:** Y: Year, WW: Week, LLL: Lot Number.

## PACKAGE REFERENCE

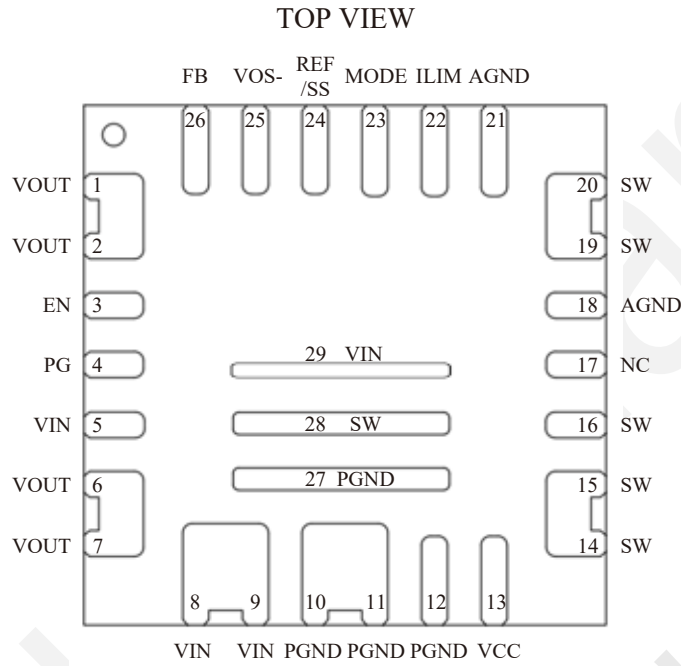

**PIN FUNCTIONS**

PIN #	NAME	DESCRIPTION
1,2,6,7	VOUT	<b>Output Voltage Power Rail.</b> Connect this pin with the load. Output capacitor is recommended to be placed between VOUT and PGND
3	EN	<b>Enable Control.</b> Pulling this pin low can shut the chip. Pulling it up can enable the chip.
4	PG	<b>Power Good.</b> The output of PG is an open drain, a pull-up resistor to power source is needed if used. If the chip works normally, PG is pulled high, else, PG is latched low.
5,8,9,29	VIN	<b>Input Voltage Power Rail.</b>
10,11,12,27	PGND	<b>Power Ground.</b>
13	VCC	<b>Not Connected. Internal 4.8V LDO Output.</b> An output capacitor to ground have been placed internally.
14,15,16,19,20,28	SW	<b>Not Connected. Internal SW Pad.</b> Connect with copper pad for thermal dissipation.
17	NC	<b>Not Connected. Internal Bootstrap Pad.</b> A Bootstrap capacitor to SW has been placed internally.
18,21	AGND	<b>Analog Ground.</b>
22	ILIM	<b>Output Current Limit.</b> Connect a resistor to AGND to program the current limit.
23	MODE	<b>Operation Mode Selection.</b> Connect a resistor to AGND to program the operation mode and the switching frequency. This pin is floating for PSM and 800KHz as the default status.
24	REF/SS	<b>Output Voltage Tracking Reference/Soft Start.</b> The output voltage tracks this input signal. A decoupling ceramic capacitor recommended to be placed close to this pin. The capacitance determines the soft-start time.
25	VOS-	<b>VOUT Sense-.</b> Connect to the negative side of the voltage sense point directly. Connect to AGND if not used.
26	FB	<b>Feedback (VOUT Sense+).</b> Connect this pin with an external resistor divider from the output to VOS- and keep them as close as possible to the pin.

### Functional Block Diagram

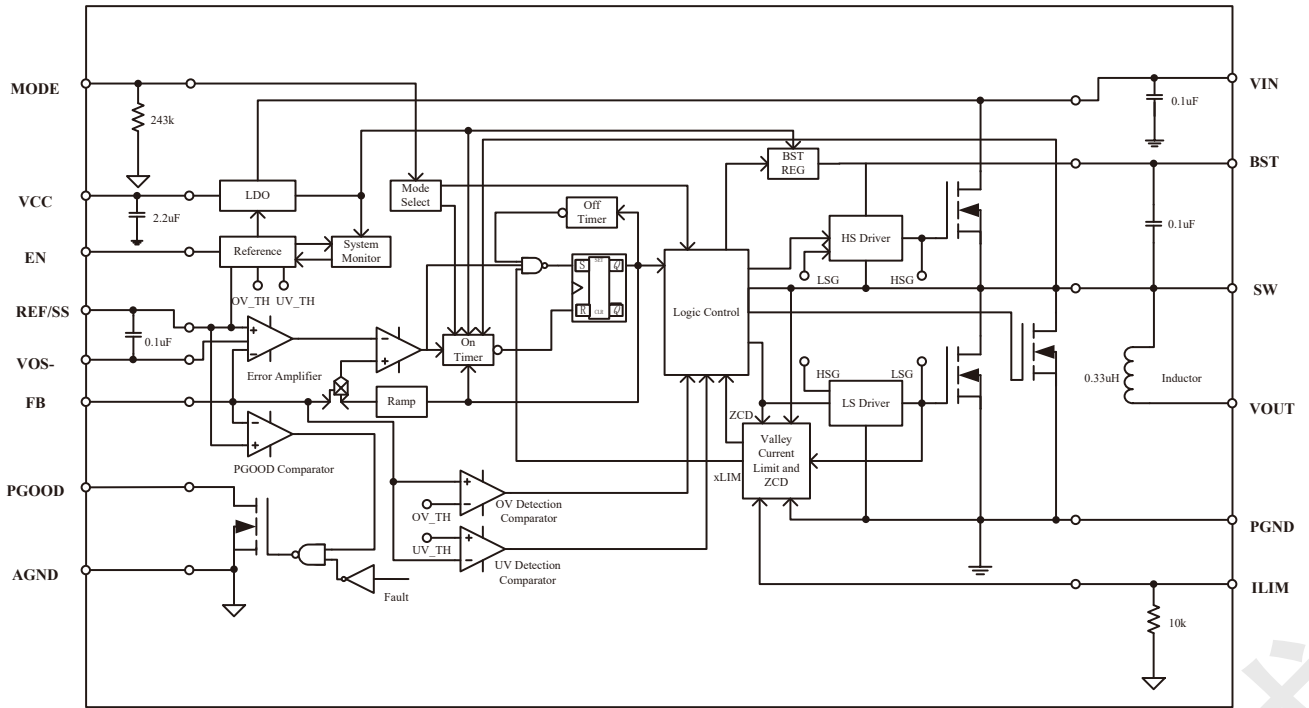

**ABSOLUTE MAXIMUM RATINGS**

	SYMBOL	MIN	MAX	UNIT
Voltage at V <sub>IN</sub> Pins	V <sub>IN</sub>	-0.3	20	V
Voltage at SW Pins	V <sub>SW(DC)</sub>	-0.3	20	V
Voltage at SW Pins	V <sub>SW(25ns)</sub>	-5	25	V
Voltage at VCC Pins	VCC	-0.3	5.5	V
Voltage at Other Pins		-0.3	5.5	V
Junction Temperature Range	T <sub>J</sub>	-40	125	°C
Storage Temperature Range	T <sub>S</sub>	-65	150	°C
Power Dissipation (T <sub>A</sub> =+25°C)	P <sub>D</sub> <sup>Note 1)</sup>		5.8	W

**ESD Ratings**

Electrostatic Discharge	STANDARD	VALUE
Human Body Mode(HBM)	JEDEC EIA/JESD22-A114	1500V
Charge Device Mode(CDM)	JEDEC EIA/JESD22-C101F	2000V

**RECOMMENDED OPERATING CONDITIONS**

	SYMBOL	MIN	MAX	UNIT
Input Voltage Range	V <sub>IN</sub>	2.4	16	V
Output Voltage Range	V <sub>OUT</sub>	0.6	5.5	V
Output Current Range	I <sub>OUT</sub>		20	A
EN Voltage Range	V <sub>EN</sub>		4.5	V
Junction Temperature Range	T <sub>J</sub>	-40	125	°C

**THERMAL RESISTANCE**

	SYMBOL	MIN	MAX	UNIT
Junction to Ambient	θ <sub>JA</sub> <sup>Note 2)</sup>		17	°C/W
Junction to Case	θ <sub>JC</sub> <sup>Note 2)</sup>		1	°C/W

**NOTES:**

- 1) The maximum allowable continuous power dissipation at any ambient temperature (T<sub>A</sub>) is calculated by P<sub>D(max)</sub>=(T<sub>J(max)</sub> - T<sub>A</sub>)/θ<sub>JA</sub>. Exceeding the maximum allowable power dissipation will cause excessive die temperature, and the power module will go into thermal shutdown.
- 2) Measured on EVB, 6-layer PCB 2oz.

## ELECTRICAL CHARACTERISTICS

$V_{IN}=12V$ ,  $T_A=25^{\circ}C$ , unless otherwise noted.

PARAMETERS	SYMBOL	CONDITION	MIN	TYP	MAX	UNIT
Input Voltage	$V_{IN}$	with Internal LDO	3.5		16	V
Input Voltage	$V_{IN}$	with External VCC Bias	2.4		16	V
VIN Hysteresis			500	600	700	mV
Shutdown Current	$I_{SD}$	$V_{EN}=0$		7	10	$\mu A$
Quiescent Current (No Switching)	$I_{Q1}$	$V_{EN}=2V$ , $V_{FB}=1V$	1000	1950	2000	$\mu A$
Quiescent Current (No Load)	$I_{Q2}$	$V_{IN}=12V$ , $V_{OUT}=1.2V$ , PSM			2	mA
EN On Threshold	$V_{EN\_R}$	$V_{EN}$ Rising	1.0	1.22	1.4	V
EN Hysteresis			150	200	250	mV
Soft Discharge FET Resistance	$R_{ON\_DIS}$		150	180	200	$\Omega$
VCC under Voltage Lockout rising Threshold	$V_{CCUVLO\_R}$	$V_{CC}$ Rising	2.5	3.0	3.5	V
VCC Hysteresis			0.2	0.3	0.5	V
VCC Regulator	VCC	$5.3V < V_{IN} < 16V$	4.5	4.8	5.1	V
VCC Output Current Limit			25			mA
VCC Load Regulation		$I_{VCC}=25mA$			2.2	%
Feedback Voltage	$V_{FB\_REF}$		594	600	606	mV
Current Limit	$V_{ILIM}$		0.9	1.2	1.5	V
$I_{LIM}$ to $I_{OUT}$ Ratio	$I_{LIM}/I_{OUT}$		9.5	10	11	$\mu A/A$
LS Negative Current Limit			-8	-10	-13	A
Switching Frequency	$F_{SW}$	MODE=GND/VCC	500	600	700	kHz
		MODE=Float/34.8k $\Omega$	700	800	900	kHz
		MODE=243k $\Omega$ /80.6k $\Omega$	900	1000	1100	kHz
Soft-Start Time	$T_{SS}$	$C_{REF}=1nF$	1.2	1.5	1.8	ms
REF/SS sourcing current	$I_{REF\_SO}$		32	36	52	$\mu A$
REF/SS sinking current	$I_{REF\_SI}$		9	12	20	$\mu A$
PG Low Trip Threshold	$V_{PGL\_R}$	$V_{PG}$ Rising, $V_{FB}$ in respect to $V_{FB\_REF}$	85	92.5	95	%
	$V_{PGL\_F}$	$V_{PG}$ Falling, $V_{FB}$ in respect to $V_{FB\_REF}$	65	70	75	%
PG High Trip Threshold	$V_{PGH\_R}$	$V_{PG}$ Rising, $V_{FB}$ in respect to $V_{FB\_REF}$	112	116	120	%

**ELECTRICAL CHARACTERISTICS (continued)**

$V_{IN}=12V$ ,  $T_A=25^{\circ}C$ , unless otherwise noted.

PARAMETERS	SYMBOL	CONDITION	MIN	TYP	MAX	UNIT
Over Voltage Protection	$V_{OVP}$	$V_{FB}$ in respect to $V_{FB\_REF}$	113	116	119	%
		LS OFF Threshold		50		%
Under Voltage Protection	$V_{UVP}$	$V_{FB}$ in respect to $V_{FB\_REF}$	77	80	83	%
Thermal Shutdown				160		$^{\circ}C$
Thermal Shutdown Hysteresis				30		$^{\circ}C$

## TYPICAL PERFORMANCE CHARACTERISTICS

$V_{IN}=12V$ ,  $T_A=25^{\circ}C$ , FCCM,  $F_{SW}=600kHz$ ,  $V_{OUT}=1.2V$ , unless otherwise noted.

### Line Regulation

$V_{OUT}=1V/1.2V/1.8V/2.5V/3.3V$ ,  $I_{OUT}=15A$ ,  
 $V_{IN}=3.5\sim 16V$

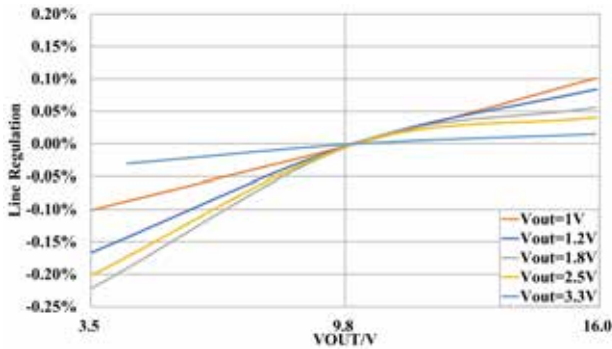

### Load Regulation

$V_{IN}=12V$ ,  $V_{OUT}=1V/1.2V/1.8V/2.5V/3.3V$ ,  
 $I_{OUT}=0\sim 20A$

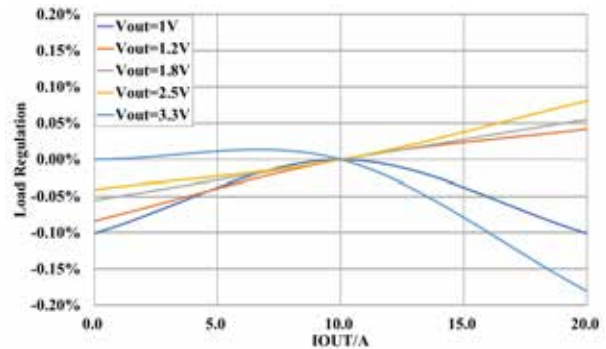

### Efficiency

$V_{IN}=12V$ ,  $V_{OUT}=1V/1.8V/2.5V/3.3V$ ,  $I_{OUT}=0\sim 20A$

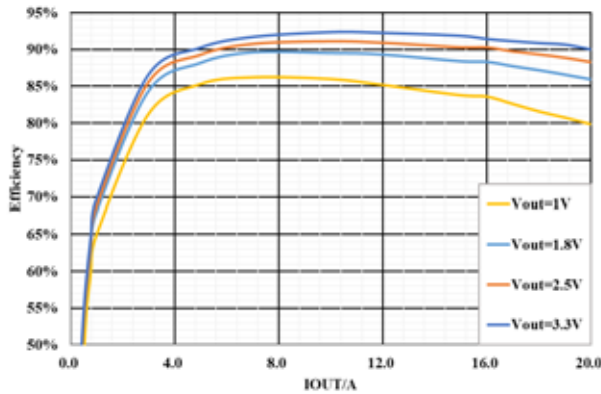

### Efficiency

$V_{IN}=5V$ ,  $V_{OUT}=1V/1.2V/1.8V/2.5V$ ,  $I_{OUT}=0\sim 20A$

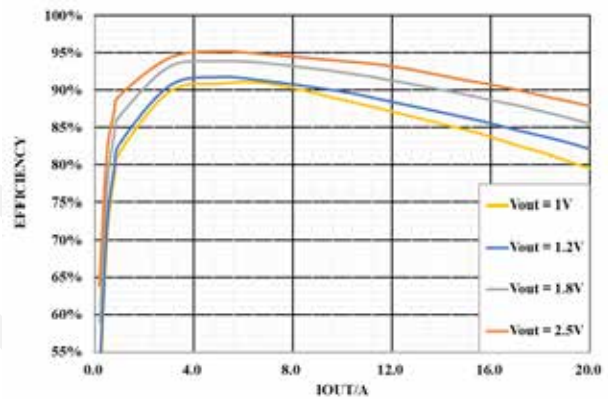

### Thermal Derating

$V_{IN} = 12V$ ,  $V_{OUT}=0.85V/1V/1.2V/1.8V/2.5V/3.3V$

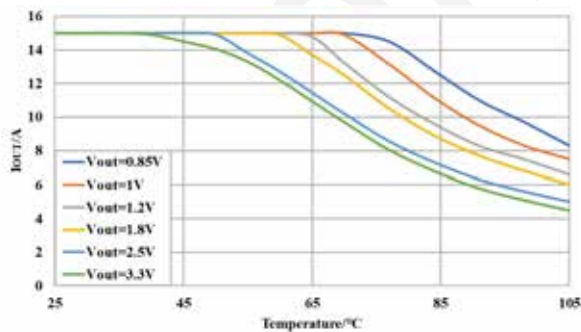



**TYPICAL PERFORMANCE CHARACTERISTICS (continued)**

$V_{IN}=12V$ ,  $T_A=25^{\circ}C$ , FCCM,  $F_{sw}=600kHz$ ,  $V_{OUT}=1.2V$ , unless otherwise noted.

**VIN Start up**  
 $I_{OUT}=0A$

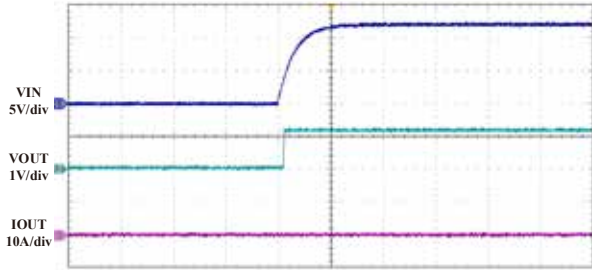

100ms/div

**VIN Start up**  
 $I_{OUT}=20A$

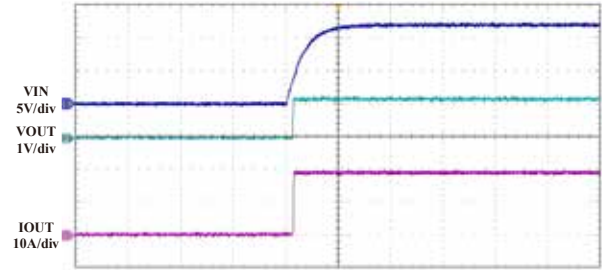

100ms/div

**VIN Shut down**  
 $I_{OUT}=0A$

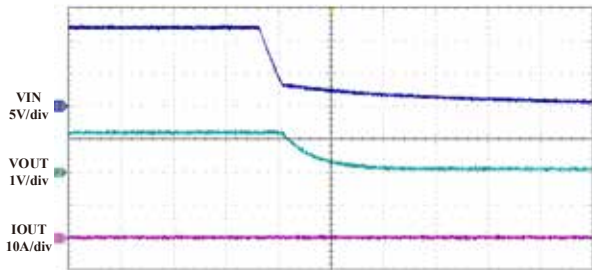

100ms/div

**VIN Shut down**  
 $I_{OUT}=20A$

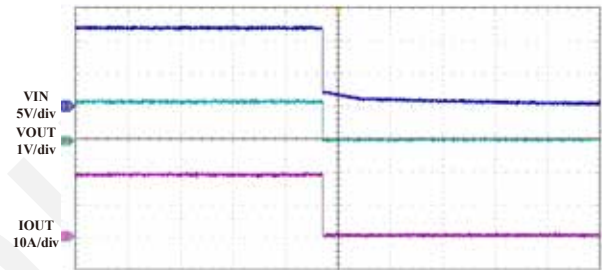

100ms/div

**EN Start up**  
 $I_{OUT}=0A$

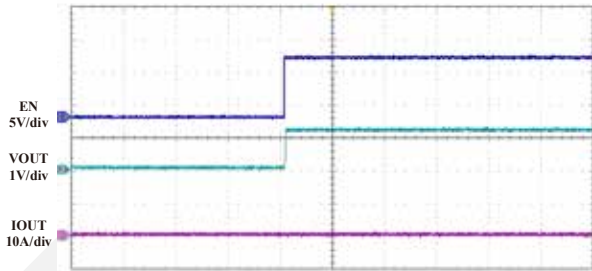

100ms/div

**EN Start up**  
 $I_{OUT}=20A$

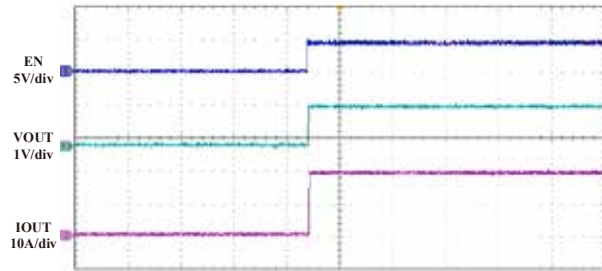

100ms/div

**EN Shut down**  
 $I_{OUT}=0A$

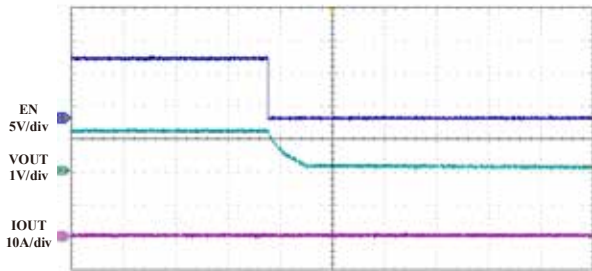

100ms/div

**EN Shut down**  
 $I_{OUT}=20A$

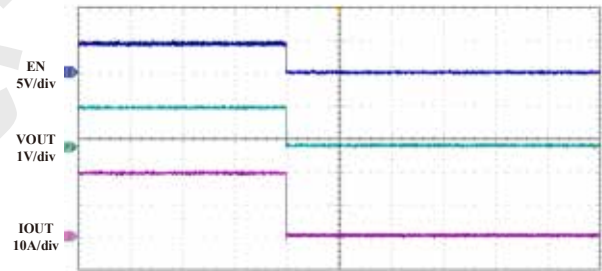

100ms/div

**TYPICAL PERFORMANCE CHARACTERISTICS (continued)**

$V_{IN}=12V$ ,  $T_A=25^{\circ}C$ , FCCM,  $F_{SW}=600kHz$ ,  $V_{OUT}=1.2V$ , unless otherwise noted.

**SCP Enter**  
 $I_{OUT}=0A$

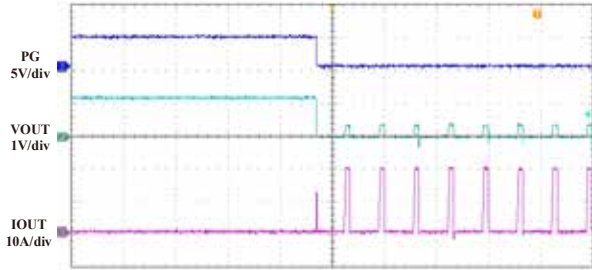

20ms/div

**SCP Enter**  
 $I_{OUT}=20A$

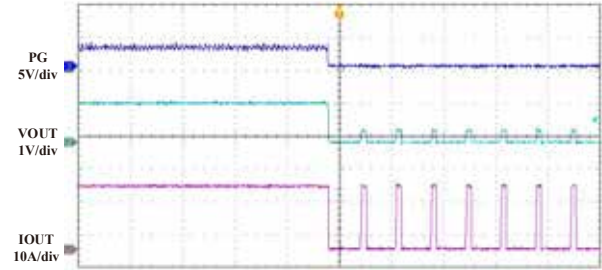

20ms/div

**SCP Recover**  
 $I_{OUT}=0A$

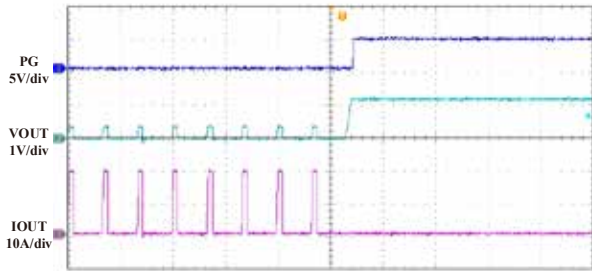

20ms/div

**SCP Recover**  
 $I_{OUT}=20A$

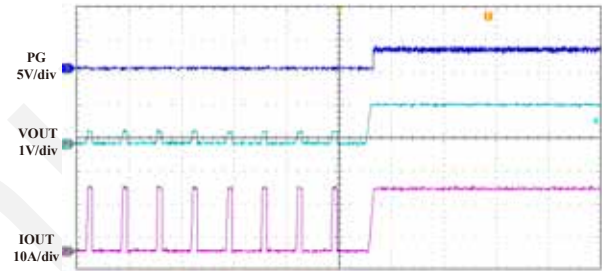

20ms/div

**VOUT Ripple**  
 $I_{OUT}=0A$

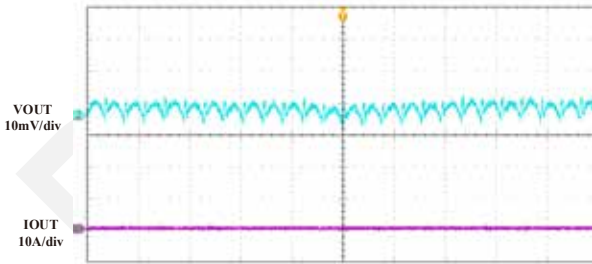

4us/div

**VOUT Ripple**  
 $I_{OUT}=20A$

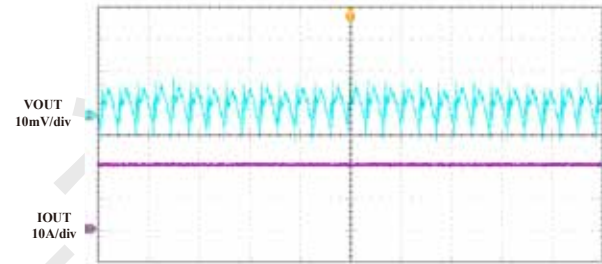

4us/div

**TYPICAL PERFORMANCE CHARACTERISTICS (continued)**

$V_{IN}=12V$ ,  $T_A=25^{\circ}C$ , FCCM,  $F_{SW}=600kHz$ ,  $V_{OUT}=1.2V$ , unless otherwise noted.

**Load Transient**

$I_{OUT}=0A$  to 10A, 2.5A/ $\mu s$

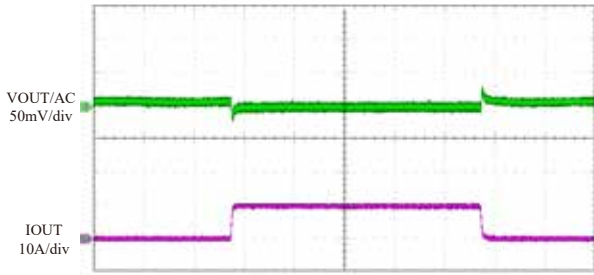

200 $\mu s$ /div

**Load Transient**

$I_{OUT}=0A$  to 20A, 2.5A/ $\mu s$

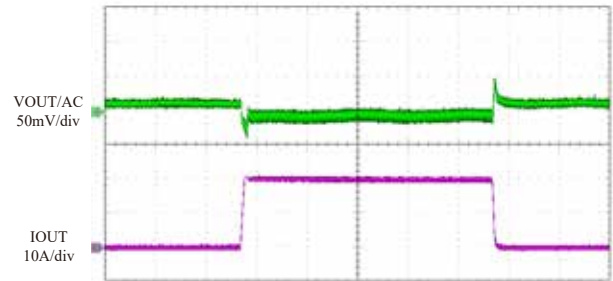

200 $\mu s$ /div

**Load Transient**

$I_{OUT}=10A$  to 20A, 2.5A/ $\mu s$

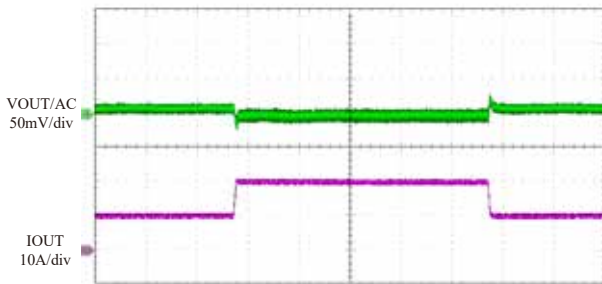

200 $\mu s$ /div

## OPERATION

The M1220 is a 15A Continuous, 20A Peak synchronous step-down switching mode Power SOC with integrated high-side and low-side power MOSFETs, inductor and input decoupling capacitor in QFN-29 (7.0mm×7.0mm×3.95mm) package. And the integrated input decoupling capacitor can minimize the parasitic inductance of input circuit and reduce the voltage spike on switching pin which simplify the PCB layout.

M1220 works on COT control mode that offers excellent transient response over a wide input voltage range. M1220 can provide excellent load regulation both Power Save Mode and Forced Continuous Conduction Mode for light load, which can be programmed by MODE pin. The switching frequency can also be programmed from 600kHz, 800kHz and 1MHz.

Fully integrated protection features include OCP, OVP, UVP and OTP and all these faults can be indicated by PG. The protection function details are shown below.

### OVER CURRENT PROTECTION (OCP)

M1220 has a cycle-by-cycle Low-Side valley current limit protection to prevent inductor current from running away. This current limit value can be programmed as shown in the **USER GUIDE**. When the Low-Side switch reaches the current limit, M1220 will enter hiccup mode.

OCP hiccup mode is active 3ms after M1220 is enabled. If M1220 detects an over-current condition for 31 consecutive cycles, or if  $V_{FB}$  drops below the UVP threshold, the device enters hiccup mode. Both High-side and Low-side MOSFETs latch off in hiccup mode. The REF/SS capacitor is also discharged. M1220 automatically tries to soft start after about 11ms.

If the over-current condition remains after 3ms of running, the M1220 repeats this operation cycle until the over-current condition disappears.

### OVER VOLTAGE PROTECTION (OVP)

M1220 monitors the output voltage by connecting FB to the net between the output voltage feedback resistors to detect an overvoltage condition. If  $V_{FB}$  exceeds 116% of  $V_{FB\_REF}$ , it triggers OVP. High-Side MOSFET turns off and the low-Side MOSFET turns on until reaching a negative current limit during this period. The low-Side MOSFET is turned off for 200ns upon reaching the negative current limit. After 200ns the Low-Side MOSFET turns on. The M1220 operates in this cycle until the output voltage is pulled down below 50% of the program point value.

The M1220 also employs output sinking mode (OSM) to regulate the output voltage to the targeted value when  $V_{FB}$  exceeds 104% of  $V_{FB\_REF}$  but is below the OVP threshold. During OSM, the LS-FET remains on until it reaches the negative current limit. Upon reaching, the LS-FET turns off for 200ns and the High-Side switch turns on during this period. After 200ns, the Low-Side switch turns on. The M1220 maintains this operation until  $V_{FB}$  drops below 102% of  $V_{FB\_REF}$ . Once it does, the M1220 exits OSM after 15 consecutive cycles of FCCM.

### OVER TEMPERATURE PROTECTION (OTP)

M1220 will stop switching when the junction temperature exceeds typically 160 °C. The device will power up again when the junction temperature drops below typically 130°C.

## USER GUIDE

### Output Voltage

The output voltage is programmed by the external feedback resistors as the typical application circuit on Page 1. The top feedback resistor  $R_1$  can impact the loop stability. The bottom feedback resistor  $R_2$  can be calculated as:

$$R_2 = \frac{R_1}{\frac{V_{OUT}}{V_{FB}} - 1}$$

Table 1 lists the recommended feedback resistor values for common output voltages. The resistance values of feedback resistors are recommended to be less than 20kΩ. And a feedforward resistor  $R_{FF}$  and capacitor  $C_{FF}$  are recommended for better load transient response.

**Table 1: FB Resistor Value for Common Output Voltages**

$V_{OUT}$	$R_1$	$R_2$
5V	8.2kΩ	1.1kΩ
3.3V	8.2kΩ	1.8kΩ
1.8V	4.02kΩ	2kΩ
1.2V	4.02kΩ	4.02kΩ
1.0V	2kΩ	3kΩ

### Input Capacitor Selection

The input current of the step-down converter is discontinuous with sharp edges; therefore, an input filter capacitor is necessary. For better performance, low ESR ceramic capacitor with X5R or X7R dielectrics are highly recommended because of their lowest temperature variations. The RMS current of the input capacitor is calculated:

$$I_{CIN\_RMS} = I_{OUT} \cdot \sqrt{D(1-D)}$$

in which D is the Duty Cycle and when the current is continuous,  $D=V_{OUT}/V_{IN}$ ;  $I_{OUT}$  is the output load current. As the equation above, when D is 0.5, the highest RMS current is approximately:

$$I_{CIN\_RMS} = \frac{I_{OUT}}{2}$$

So, it is recommended to choose the capacitor with the RMS current rating higher than  $1/2 I_{OUT}$ .

The power dissipation on the input capacitor can be estimated with the RMS current and the ESR resistor.

Electrolytic or tantalum capacitors can also be used. There is a small size 0.1μF ceramic capacitor placed closed to  $V_{IN}$  and GND in M1220 already. The input voltage ripple caused by the capacitor can be calculated as:

$$\Delta V_{CIN} = \frac{I_{OUT}}{F_{SW} \cdot C_{IN}} \cdot \frac{V_{OUT}}{V_{IN}} \cdot \left(1 - \frac{V_{OUT}}{V_{IN}}\right)$$

in which,  $F_{SW}$  is switching frequency.

### Output Capacitor Selection

An output capacitor is required to keep stable output voltage. To minimize the output voltage ripple, low ESR ceramic capacitors should be used. The output voltage ripple can be estimate as:

$$\Delta V_{OUT} = \frac{V_{OUT}}{8 \cdot F_{SW}^2 \cdot C_{OUT} \cdot L} \cdot \left(1 - \frac{V_{OUT}}{V_{IN}}\right)$$

In which, L is the inductor, which value is fixed at 0.33μH internally.

If electrolytic or tantalum capacitor are used, the ESR will dominate the output voltage ripple as:

$$\Delta V_{OUT} = R_{ESR} \cdot \frac{V_{OUT}}{F_{SW} \cdot L} \cdot \left(1 - \frac{V_{OUT}}{V_{IN}}\right)$$

### Power Good Indicator

M1220 has an open drain PG indicator. A pull-up resistor to VCC or any other power source less than 3.6V is needed if used and its recommended value is about 100kΩ. PG will be pulled down when the output voltage is out of regulation, otherwise PG is pulled up. PG goes high after a 0.9ms delay when the output voltage becomes within ±7.5% of the target value. The PG is latched low when  $V_{FB}$  drops to 80% or exceeds 116% of the regulation and will be pulled high after a new soft start.

### Mode Selection & Switching Frequency

M1220 can work on FCCM or PSM mode under the light load by selecting different resistor connected with MODE pin. **PSM mode means M1220 works at DCM under light load. FCCM mode means M1220 is forced to work at CCM under light load.** And the switching frequency is also programmed by this pin. Table 2 shows the value of the resistor for different operating mode and switching frequency.

**16V Input, 20A Step Down DC-DC Power SoC with Integrated Inductor**

**Table 2: Mode & Switching Frequency Selection**

MODE PIN	Light-Load Mode	F <sub>sw</sub>
VCC	PSM	600kHz
Float (Default)	PSM	800kHz
243kΩ (±10%) to GND	PSM	1000kHz
GND	FCCM	600kHz
34.8kΩ (±10%) to GND	FCCM	800kHz
80.6kΩ (±10%) to GND	FCCM	1000kHz

**Current limit**

M1220 features a current sense and a configurable current limit threshold. By using a resistor (R<sub>ILIM</sub>) from ILIM to GND, the current limit is program as:

$$\frac{R_{ILIM}(M\Omega) \times 0.01}{R_{ILIM}(M\Omega) + 0.01} = \frac{V_{ILIM}}{G_{CS} \cdot (I_{LIM} - \frac{(V_{IN} - V_{OUT}) \cdot V_{OUT}}{V_{IN}}) \cdot \frac{1}{2F_{SW}(MHz) \cdot L(\mu H)}}$$

in which, V<sub>ILIM</sub>=1.2V, G<sub>CS</sub>=10μA/A, L=0.33μH.

Table 3 shows the recommended value of the resistor R<sub>ILIM</sub> for different operating mode.

**Table 3: R<sub>ILIM</sub> & Operation**

Operation	F <sub>sw</sub>	I <sub>LIM</sub> (TYP)	R <sub>ILIM</sub>
V <sub>IN</sub> =12V, V <sub>OUT</sub> =5V	600kHz	18A	NC
V <sub>IN</sub> =12V, V <sub>OUT</sub> =3.3V	600kHz	19A	140kΩ
V <sub>IN</sub> =12V, V <sub>OUT</sub> =1.8V	600kHz	20A	28kΩ
V <sub>IN</sub> =12V, V <sub>OUT</sub> =1.2V	600kHz	20A	22kΩ
V <sub>IN</sub> =12V, V <sub>OUT</sub> =1V	600kHz	20A	21kΩ

**Soft Start Time**

M1220 has 1.5ms default soft-start timer internally. The time can be increased by adding an external capacitor C<sub>SS</sub> between REF/SS and GND. C<sub>SS</sub> can be calculated as:

$$C_{SS}(nF) = \frac{T_{SS}(ms) \times 36(\mu A)}{0.6(V)} - 100nF$$

**VIN Pin High Frequency Bypass and Snubber Circuit Recommendation**

To operate the M1220 within absolute maximum ratings without ringing issue, some reduction techniques may

require external components to further ringing levels. A lossless way is using a high frequency bypass capacitor on the VIN pins by minimizing the power loop parasitic inductances. A 4.7nF capacitor still be recommended to be connected to 29 PIN. As the placement of this capacitor is critical to its effectiveness. The ideal placement is shown in PCB layout guidelines.

A R-C snubber circuit can also be recommended to achieve a lower ringing level. As a reference, two 2Ω resistors in parallel and 1nF capacitor between SW and GND are recommended.

**PCB Layout Guide**

To optimize the electrical and thermal performance, some PCB layout guidelines should be considered as below:

1. Use wide trace for the high current paths and keep it as short as possible. It helps to minimize the PCB conduction loss and thermal stress.
2. The M1220 has integrated the input decoupling capacitor, and **it is also recommended to place other input decoupling capacitors close to VIN and PGND to minimize the power loop as shown as (f).**
3. Connect all feedback network to FB shortly.
4. Keep the sensitive components away from the SW.
5. The PGND should be connected to a strong ground plane for better heat dissipation and noise protection.
6. M1210 supports remote voltage sense to compensate any voltage drop in the leads/traces. Make Sure that differential lines are used to do Output Voltage Sense from capacitor terminals.

Figure 1 gives a good example of the recommended layout.

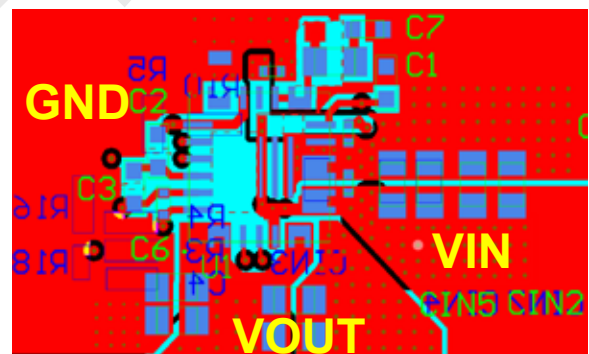

(a) Top Layer

16V Input, 20A Step Down DC-DC Power SoC with Integrated Inductor

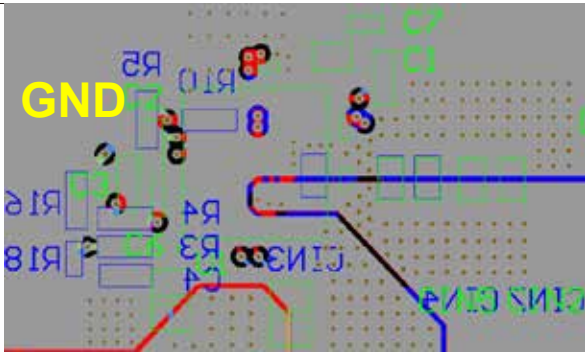

(b) Inner Layer 2

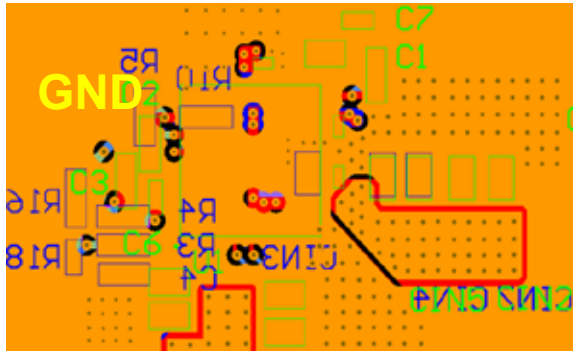

(c) Inner layer 1/3/4

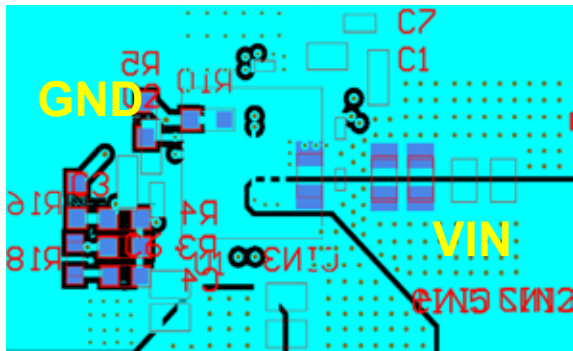

(d) Bottom Layer

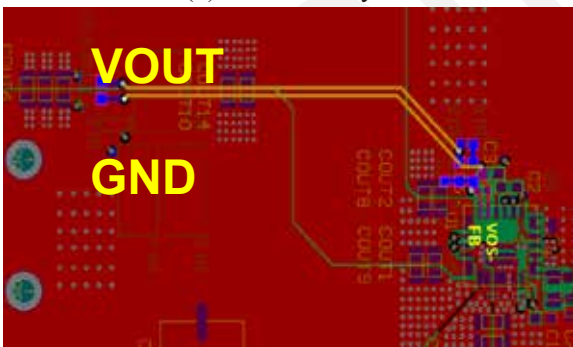

(e) Remote Sense Traces

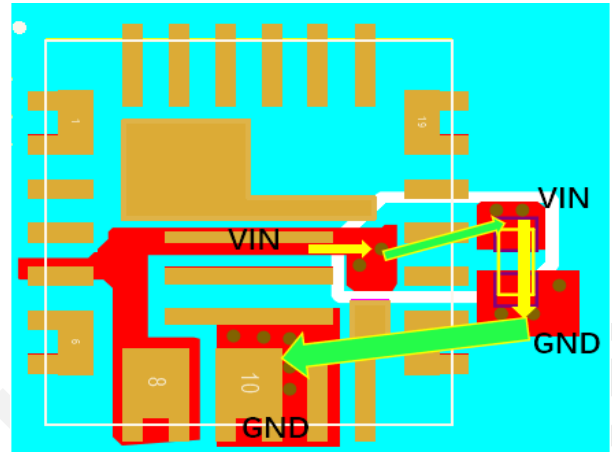
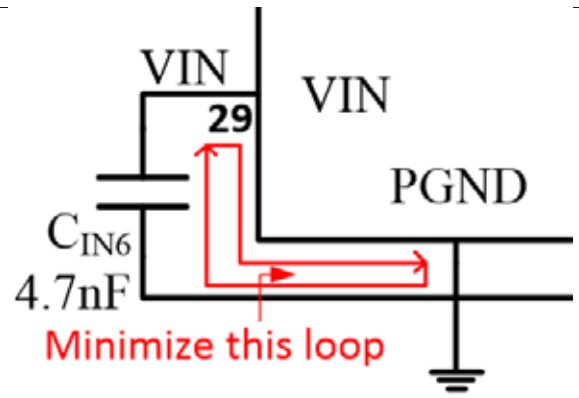

(f) Input Decoupling Cap

Figure 1. Recommended Layout

## TYPICAL APPLICATION

● VIN=12V

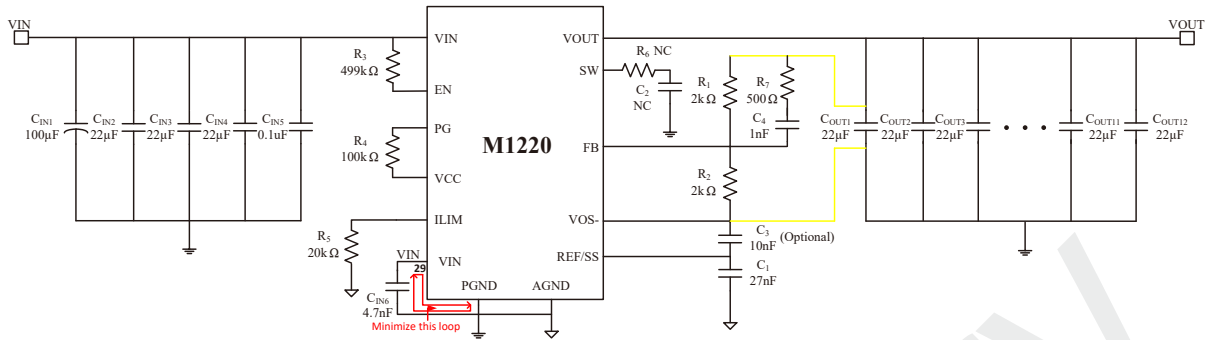

Figure 2. Typical Application Circuits of M1220 for 12V Input 1.2V@20A Output, Fsw=600kHz

**NOTE:** 1) R<sub>6</sub> and C<sub>2</sub> are Snubber circuit to minimize ringing level, which are not connected (NC) if not used.

2) R<sub>7</sub> and C<sub>4</sub> are forward network to improve transient response ability, which are optional.

**Table 4: M1220 Reference Design for 12V Input**

VOUT	CIN	COUT	Target Vout Ripple	R1	R2	R5	I <sub>LIM</sub> TYP (Fsw=600kHz)
5.0V	100uF(E-CAP) +3×22uF	15×22uF	45mV	8.2kΩ	1.1kΩ	NC	18A
3.3V	100uF(E-CAP) +2×22uF	14×22uF	35mV	8.2kΩ	1.8kΩ	140kΩ	19A
1.8V	5×22uF	12×22uF	20mV	4.02kΩ	2kΩ	28kΩ	20A
1.2V	4×22uF	10×22uF	20mV	4.02kΩ	4.02kΩ	22kΩ	20A
1.0V	4×22uF	9×22uF	20mV	2kΩ	3kΩ	21kΩ	20A

**NOTE:**

CIN is the sum of the input capacitors, COUT is the sum of the output capacitors, please refer to Figure 2 for parameters of other components.

● VIN=5V

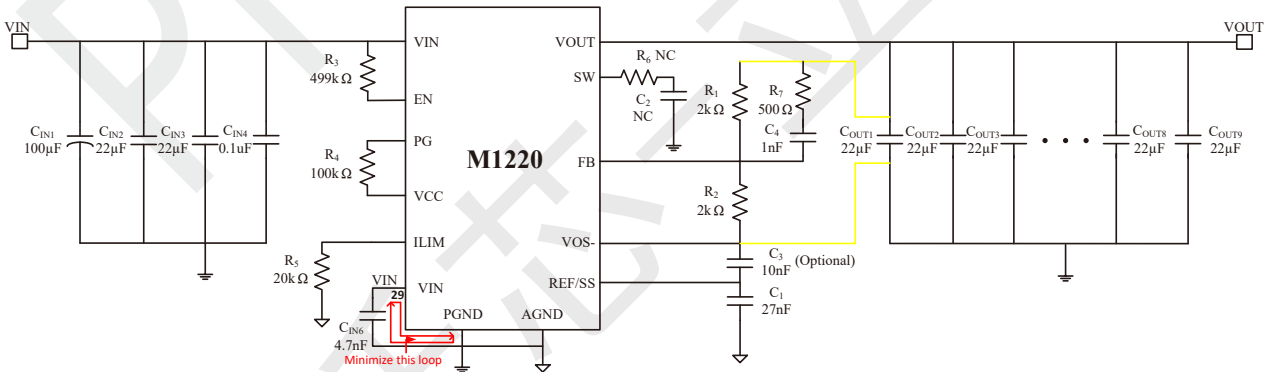

Figure 3. Typical Application Circuits of M1220 for 5V Input 1.2V@20A Output, Fsw=600kHz

**NOTE:** 1) R<sub>6</sub> and C<sub>2</sub> are Snubber circuit to minimize ringing level, which are not connected (NC) if not used.

2) R<sub>7</sub> and C<sub>4</sub> are forward network to improve transient response ability, which are optional.



**16V Input, 20A Step Down DC-DC Power SoC with Integrated Inductor****Table 5: M1220 Reference Design for 5V Input**

VOUT	CIN	COUT	Target Vout Ripple	R1	R2	R5	I <sub>LIM</sub> TYP (F <sub>sw</sub> =600kHz)
3.3V	100uF(E-CAP) +2×22uF	14×22uF	35mV	8.2kΩ	1.8kΩ	140kΩ	19A
1.8V	5×22uF	12×22uF	20mV	4.02kΩ	2kΩ	28kΩ	20A
1.2V	4×22uF	10×22uF	20mV	4.02kΩ	4.02kΩ	22kΩ	20A
1.0V	4×22uF	9×22uF	20mV	2kΩ	3kΩ	21kΩ	20A

**NOTE:**

CIN is the sum of the input capacitors, COUT is the sum of the output capacitors, please refer to Figure 3 for parameters of other components.

**PACKAGE INFORMATION**

QFN-29 (7.0mm×7.0mm×3.95mm) Package

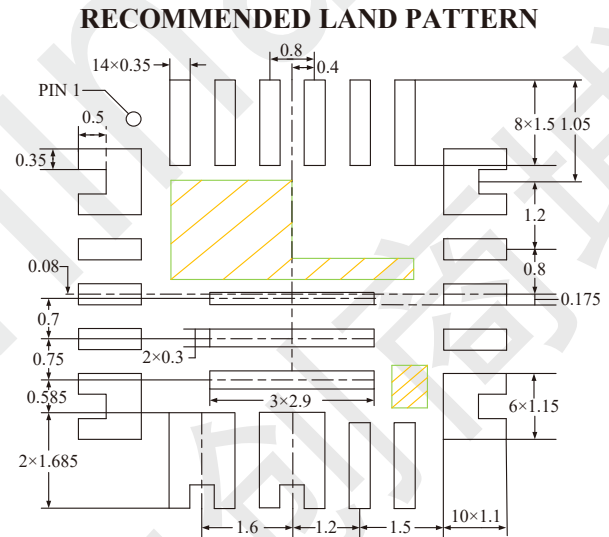
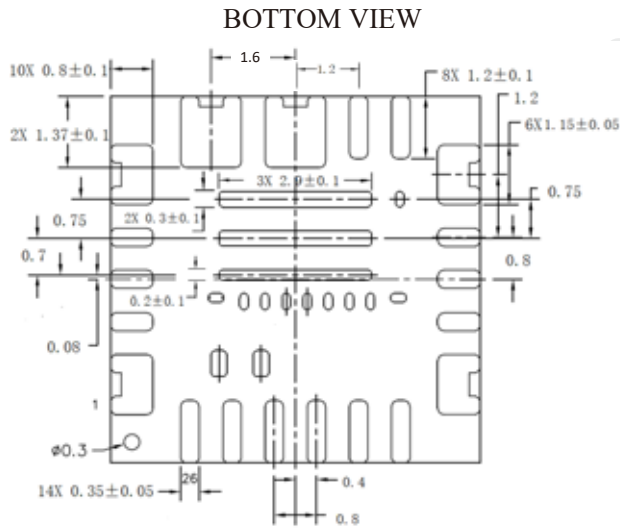
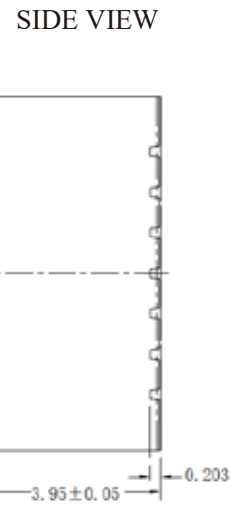
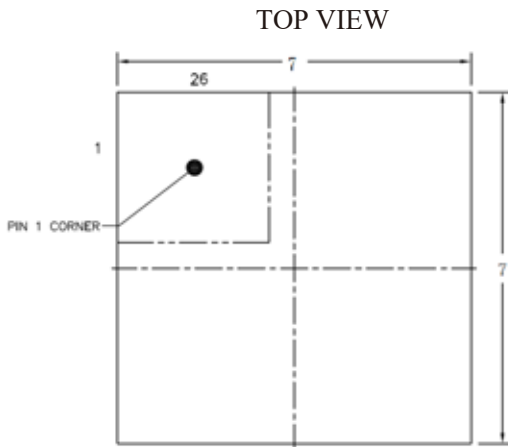

**NOTE:**

- 1) All dimensions are in MM.
- 2) The shaded area is the keep-out zone. Not to connect to any electrical or mechanical area.

**CARRIER INFORMATION**

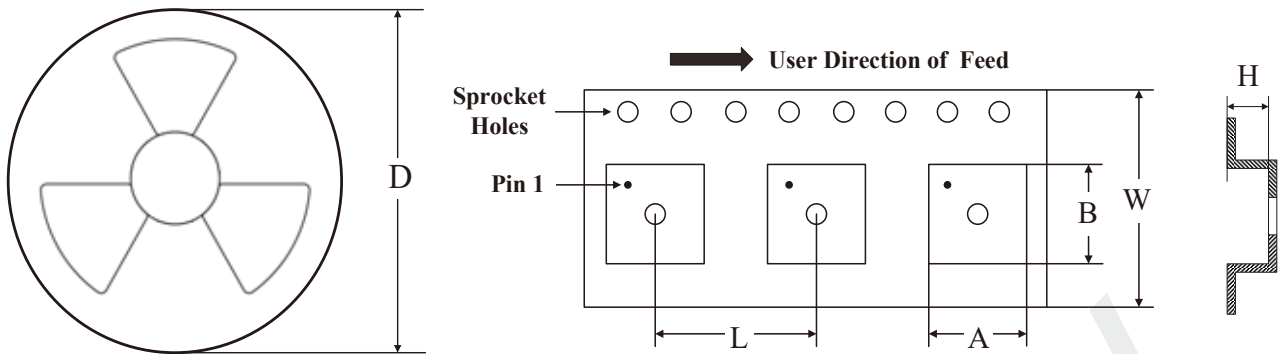

Part Number	Package	Quantity /Reel	D	A	B	L	W	H
M1220DQEE	QFN-29 (7.0mm×7.0mm×3.95mm)	1000	13 in	7.7mm	7.7mm	12mm	16mm	4.2mm