



Customer 客户: _____

Lithium-ion Battery
Specification Approval Sheet
锂离子电池规格确认书

Model 型号: Li-18650-1S1P- 3.7V -2600mAh-PCM

File number 成品编码: _____

Approved by 批准	Checked by 审核	Prepared by 编制	Date 日期
肖东云		陈庆聪	2021.08.17

Customer signature 客户签署

Client Confirmation 客户确认	签名盖章
Date 日期	
Please sign back specification before bulk order 批量订单前请回签规格书	

深圳市康胜新能源产品有限公司

Shenzhen Kamcy New Energy Products Co., Ltd.

地址: 深圳市宝安区西乡铁岗水库路创富工业区 3 栋 2 楼

Add: Chuangfu Industrial Zone, Shuiku Road, Tiegang, Xixiang Town, Bao'an District, Shenzhen, China.

电话: 0755-27346890 传真: 0755-27675160



Contents 目录

1.Scope 范围	-----
2.Product Configuration 产品配置	-----
3.Product Dimension 产品尺寸	-----
4.Product Specification 产品规格	-----
5.Product Electric Performance Test 产品电性能测试	-----
6.Mechanical Performance 机械特性	-----
7.PCM Specification 保护板规格	-----
8.Storage and Transportation 储存和运输	-----
9.Warning 注意事项	-----
10.Period of Warranty 保质期	-----
11.Others 其他	-----
12.Note 备注	-----

1 Scope 范围

本规格书描述本公司设计开发的电池，它是产品设计、生产和检验的依据。其作用是让顾客了解产品的质量及正确使用方法。

This specification describes the design and development of the company's battery; it is the product of design, production and inspection basis. Its role is to understand the quality of the product and using the correct method for customers.

本规范适用于由深圳市康胜新能源产品有限公司制造的锂离子电池产品。

This specification shall be applied to Li-ion battery manufactured by Shengzhen KAMCY Battery Co.,Ltd.

2 Product Configuration 产品配置

No.	Item 项目	Criteria 标准	Remark 备注
1	电芯 Lithium-ion Battery Cell	Li-18650-3.7V -2600	
2	PCM	PCM-F3.7V-27*3.8*0.6	2738-8L
3	Connector	UL1007 24#	

3 Product Dimension 产品

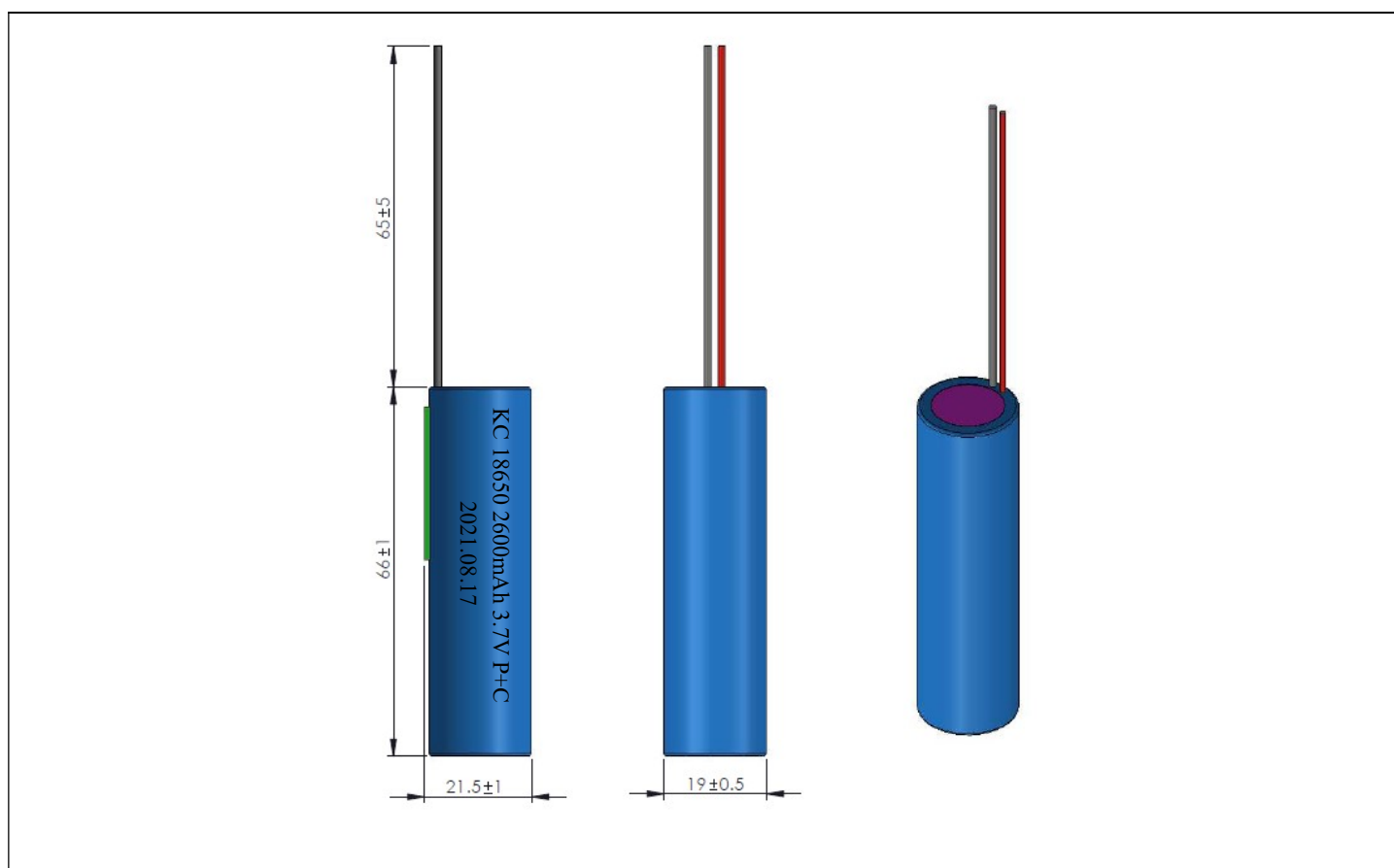

N O	电池类型 Battery type	电池尺寸 (mm)Dimensions D*H (max)	导线长度 (mm) Lead exposure L	端子头方向 Terminal head direction	浸锡长度 Immersion tin size
1	锂离子圆柱 Li-ion Cylindrical	19.5*22.5*67mm	65±5	/	/



4 Product Specification 产品规格

No.	内容 content	测试方法 Testing method	备注 Remark
1	充电截止电压 Charge cut-off voltage	4.2V	
2	放电终止电压 Discharge cut-off voltage	2.75V	
3	标准充电模式 Standard charge	在环境温度 $25 \pm 2^\circ\text{C}$ 条件下，以0.2C电流恒流充电至4.2V，转4.2V恒压充电，直到充电电流 $\leq 0.02\text{C}$ 。Under the condition of the ambient temperature of $25 \pm 2^\circ\text{C}$, Charge the battery at constant current of 0.2C to reach 4.2V. Then charge the battery at constant 4.2V voltage until the charging current decreasing to 0.02C.	
4	标准放电模式 Standard discharge	以标准充电模式满充后，搁置1小时，以0.2C电流恒流放电至2.75V。 After the standard charging, rest for 1 hour then discharge to 2.75V@0.2C.	
5	出货电压 Shipments voltage	$\geq 3.80\text{V}$	
6	最大充电电流 Maximum Charge Current	0.5C	
7	最大持续工作电流 Maximum continuous working current	2A	
8	容量 Rated capacity	标称容量Typical capacity: 2600mAh 最小容量Minimum capacity: 1850mAh	标准充电然后标准放电 standard discharge after standard charge
9	工作温度 Operation temperature range	充电: $10 \sim 45^\circ\text{C}$ 放电: $-10 \sim 45^\circ\text{C}$	湿度: $60 \pm 25\%$ $60 \pm 25\% \text{R.H}$
10	储存温度 Storage temperature	小于1个月: $-20 \sim 45^\circ\text{C}$ $\leq 1 \text{ month: } -20 \sim 45^\circ\text{C}$ 小于3个月: $-10 \sim 30^\circ\text{C}$ $\leq 3 \text{ months: } -10 \sim 30^\circ\text{C}$ 小于1年: $0 \sim 30^\circ\text{C}$ $\leq 1 \text{ year: } 0 \sim 30^\circ\text{C}$	湿度: $60 \pm 25\%$ 长时间储存最佳温度: $10 \sim 25^\circ\text{C}$ $60 \pm 25\% \text{R.H}$ Best $10 \sim 25^\circ\text{C}$ for long-time storage
11	内阻 Impedance	$< 160\text{m}\Omega$	
12	重量 Weight	Approx:	

5 Product Electric Performance Test 产品电性能测试

No.	项目 Items	测试方法 Test Conditions	达到要求 Requirements
1	荷电保持能力 Capacity retention	以标准模式充电后，在环境温度 20℃±5℃的条件下，将电池开路搁置 28d，再以 0.2C 电流进行放电至 2.75V。 Fully charging, store them at (20±5)°C for 28 days, then discharge to 2.75V @0.2C.(the residual capacity is above 85% of nominal capacity)	放电时间≥4.25h Discharging time≥4.25h
2	常温循环寿命 Cycle Life @25°C	以 0.2C 电流恒流放电至 2.75V，再以 0.2C 电流恒流充电至 4.2V，然后恒压 4.2V 充至电流≤0.02C，静止 10min，以 0.2C 电流恒流放电至 2.75V，放电结束后，静止 10min，再进行下一充放循环，直至连续三次放电容量小于 80% 的 0.2C 的首次放电容量。 Discharge to 2.75V @0.2C, then Charge the battery @0.2C to reach 4.2V. Then charge the battery at constant 4.2V voltage until the charging current decreasing to 0.02C. Rest for 10 min. discharge to 2.75V@ 0.2C and rest for 10 min. Continue the charge/discharge cycles until discharge capacity lower than 80% of rated capacity.	循环次数≥500 次 Cycles life ≥500
3	储存 storage	以标准模式充电给电池充入 40%~65%的容量，然后在环境温度 20℃±5℃，相对湿度 45%~85%的环境中贮存。贮存 12 个月满充以 0.2C 电流放电至终止电压。 进行贮存试验的电池应选自生产日期到试验日期不足 3 个月的电池。 Charge the battery to 40%~65% of its rated capacity using standard charging mode, then keep it in an 20℃±5℃, humidity 45%~85% room for 12 months, fully charge and discharge it @0.2C until voltage down to 2.75V. (The testing sample should be within 3 months dated from production date)	放电时间≥4h Discharge time≥4h

6 Mechanical Performance 机械特性

序号 No.	内容 content	测试方法 Testing method	达到要求 Requirements
1	振动实验 Vibration Test	电池标准充电后固定在振动台上，以 X, Y, Z 三个方向从 10Hz~55Hz 循环振动各 30min，扫描速率为 1oct/min；振动频率：10Hz~30Hz；移位振幅/单振幅：0.38mm；振动频率：30Hz~55Hz；移位振幅/单振幅：0.19mm。 After standard charging, put battery on the vibration table. 30 min experiment from X, Y, Z axis. Scan rate: 1oct/min; Frequency 10-30Hz, Swing 0.38mm; Frequency 30-55Hz, Swing 0.19mm.	电性能及外观不受影响 No influence to batteries' electrical performance and appearance.
2	跌落试验 Drop Test	电池标准充电后从 1.0m 高处任意方向落至木板上 6 次。 Random drop the battery from 1.0m height onto wood board 6 times.	不爆炸 不着火 No explosion or fire

7 PCM Specification 保护板规格

7.1 保护板布局图 PCM layout

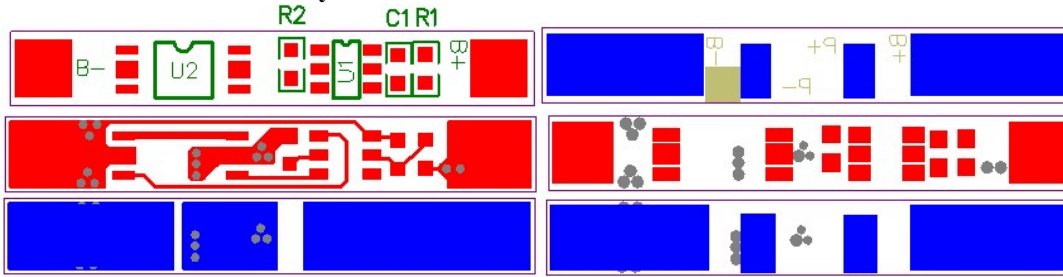

7.2 保护板原理图 Application Circuit

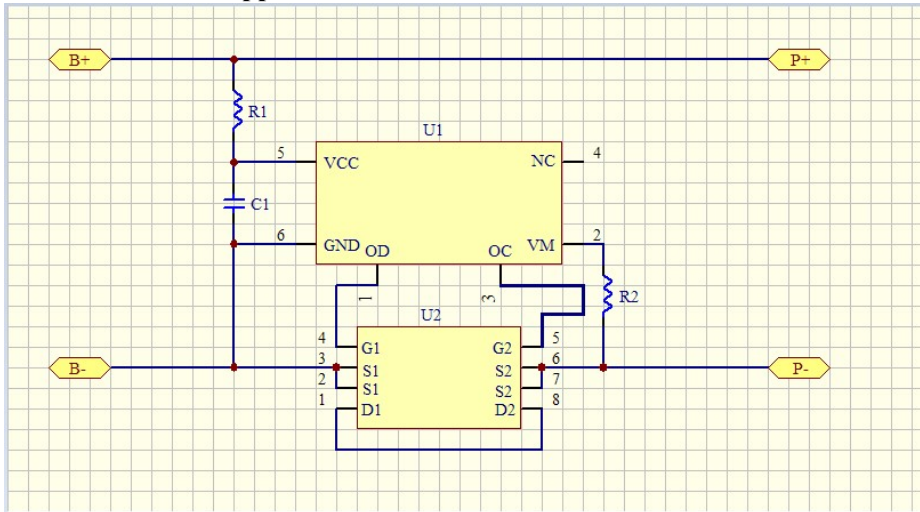

7.3 PCM 参数

项目 Item	参数值 Parameter Value	单位 Unit
过充电检测电压 Overcharge detection voltage	4.23-4.28-4.33	V
过充电保护延时 Overcharge protection delay	150-340-500	mS
过充电解除电压 Overcharge release voltage	4.03-4.08-4.13	V
电量平衡检测电压 Battery balance detection voltage	/	V
电量平衡电流 Electricity balance current	/	mA
过放电检测电压 Overdischarge detection voltage	2.30-2.40-2.60	V
过放电检测延时 Overdischarge detection delay	80-200-300	mS
过放电解除电压 Over discharge discharge voltage	2.90-3.00-3.10	V
过电流检测电压 Overcurrent detection voltage	120-150-180	mV
过电流检测延时 Overcurrent detection delay	5-15-20	mS
过电流保护电流 Overcurrent protection current	2.0-3.5-5.5	A
过电流保护解除条件 Overcurrent protection release conditions	断开负载 Disconnect the load	/
短路检测延时 Short circuit detection delay	≤50	uS
短路保护解除条件 Short circuit protection release conditions	断开负载 Disconnect the load	
温度保护 Temperature protection	/	°C
主回路导通内阻 Main circuit conduction resistance	≤65	mΩ
自耗电 Self-consumption	工作功耗 Working power consumption	1.0-3.0-6.0 uA
	休眠功耗 Sleep power consumption	≤0.1 uA
工作温度 Operating temperature	-40~+85	°C

8 Storage and Transportation 储存和运输

8.1 Storage 储存

- 8.1.1 The Li-ion battery pack should be stored in a cool, dry and well ventilated area avoiding exposure to heat and high temperatures. Do not place the battery in direct sunlight or heat.
锂离子电池需保存在阴凉, 干燥, 通风的环境中, 避免接触火源与热源。
- 8.1.2 The battery should be stored in accordance with the manufacturer's specifications. Ideally, a temperature of $25\pm 5^{\circ}\text{C}$ and humidity of $60\pm 15\%$ is recommended.
电池需按规格书规定温度范围进行储存, 最佳储存温度为 $25\pm 5^{\circ}\text{C}$, 最佳湿度为 $60\pm 15\%$ 。
- 8.1.3 The battery should be stored within the recommended room temperatures with a charge of 40%-60% of rated capacity. In order to avoid over-discharge, we suggest charging and discharging the batteries every three (3) months, then charge to 40%-60% of rated capacity.
电池应当在室温下存放, 应充到 40%至 60%的电量。为防止电池过放, 建议每 3 个月按标准充放电方式进行一次充放电, 然后按标准充电方式进行充电至 40%~60%的电量。

8.2 Transportation 运输

- 8.2.1 Do not mix the battery products with other cargos.
请勿与其他货物混合。
- 8.2.2 Do not immerse the battery products in water or allow it to get wet.
请勿将电池浸入水中或使其受潮。
- 8.2.3 Do not stack battery cartons over 7 high or stack upside down.
请勿叠放超过 7 层或倒置。
- 8.2.4 The highest temperature in transportation is lower than 65°C .
最高运输温度不超过 65°C 。

9 Warning 注意事项

- 9.1 为确保安全, 电池应安装安全装置, 在静电强于制造时所要求的静电时请勿使用, 否则, 安全装置会失效, 导致电池过热、破裂、爆炸及着火。
Use proper Electrostatic Discharge (ESD) handling methods to avoid damaging the battery. Exposure to ESD may damage the battery protection devices which may lead to overheating, rupture, explosion and fire.
- 9.2 请在下列条件下正常使用, 否则会过热、着火、性能降低及缩短寿命。
In the normal use of the following conditions, otherwise they will overheat and catch fire, performance and shorten the life.
环境条件 Ambient condition: (T 温度 temperature)
充电 charging: $10\sim +45^{\circ}\text{C}$
放电 discharging: $-10\sim +45^{\circ}\text{C}$
- 9.3 为避免人员受伤或财产损坏, 电池应由合适的人员使用。电池应远离婴幼儿和宠物。
Batteries should be handled by qualified personnel only to avoid injuries or property damage. Keep the battery away from children and pets.
- 9.4 若电池泄露, 电解质粘于皮肤或衣服上, 请用水冲洗掉或用流水洗衣服, 否则将会腐蚀皮肤。
Avoid contact with leaking batteries as electrolytes may cause burns to skin and damage to clothing. In the event electrolytes make contact, wash effected areas with water and seek medical attention if necessary.
- 9.5 为了不装错或损耗电池, 请认真阅读使用说明书, 并按照指导进行安装与拆卸(从装置上)。
In order to avoid damage to the battery and devices, carefully read and understand the operating instructions for proper installation, use and removal of the battery in the device.
- 9.6 若电池不长期使用, 请把电池拿出并放于干燥的地方, 否则电器将会被腐蚀电池降低性能和减少寿命。
If the battery is not intended to be used for an extended period of time, remove the battery and store it in a cool dry place per the manufacturer's specifications. This will prevent damage to the appliance while preserving the battery life and performance.
- 9.7 为防止损坏电池或设备, 应保持电池接头触点清洁, 没有任何污染物。请使用合适的清洁产品清洁电池表面和触点, 如干布。
Ensure the battery connector contacts are clean and free of any contaminants to prevent damage to the battery and



device. Use only approved cleaning products, such as a dry cloth, to clean surface and contacts.

9.8 远离儿童，不要让儿童在没有成人监督的情况下更换电池。

Keep out of the reach of children, Do not allow children to replace batteries without adult supervision.

10 Product responsibility 产品责任

您必须严格遵守我司规格书和文件后面的注释使用电池，由于误用会引起电池过热，发生火灾或爆炸。对于没有按照规格书进行操作所造成的任何以外事故，我司不承担任何责任。

You must strictly adhere to our specifications and documentation comment later, due to the misuse of batteries can cause the battery to overheat, fire or explosion. For the specification for any accidental, I Secretary does not bear any responsibility.

如果规格书、原材料、生产过程或生产控制系统发生改变，改变的信息将会随质量和可靠性数据以书面形式通知消费者。

If the specification, raw materials, production processes or production control system is changed, the change of information will vary depending on the quality and reliability data to inform consumers in writing.

电池的保质期从出货之日算起为一年。如果证明电池的缺陷是在制造过程中形成的而不是由于用户滥用及错误使用造成，本公司负责退换电池

The period of warranty is one year from the date of shipment. KAMCY guarantees to give a replacement in case of cells with defects proven due to manufacturing process instead of the customers abuse and misuse.

11 Others 其他

因为电池是利用化学反应，电池的性能会随时间恶化，即使存放很长一段时间没有被使用。此外，如果使用条件如充电，放电，温度，等不在指定的范围内的电池的寿命可能会缩短或设备中的电池使用的电解质渗漏损坏的可能。如果电池无法保持长时间的充电，即使充电正确，这可能表明是时候更换电池。

Because batteries utilize a chemical reaction, battery performance will deteriorate over time even if stored for a long period of time without being used. In addition, if the various usage conditions such as charge, discharge, ambient temperature, etc. are not maintained within the specified ranges the life expectancy of the battery may be shortened or the device in which the battery is used may be damaged by electrolyte leakage. If the batteries cannot maintain a charge for long periods of time, even when they are charged correctly, this may indicate it is time to change the battery.

12 Note 备注

其他项目不包括在本规范应经双方同意。

Any other items which are not covered in this specification shall be agreed by both parties.