

MAPX	MODIFICATION	DATE
------	--------------	------

Note:
1. Material:
1.1, Housing: High temperature thermoplastic with/black G/F, UL94V-0
1.2, Contact: copper alloy, t=0.25mm
1.3, Shell: copper/Ferroalloy alloy, t=0.30mm

2. Specification:
2.1, Current rating: 5A Max.
2.2, Dielectric withstanding voltage: 100 V(ac) for 1 min.
2.3, Contact resistance: 30 mΩ Max.
2.4, Insulation resistance: 100 MΩ Min.
2.5, Total mating force: 3.57 Kgf Max.
2.6, Total unmating force: 1.0 Kgf Min.

3. Finish:
3.1, Contact: Plated Gold in Mating Area:
Tin On Solder Tails

Shell: Nickel Plating

4. Environmental:
4.1, Temperature range: -55°C~85°C

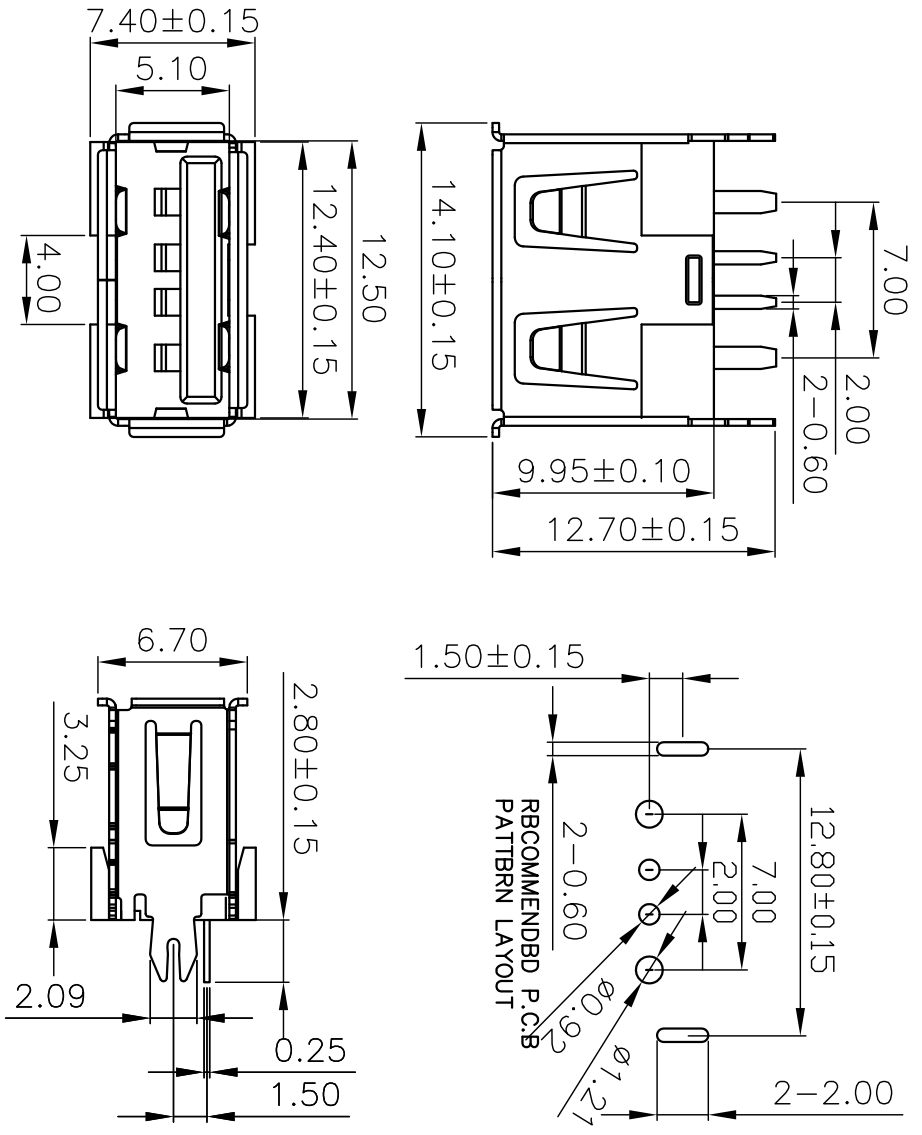

产品图
PRODUCT CHART DWG

公差—倍率
TOLERANCE UNLESS OTHERWISE

X.	±0.30	X.	±5.°
.X	±0.25	.X	±2.°
.XX	±0.15	.XX	±1.°
.XXX	±0.10	.XXX	±0.5°

深圳市精拓金电子有限公司

单位 UNITS	MM	制图 DRAWING	YANG	制图料号 PRODUCT PART NO.	916-352A1094Y10210
比例 SCALE	1:1	审核 CHECK	郭志富	产品名称 PRODUCT NO.	16次电流10.0短体80度鱼叉脚有边排壳可绝缘
日期 DATE	2019.11.23	核准 APPRO	黄国荣	角法 VIEW	⊕ ⊖
				版本 VER	A0

