



SPECIFICATION

Surface Acoustic Wave Filter

USER

USER PART No.

WISOL PART No. **SFH881CA402**

DOC. No. SMS-51-L-SFT FX-113

DATE Feb 14, 2018

REVISION Preliminary

WISOL					
ISSUED BY	Kim, Kyung-Sik 	APPROVED BY (R&D)	Ha, Sang-Ki 	APPROVED BY (QC)	Hong, Sang-Dea 
User					
ISSUED BY		CHECKED BY		APPROVED BY	

WISOL CO., LTD.
531-7, Gajang-ro, Osan-si,
Gyeonggi-do, KOREA, 18103
<http://www.wisol.co.kr>

▶ A TABLE OF CONTENTS

1. REVISION HISTORY	3
2. DEFINITION	4
3. PRECAUTIONS	4
4. OUTLINE DRAWING & DIMENSIONS	5
5. MARKING	6
6. PERFORMANCE	7
6-1. MAXIMUM RATINGS	7
6-2. ELECTRICAL CHARACTERISTICS	8
7. RELIABILITY	10
7-1. ENGINEERING SAMPLE FLOW CHART	10
7-2. TEST ITEM & CONDITION	11
8. REFLOW CONDITION	12
9. RECOMMENDED PCB DIMENSIONS	12
10. CAUTION	13
11. PACKING	14
11-1. DIMENSIONS	14
11-2. REELING QUANTITY	15
11-3. TAPING STRUCTURE	15
11-4. INNER BOX(Reel Packing) STRUCTURE	16
11-5. OUTER BOX STRUCTURE	17
12. TAPE SPECIFICATIONS	18
13. RoHS DATA	19

1. REVISION HISTORY

Preliminary	Feb 14, 2018	All Page	Make specification
-------------	--------------	----------	--------------------

2. DEFINITION

2-1. PART No.

SFH881CA402

① ② ③ ④ ⑤ ⑥

No.	EXPLANATION
①	SAW Filter
②	Design Type
③	Center Frequency :881.5MHz(869 ~ 894)
④	Input:50ohm,Output:50ohm
⑤	Package size: 1.1×0.9mm ²
⑥	Design Revision (02 : Molding Type)

2-2. APPLICATION : Band-Pass Filter for B5 Rx

3. PRECAUTIONS

3-1. This device should not be used in any type of fluid such as water, oil, organic solvent, etc.

3-2. This is a hermetic device.

MSL(Moisture Sensitive Level) is the '2a' level.

3-3. Ultrasonic cleaning shall be avoided.

3-4. Isopropyl Alcohol and Ethyl Alcohol can be used for cleaning. Contact us before using other cleaning solvents than above

3-5. This is an electrostatic sensitive device.

Please avoid static voltage during operation and storage.

3-6. Sudden change of temperature shall be avoided, deterioration of the characteristics can occur.

3-7. If any malfunction due to designing or manufacturing which is out of specification occurs within one year after the products have been delivered, the maker should exchange the defective products.

4. OUTLINE DRAWING & DIMENSIONS

[Unit: mm]

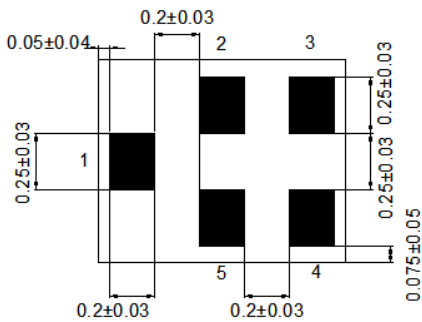
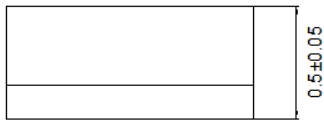
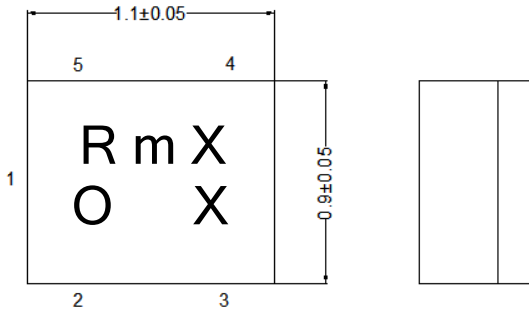

No.	Function
2, 3, 5	Ground
1	Unbalanced Input
4	Unbalanced Output

5. MARKING

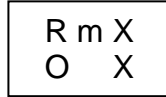

5-1. R m X X

- The 1st 2nd character 'Rm' indicates the model name of SAW Filter SFH881CA402.
- The 3rd character 'X' indicates the year and the month of manufacture.

Year	Month											
	1	2	3	4	5	6	7	8	9	10	11	12
2017	1	2	3	4	5	6	7	8	9	A	B	C
2018	D	E	F	G	H	I	J	K	L	M	N	O
2019	P	Q	R	S	T	U	V	W	X	Y	Z	a
2020	1	2	3	4	5	6	7	8	9	A	B	C

※ This rotates by the 3 years.

- The 4th character 'X' indicates Lot No.

5-2. ○

- This symbol indicates input pin 1.
- This indicates the producing center
 - : China

5-3. Marking : Laser Marking

6. PERFORMANCE

6-1. MAXIMUM RATINGS

CHARACTERISTICS	RATINGS	UNITS	NOTES
DC Permissive Voltage	5	V	
Maximum Input Power	15	dBm	
Operating Temperature Range	- 30 ~ +85	°C	
Storage Temperature Range	- 40 ~ +85	°C	

6-2. ELECTRICAL CHARACTERISTICS
6-2-1. TABLE

Ta = - 30 ~ +85℃

*1.PCB loss is de-embedded.

Item	FREQUENCY RANGE [MHz]	UNIT	SPECIFICATION		
			Min.	Typ. (25℃)	Max.
Insertion Loss(*1)	869~894	dB	-	1.3	1.9
Inband Ripple	869~894	dB	-	0.4	1.1
Input VSWR	869~894	-	-	1.7	2.2
Output VSWR	869~894	-	-	1.7	2.2
Absolute Attenuation	824~849	dB	36	42	-
	1559.05~1563.15	dB	35	39	-
	1573.42~1577.42	dB	35	39	-
	1597.55~1605.89	dB	35	39	-
	1738~1788	dB	35	40	-
	2400~2500	dB	37	43	-
	5000~5830	dB	33	37	-
Termination Impedance		Input: Unbalanced 50 ohm Output: Unbalanced 50 ohm			

6-2-2. TEST FIXTURE

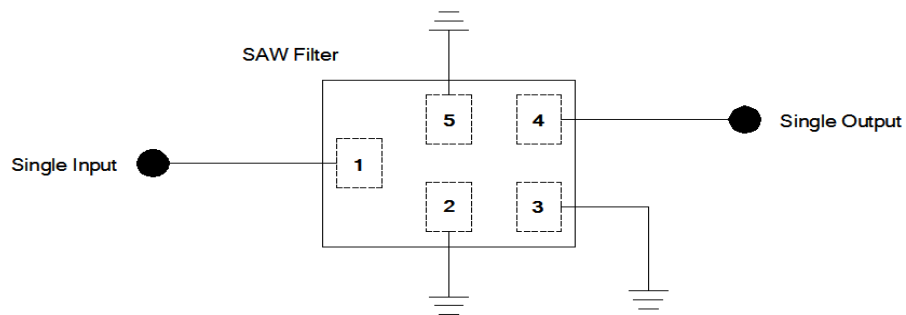

[X-Ray Top View]

6-2-3. GRAPH

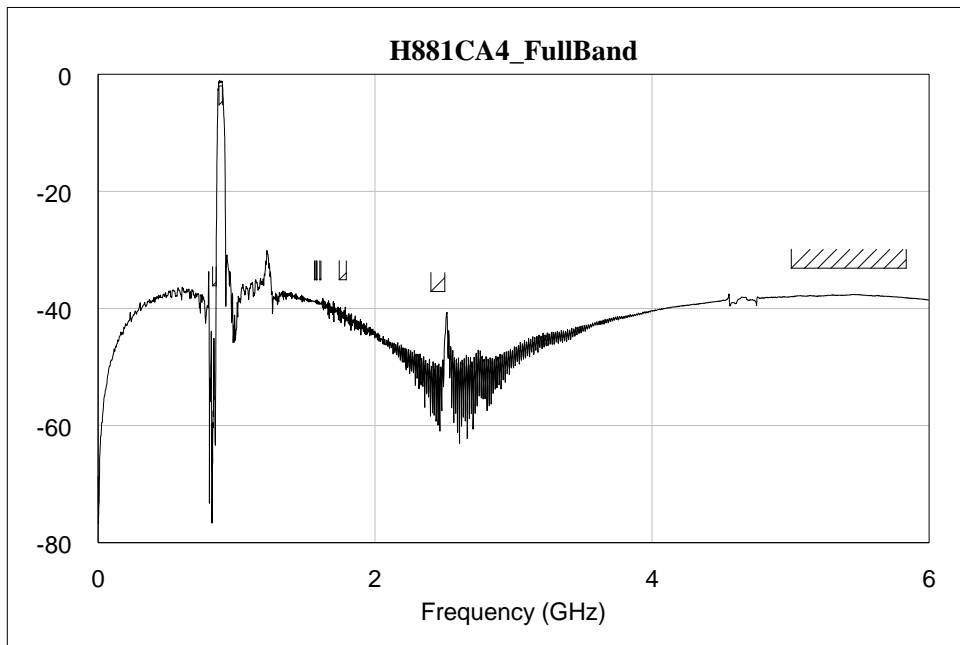
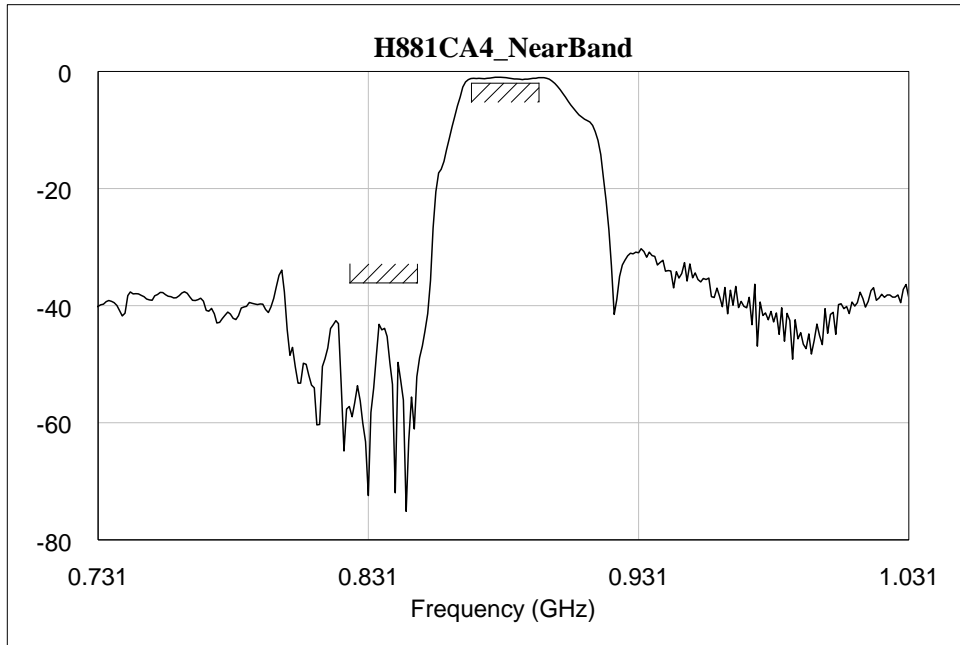

7. RELIABILITY

7-1. ENGINEERING SAMPLE FLOW CHART

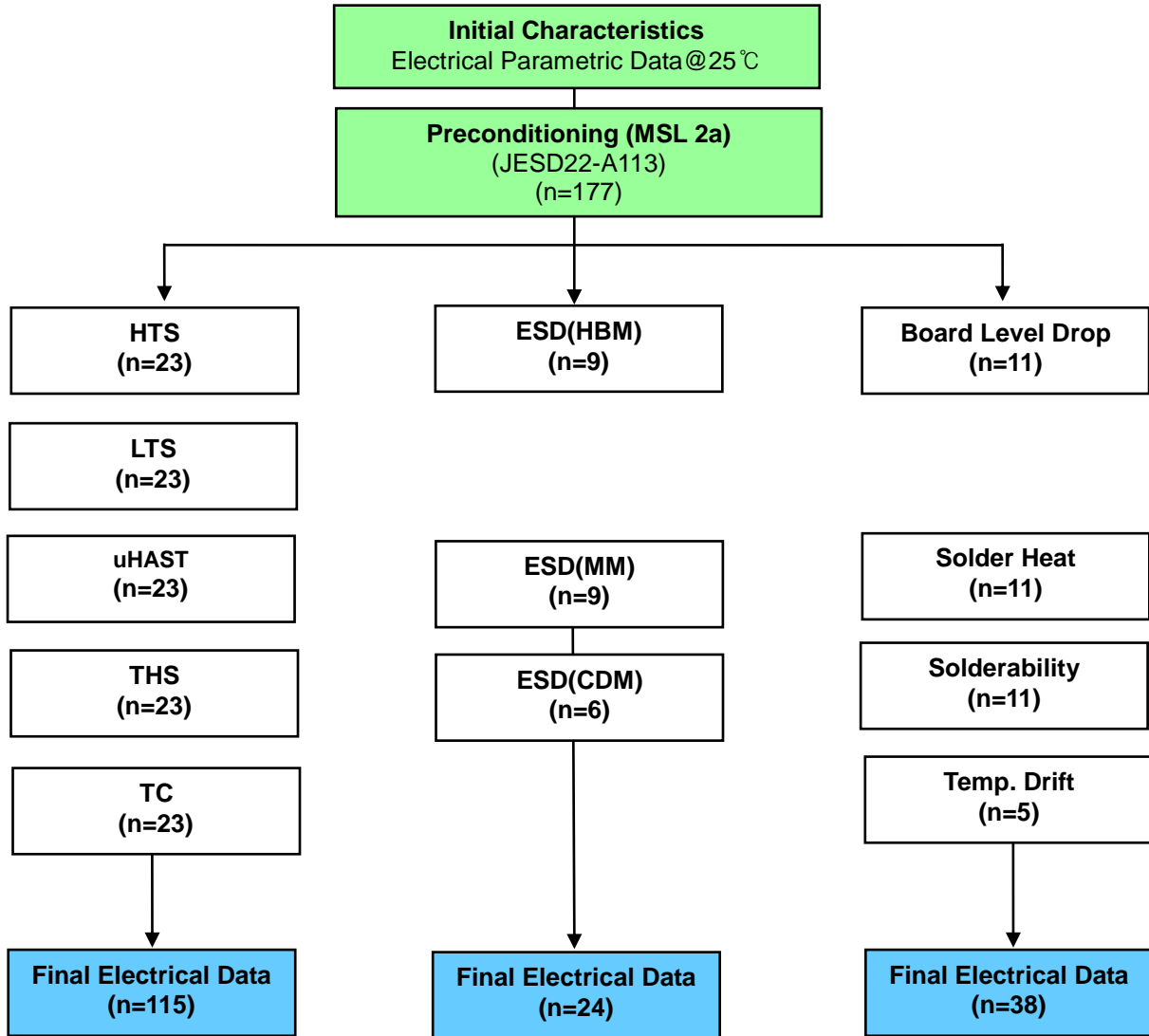

7-2. TEST ITEM & CONDITION

CATEGORY	TEST ITEM	TEST CONDITION	REMARK
	Preconditioning	Bake + Soak(MSL or above) + 3X Reflow duration (Soak 60°C 60% 120HR)	JESD22-A113



TEST ITEM	REMARK	TEST CONDITION	Duration
HTS (High Temperature Storage)	JESD22-A103	condition A 125(-0/+10)°C	1000hr
LTS (Low Temperature Storage)	JESD22-A119	A -40(-10/+0)°C	1000hr
uHAST (Unbiased HAST)	JESD22-A118	130°C /85% /33.3psi	96hr
THS (Temperature Humidity Storage)	JESD22-A101	85°C /85% RH	1000hr
TC (Temperature Cycle)	JESD22-A104	Condition B (-55°C /125°C)	500cycle
ESD(HBM)	JESD22-A114	250V or above	-
ESD(MM)	JESD22-A115	No spec but need data	-
ESD(CDM)	JESD22-C101	1.0KV or above	-
Board Level Drop Test	-	120cm(12times), 152cm(19times) total(31times) Steel floor	
Solder Heat Resistance	JESD22-B106C	260°C / 10sec Solder Pore Dipping	10sec
Solderability	JESD22-B102E	235°C/ 3sec Solder Pore Dipping	3sec
Temp Drift		-40°C → +25°C → +125°C	Per Conditions 2HR

8. REFLOW CONDITION

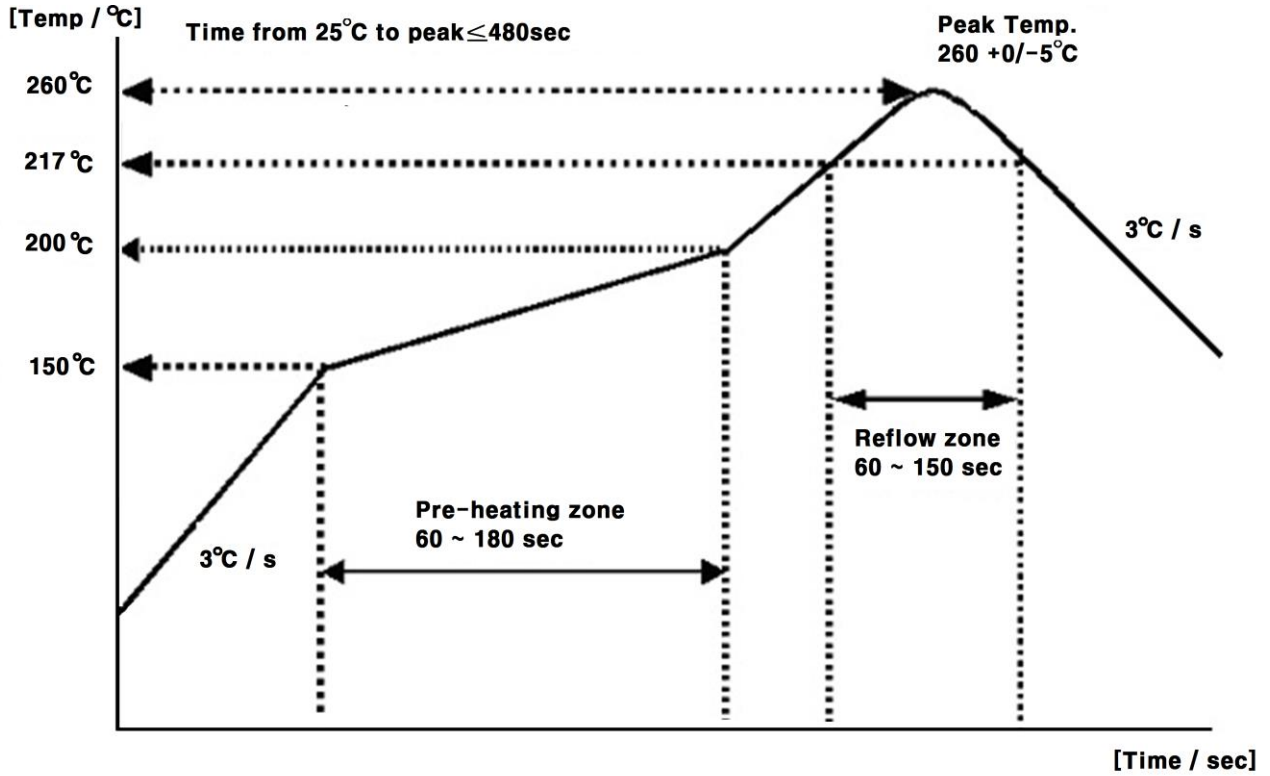

9. RECOMMENDED PCB DIMENSIONS

[unit : mm]

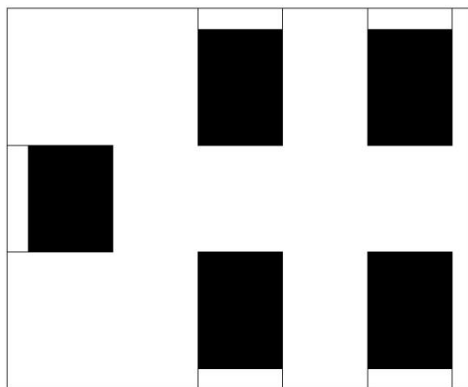

[SAW, X-ray Top view]

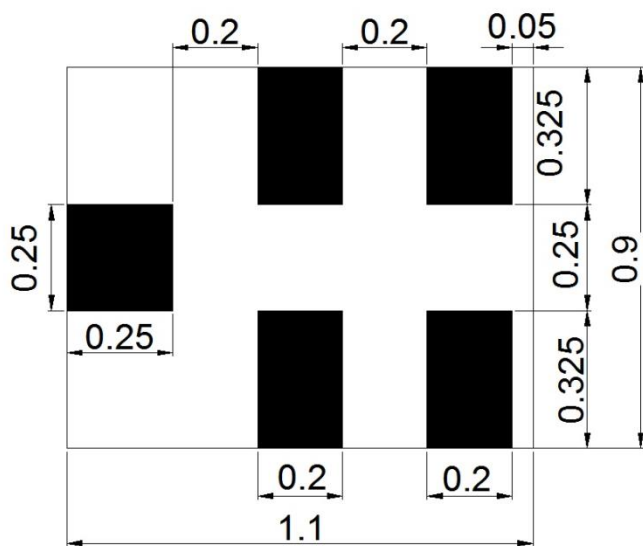

[PCB, X-ray Top view]

10. CAUTION

Moisture Sensitivity Device Caution (MSL LEVEL=2a)

1. Calculated shelf life in sealed bag : 12 month at < 40°C and < 90% relative Humidity(RH)
 2. Peak package body temperature : **260°C**
 3. After bag is opened, devices that will be subjected to reflow solder or other high temperature process must be
 - (a) Mounted within : 672 hours of factory conditions ≤30°C/60% RH, or
 - (b) Stored per J-STD-033
 4. Device require bake, before mounting, if :
 - (a) Humidity Indicator Card reads > 60% when read at 23±5°C
 - (b) 3(a) or 3(b) are not met
 5. If baking is required, refer to IPC/JEDEC J-STD-033 for bake procedure
- Note : Level and body temperature defined by IPC/JEDEC J-STD-020

Aluminum Pack (310mmX370mm)



HIC(Humidity Indication Card)

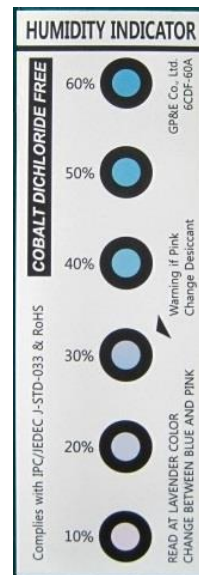

10 to 60% RH

11. PACKING

11-1. DIMENSIONS

- Carrier Tape

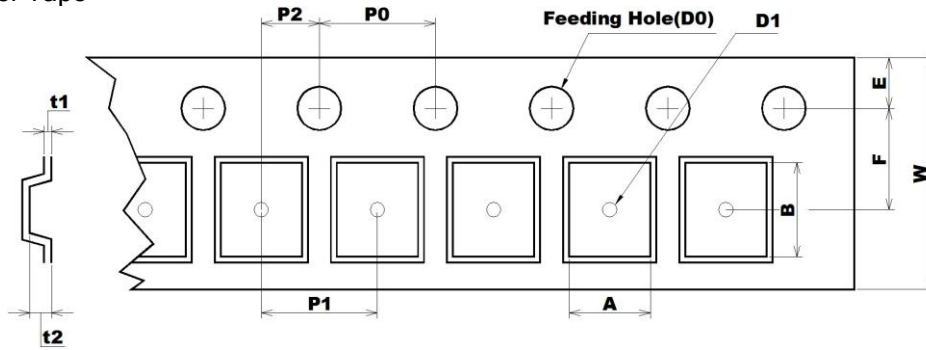

[Unit: mm]

A	B	D0	D1	E	F	P0	P1	P2	t1	t2	W
1.08	1.23	Ø1.50	Ø0.50	1.75	3.50	4.00	4.00	2.00	0.23	0.70	8.00
+0.05	+0.05	+0.10	+0.01	+0.10	+0.05	+0.05	+0.05	+0.05	+0.05	+0.05	+0.30
-0.05	-0.05	-0.00		-0.10	-0.05	-0.05	-0.05	-0.05	-0.05	-0.05	-0.10

- Reel

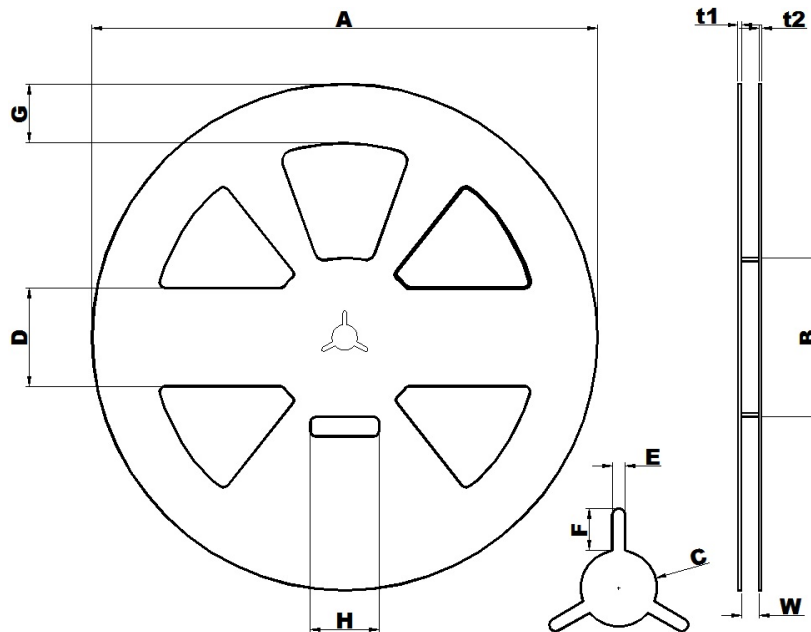

[Unit: mm]

A	B	C	D	E	F	G	H	t1	t2	W
Ø258.0	Ø81.0	Ø13.0	50.0	2.2	7.0	30.0	35.0	1.8	1.5	9.0
+1.0	+1.0	+0.5	+0.8	+0.3	+0.5	+0.8	+1.0	+0.5	+0.5	+1.0
-0.5	-1.0	-0.5	-0.8	-0.3	-0.5	-0.8	-1.0	-0.5	-0.5	-0.5

- The product shall be packed properly not to damaged during transportation and storage.

11-2. REELING QUANTITY

10 inch reel : 10,000 pcs/reel

11-3. TAPING STRUCTURE

11-3-1. The tape shall be wound around the reel in direction shown below.

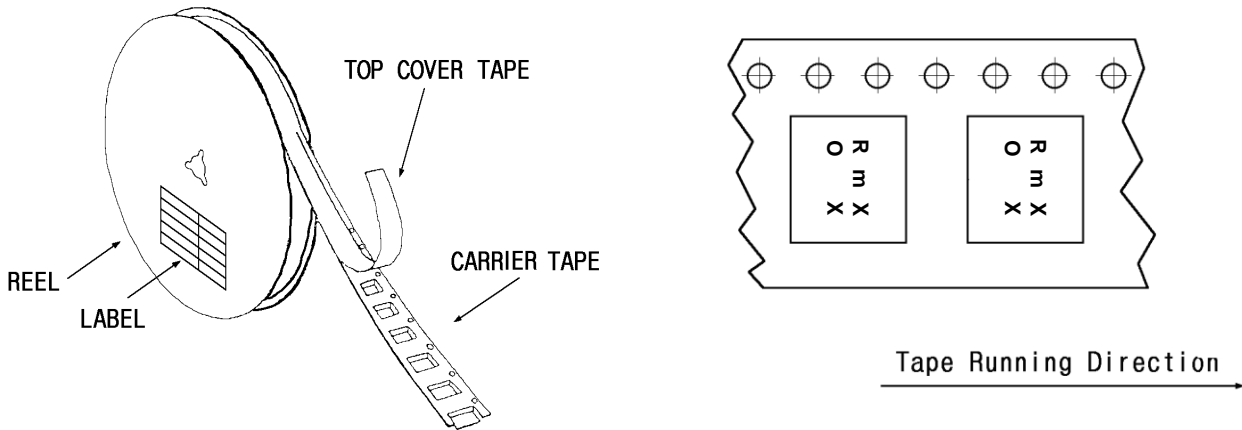

11-3-2. BARCODE LABEL



①	MODEL NAME BARCODE
②	Model Name
③	Reel number
④	Quantity / Marking

1-3-3. Leader part and vacant position specifications.

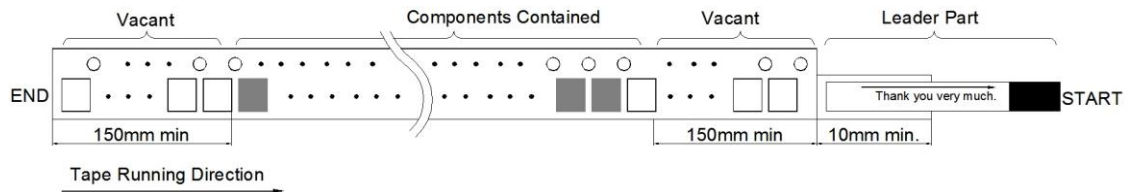

11-4. INNER BOX(Reel Packing) STRUCTURE

Material: Polycarbonate

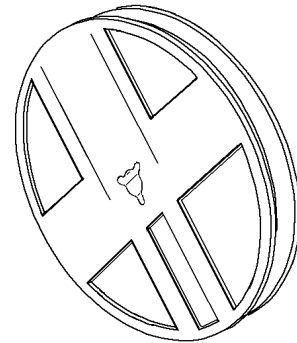

Material : Polyethylene + Aluminium
Size : 310×370mm²

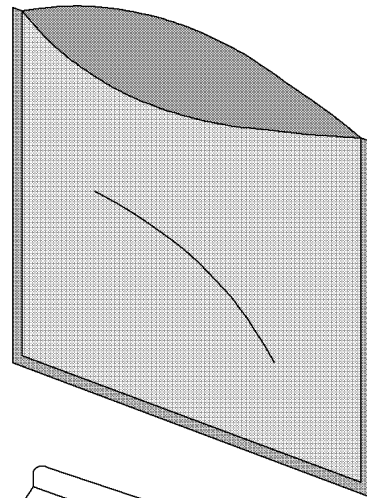

Material : Paper
Size: (D)260×(W)37×(H)265mm³

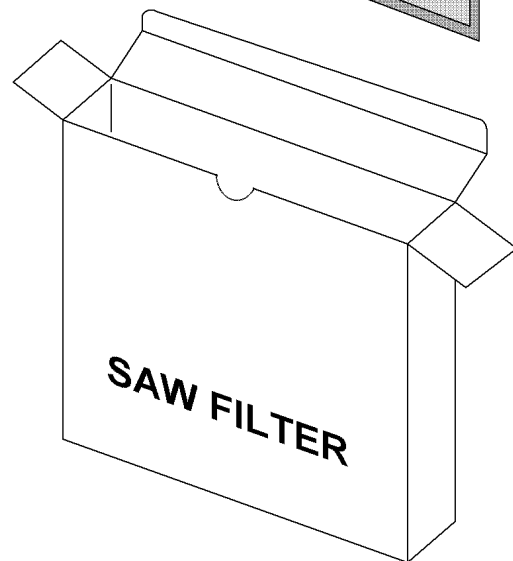

11-5. OUTER BOX STRUCTURE

Material : Paper

TYPE	SIZE(mm)			Inner Box #
	a	b	c	
A	270	240	275	6 boxes

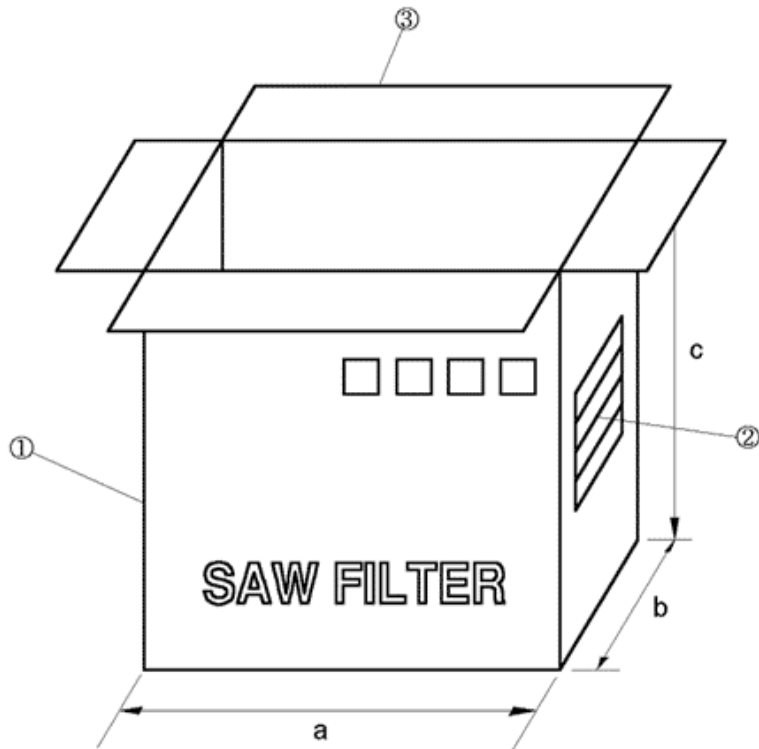

SIDE ①

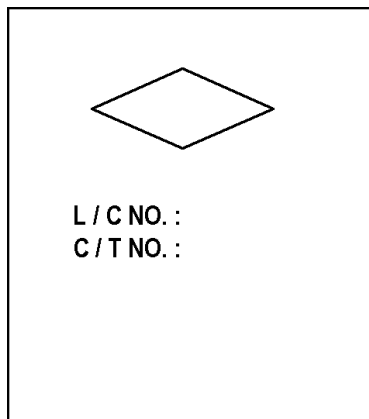

SIDE ②

MODEL	
Q'TY	EA
USER	
DATE	. .

- SIDE is the same as front side.

12. TAPE SPECIFICATIONS

12-1. Tensile Strength of Carrier Tape: 4.4N/mm width

12-2. Top Cover Tape Adhesion (See the below figure)

- pull of angle: 0~15 degree
- speed: 300mm/min.
- force: 20~70g

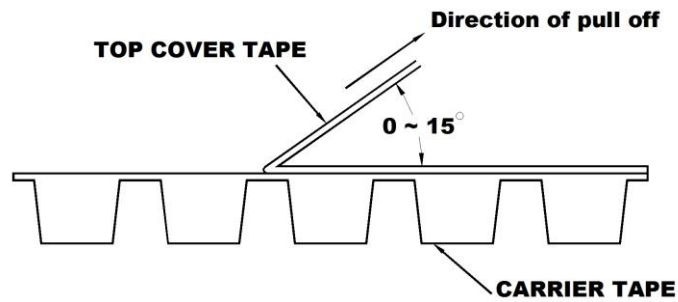

13. RoHS DATA



Test Report No. F690101/LF-CTSAYAA17-25974

Issued Date : 2017. 05. 10

Page 1 of 8

WISOL CO., LTD.
28-40, Gajangsaneopdong-ro
Osan-si, Gyeonggi-do
Korea



The following sample(s) was/were submitted and identified by/on behalf of the client as:-

SGS File No. : AYAA17-25974
Product Name : SAW FILTER
Item No./Part No. : N/A
Buyer(s) : SAMSUNG
Received Date : 2017. 05. 02
Test Period : 2017. 05. 02 to 2017. 05. 10
Test Results : For further details, please refer to following page(s)

SGS Korea Co., Ltd.

Handwritten signature of Jeff Jang

Jeff Jang / Chemical Lab Mgr

This document is the property of SGS Korea Co., Ltd. and is provided to you by the Company subject to its General Conditions of Service printed overleaf, available on request or accessible at http://www.sgs.com/ky/Terms-and-Conditions.aspx...

F401



SGS Korea Co., Ltd.

322, The O valley, 76, LS-ro, Dongen-gu, Anyang-si, Gyeonggi-do, Korea 14117
+82 (0)31 4838 000 +82 (0)31 4838 050 http://www.sgs.com/kr

Member of the SGS Group (Société Générale de Surveillance)



Test Report No. F690101/LF-CTSAAYAA17-25974

Issued Date : 2017. 05. 10

Page 2 of 8

Sample No. : AYAA17-25974.001
 Sample Description : SAW FILTER
 Item No./Part No. : N/A
 Materials : HTCC, GOLD, EPOXY, LT

Heavy Metals

Test Items	Unit	Test Method	MDL	Results
Cadmium (Cd)	mg/kg	With reference to IEC 62321-5:2013 (Determination of Cadmium by ICP-OES)	0.5	N.D.
Lead (Pb)	mg/kg	With reference to IEC 62321-5:2013 (Determination of Lead by ICP-OES)	5	N.D.
Mercury (Hg)	mg/kg	With reference to IEC 62321-4:2013 (Determination of Mercury by ICP-OES)	2	N.D.
Hexavalent Chromium (Cr VI)	mg/kg	With reference to IEC 62321:2008 (Determination of Hexavalent Chromium by spot test/Colorimetric Method using UV-Vis)	1	N.D.
Antimony (Sb)	mg/kg	With reference to EPA 3052(1996), US EPA 6010B(1996), ICP	10	N.D.

Flame Retardants-PBBs/PBDEs

Test Items	Unit	Test Method	MDL	Results
Monobromobiphenyl	mg/kg	With reference to IEC 62321-6:2015 (Determination of PBBs and PBDEs by GC-MS)	5	N.D.
Dibromobiphenyl	mg/kg	With reference to IEC 62321-6:2015 (Determination of PBBs and PBDEs by GC-MS)	5	N.D.
Tribromobiphenyl	mg/kg	With reference to IEC 62321-6:2015 (Determination of PBBs and PBDEs by GC-MS)	5	N.D.
Tetrabromobiphenyl	mg/kg	With reference to IEC 62321-6:2015 (Determination of PBBs and PBDEs by GC-MS)	5	N.D.
Pentabromobiphenyl	mg/kg	With reference to IEC 62321-6:2015 (Determination of PBBs and PBDEs by GC-MS)	5	N.D.
Hexabromobiphenyl	mg/kg	With reference to IEC 62321-6:2015 (Determination of PBBs and PBDEs by GC-MS)	5	N.D.
Heptabromobiphenyl	mg/kg	With reference to IEC 62321-6:2015 (Determination of PBBs and PBDEs by GC-MS)	5	N.D.
Octabromobiphenyl	mg/kg	With reference to IEC 62321-6:2015 (Determination of PBBs and PBDEs by GC-MS)	5	N.D.
Nonabromobiphenyl	mg/kg	With reference to IEC 62321-6:2015 (Determination of PBBs and PBDEs by GC-MS)	5	N.D.
Decabromobiphenyl	mg/kg	With reference to IEC 62321-6:2015 (Determination of PBBs and PBDEs by GC-MS)	5	N.D.
Monobromodiphenyl ether	mg/kg	With reference to IEC 62321-6:2015 (Determination of PBBs and PBDEs by GC-MS)	5	N.D.
Dibromodiphenyl ether	mg/kg	With reference to IEC 62321-6:2015 (Determination of PBBs and PBDEs by GC-MS)	5	N.D.

This document is issued by the Company subject to its General Conditions of Service printed overleaf, available on request or accessible at <http://www.sgs.com/kr/Terms-and-Conditions.aspx> and, for electronic format documents, subject to Terms and Conditions for Electronic Documents at www.sgs.com/terms_e-document.htm and http://www.sgs.com/terms_e-document.htm. Attention is drawn to the limitation of liability, indemnification and jurisdiction issues defined therein. Any holder of this document is advised that information contained herein reflects the Company's findings at the time of its intervention only and within the limits of Client's instructions, if any. The Company's sole responsibility is to its Client and this document does not constitute parties to a transaction from exercising all their rights and obligations under the transaction documents. This document cannot be reproduced except in full, without prior written approval of the Company. Any unauthorized alteration, forgery or falsification of the content or appearance of this document is unlawful and offenders may be prosecuted to the fullest extent of the law. Unless otherwise stated the results shown in this test report refer only to the sample(s).

F401 Version3

SGS Korea Co., Ltd.

322, The G valley, 75, LS-ro, Dongan-gu, Anyang-si, Gyeonggi-do, Korea 14117
 T +82 (0)31 4808 000 F +82 (0)31 4808 059 <http://www.sgs.com/kr>

Member of the SGS Group (Société Générale de Surveillance)



Test Report No. F690101/LF-CTSAYAA17-25974

Issued Date : 2017. 05. 10

Page 3 of 8

Sample No. : AYAA17-25974.001
 Sample Description : SAW FILTER
 Item No./Part No. : N/A
 Materials : HTCC, GOLD, EPOXY, LT

Flame Retardants-PBBs/PBDEs

Test Items	Unit	Test Method	MDL	Results
Tribromodiphenyl ether	mg/kg	With reference to IEC 62321-6:2015 (Determination of PBBs and PBDEs by GC-MS)	5	N.D.
Tetrabromodiphenyl ether	mg/kg	With reference to IEC 62321-6:2015 (Determination of PBBs and PBDEs by GC-MS)	5	N.D.
Pentabromodiphenyl ether	mg/kg	With reference to IEC 62321-6:2015 (Determination of PBBs and PBDEs by GC-MS)	5	N.D.
Hexabromodiphenyl ether	mg/kg	With reference to IEC 62321-6:2015 (Determination of PBBs and PBDEs by GC-MS)	5	N.D.
Heptabromodiphenyl ether	mg/kg	With reference to IEC 62321-6:2015 (Determination of PBBs and PBDEs by GC-MS)	5	N.D.
Octabromodiphenyl ether	mg/kg	With reference to IEC 62321-6:2015 (Determination of PBBs and PBDEs by GC-MS)	5	N.D.
Nonabromodiphenyl ether	mg/kg	With reference to IEC 62321-6:2015 (Determination of PBBs and PBDEs by GC-MS)	5	N.D.
Decabromodiphenyl ether	mg/kg	With reference to IEC 62321-6:2015 (Determination of PBBs and PBDEs by GC-MS)	5	N.D.

Halogen Content

Test Items	Unit	Test Method	MDL	Results
Bromine(Br)	mg/kg	With reference to EN 14582, IC	30	N.D.
Chlorine(Cl)	mg/kg	With reference to EN 14582, IC	30	N.D.

- NOTE: (1) N.D. = Not detected.(<MDL)
 (2) mg/kg = ppm
 (3) MDL = Method Detection Limit
 (4) - = No regulation
 (5) Negative = Undetectable / Positive = Detectable
 (6) ** = Qualitative analysis (No Unit)
 (7) * = a. The sample is positive for CrVI if the CrVI concentration is greater than 0.13 ug/cm2. The sample coating is considered to contain CrVI.
 b. The sample is negative for CrVI if CrVI is n.d. (concentration less than 0.10 ug/cm2). The coating is considered a non-CrVI based coating.
 c. The result between 0.10 ug/cm2 and 0.13 ug/cm2 is considered to be inconclusive - unavoidable coating variations may influence the determination.

This document is issued by the Company subject to its General Conditions of Service printed overleaf, available on request or accessible at <http://www.sgs.com/sgs/Terms-and-Conditions.aspx> and, for electronic format documents, subject to Terms and Conditions for Electronic Documents at www.sgs.com/terms_e-document.htm http://www.sgs.com/terms_e-document.htm. Attention is drawn to the limitation of liability, indemnification and jurisdiction issues defined therein. Any holder of this document is advised that information contained hereon reflects the Company's findings at the time of its intervention only and within the limits of Client's instructions, if any. The Company's sole responsibility is to its Client and this document does not exonerate parties to a transaction from exercising all their rights and obligations under the transaction documents. This document cannot be reproduced except in full, without prior written approval of the Company. Any unauthorized alteration, forgery or falsification of the content or appearance of this document is unlawful and offenders may be prosecuted to the fullest extent of the law. Unless otherwise stated the results shown in this test report refer only to the sample(s).



Test Report No. F690101/LF-CTSAYAA17-25974

Issued Date : 2017. 05. 10

Page 4 of 8

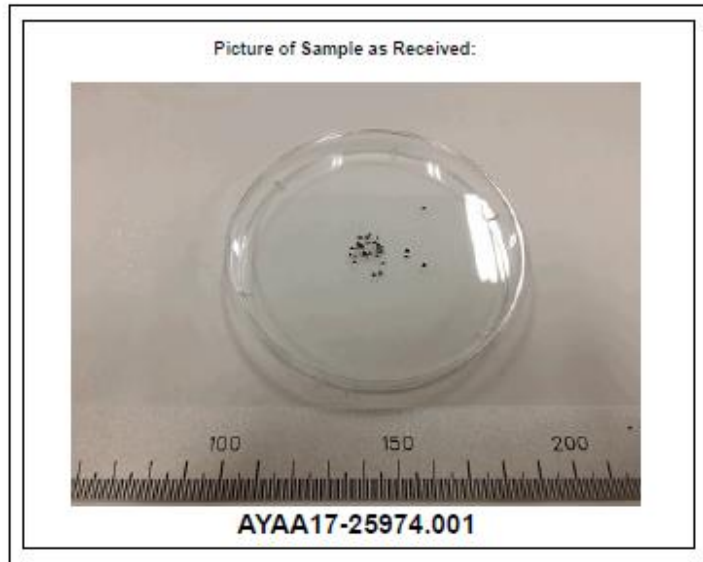

This document is issued by the Company subject to its General Conditions of Service printed overleaf, available on request or accessible at <http://www.sgs.com/ser/Terms-and-Conditions.aspx>, and, for electronic format documents, subject to Terms and Conditions for Electronic Documents at www.sgs.com/terms_e-document.htm - http://www.sgs.com/terms_e-document.htm. Attention is drawn to the limitation of liability, indemnification and jurisdiction issues defined therein. Any holder of this document is advised that information contained herein reflects the Company's findings at the time of its intervention only and within the limits of Client's instructions, if any. The Company's sole responsibility is to its Client and this document does not constitute parties to a transaction from exercising all their rights and obligations under the transaction documents. This document cannot be reproduced except in full, without prior written approval of the Company. Any unauthorized alteration, forgery or falsification of the content or appearance of this document is unlawful and offenders may be prosecuted to the fullest extent of the law. Unless otherwise stated the results shown in this test report refer only to the sample(s).

401 Version3

SGS Korea Co., Ltd

322, The G valley, 76, L5-ro, Dongan-gu, Anyang-si, Gyeonggi-do, Korea 14117
t +82 (0)2 4526 0000 f +82 (0)2 4526 0500 <http://www.sgs.com/kr>

Member of the SGS Group (Société Générale de Surveillance)



Test Report No. F690101/LF-CTSAYAA17-25974

Issued Date : 2017. 05. 10

Page 5 of 8

Testing Flow Chart for RoHS: Cd/Pb/Hg/Cr⁶⁺ /PBBs&PBDEs Testing

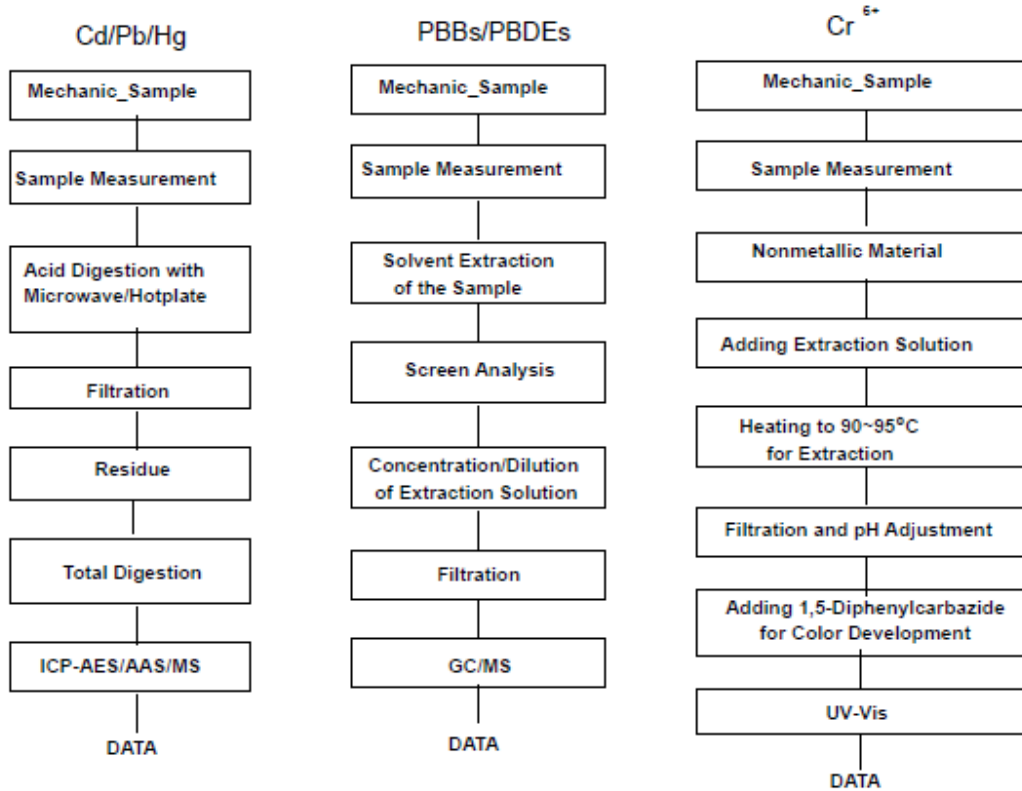

The samples were dissolved totally by pre-conditioning method according to above flow chart for Cd,Pb,Hg.
Section Chief : Gilsae Yi

This document is issued by the Company subject to its General Conditions of Service printed overleaf, available on request or accessible at <http://www.sgs.com/ter/ Terms-and-Conditions.aspx> and, for electronic format documents, subject to Terms and Conditions for Electronic Documents at www.sgs.com/terms_e-document.htm and http://www.sgs.com/terms_e-document.htm. Attention is drawn to the limitation of liability, indemnification and jurisdiction issues defined therein. Any holder of this document is advised that information contained herein reflects the Company's findings at the time of its intervention only and within the limits of Client's instructions, if any. The Company's sole responsibility is to its Client and this document does not constitute parties to a transaction from exercising all their rights and obligations under the transaction documents. This document cannot be reproduced except in full, without prior written approval of the Company. Any unauthorized alteration, forgery or falsification of the content or appearance of this document is unlawful and offenders may be prosecuted to the fullest extent of the law. Unless otherwise stated the results shown in this test report refer only to the sample(s).



Test Report No. F690101/LF-CTSAYAA17-25974

Issued Date : 2017. 05. 10

Page 6 of 8

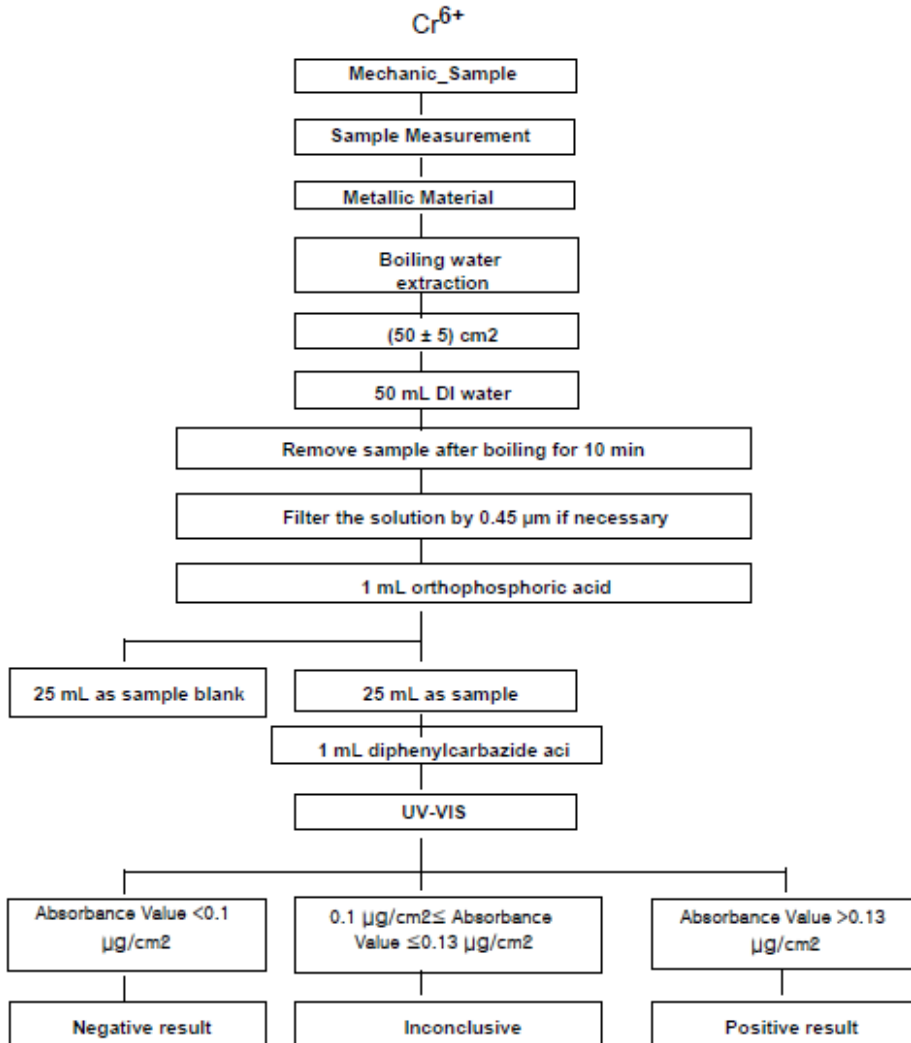

This document is issued by the Company subject to its General Conditions of Service printed overleaf, available on request or accessible at <http://www.sgs.com/sgs/terms-and-conditions.aspx> or, for electronic format documents, subject to Terms and Conditions for Electronic Documents at www.sgs.com/terms_e-document.htm / http://www.sgs.com/terms_e-document.htm. Attention is drawn to the limitation of liability, indemnification and jurisdiction issues defined therein. Any holder of this document is advised that information contained herein reflects the company's findings at the time of its intervention only and within the limits of Client's instructions, if any. The Company's sole responsibility is to its Client and this document does not constitute parties to a transaction from exercising all their rights and obligations under the transaction documents. This document cannot be reproduced except in full, without prior written approval of the Company. Any unauthorized alteration, forgery or falsification of the content or appearance of this document is unlawful and offenders may be prosecuted to the fullest extent of the law. Unless otherwise stated the results shown in this test report refer only to the sample(s).

01 Version3

SGS Korea Co., Ltd

322, The O valley, 76, LS-ro, Dongan-gu, Anyang-si, Gyeonggi-do, Korea 14117
 t +82 (0)31 4838 000 f +82 (0)31 4838 099 <http://www.sgskorea.kr>

Member of the SGS Group (Société Générale de Surveillance)



Flow Chart for Inorganic Elements Testing

Inorganic Elements

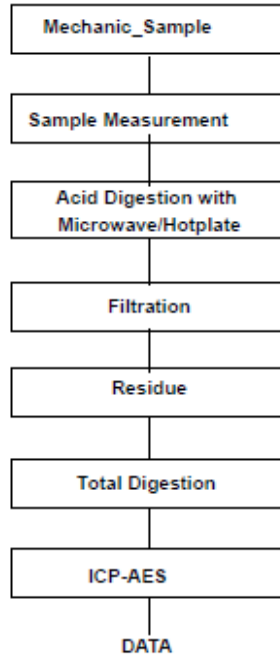

Major Inorganic Heavy Metals	Antimony(Sb) , Beryllium(Be) , Phosphorus(P) , Arsenic(As) etc.
------------------------------	---

This document is issued by the Company subject to its General Conditions of Service printed overleaf, available on request or accessible at <http://www.sgs.com/terms-and-conditions.aspx>, for electronic format documents, subject to Terms and Conditions for Electronic Documents at www.sgs.com/terms-e-document.htm - <http://www.sgs.com/terms-e-document.htm>. Attention is drawn to the limitation of liability, indemnification and jurisdiction issues defined therein. Any holder of this document is advised that information contained herein reflects the company's findings at the time of its intervention only and within the limits of Client's instructions, if any. The Company's sole responsibility is to its Client and this document does not constitute parties to a transaction from exercising all their rights and obligations under the transaction documents. This document cannot be reproduced except in full, without prior written approval of the Company. Any unauthorized alteration, forgery or falsification of the content or appearance of this document is unlawful and offenders may be prosecuted to the fullest extent of the law. Unless otherwise stated the results shown in this test report refer only to the sample(s).

#01 Version3

SGS Korea Co., Ltd. | 322, The G valley, 76, LS-ro, Dongen-gu, Anyang-si, Gyeonggi-do, Korea 14117
 +82 (0)31 4638 000 | +82 (0)31 4638 089 | <http://www.sgs.com.kr>

Member of the SGS Group (Société Générale de Surveillance)