

LEFT SIDE VIEW

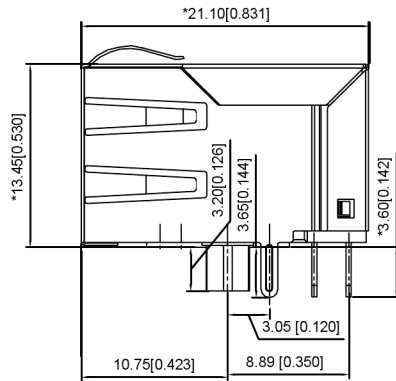

RIGHT SIDE VIEW

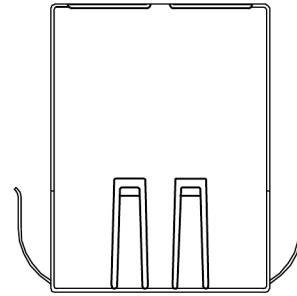

TOP VIEW

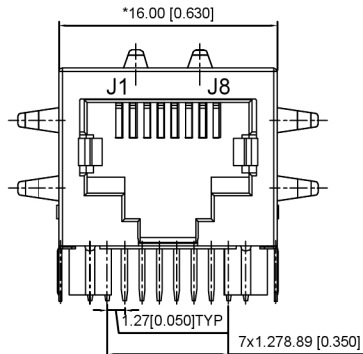

FRONT VIEW

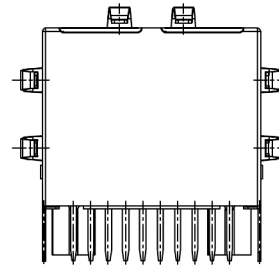

BACK VIEW

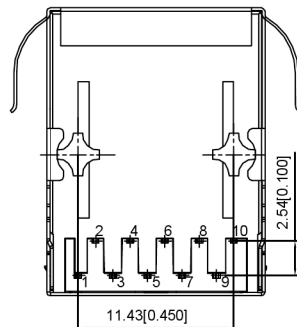

BOTTOM VIEW

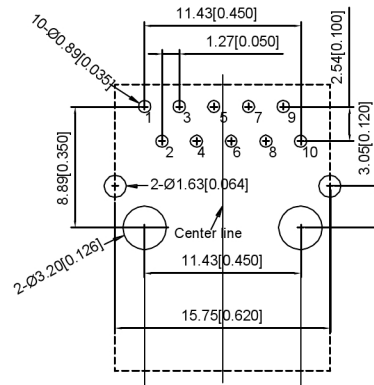

RECOMMENDED PCB LAYOUT VIEWED FROM COMPONENT SIDE

Electrical 电气:

- Turn ratio 匝数比: 1~2: J1~J2=1CT:1CT(±2%)
3~4: J3~J6=1CT:1CT(±2%)
7~8: J4~J5=1CT:1CT(±2%)
9~10: J7~J8=1CT:1CT(±2%)
- OCL: 350uH Min.at 100KHz 100mV 8mA DC.
- Insertion Loss 插入损耗: -1.0 dB Max 1~100MHz.
- Return loss 回程损耗: -20dB Min 1~10MHz
-16dB Min 10~30MHz
-12dB Min 30~60MHz
-10dB Min 60~80MHz
- Cross talk 声道串扰: -40dB Min 1~30MHz;
-35dB Min 30~60MHz;
-30dB Min 60~100MHz;
- CMR 共模抑制: -30dB Min 1~100MHz;
- Hi-Pot 耐压测试: 1500V AC & 2250V DC 6S
1mA PRI TO SEC

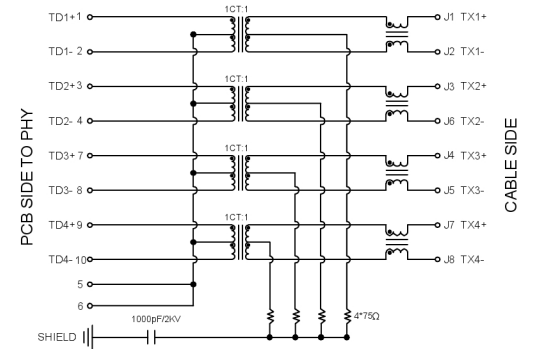

XKB Connectivity

MATERIAL 材料:

HOUSING 外壳: PBT,UL94V-0,BLACK. HF
TERMINALS BRACKET 端子支架: PBT,UL94V-0,BLACK. HF
SHIELD 保护物: C2680,T=0.20MM,NICKEL PLATING ON ALL AREA.
TERMINAL 端子: PHOSPHOR BRONZE C5210,T=0.35MM,
GOLD PLATING ON CONTACT AREA.

MECHANICAL 机械:

DURABILITY 耐用性: 750 CYCLES MIN.
MATING FORCE 配合力: 23N MAX.
OPERATING TEMPERATURE 工作温度: -40°C~+85°C.
STORAGE TEMPERATURE 储存温度: -40°C~+85°C.
ALL CRITICAL DIMENSIONS WITH ""

广东星坤科技股份有限公司

△X		日期
△X		日期
△X		日期
MARK		DESCRIPTION

REVISIONS

www.helloxkb.com www.helloxkb.cn www.xk-dg.cn

ANGLAR	±5°
L ≤ 4	±0.2
4 < L ≤ 16	±0.3
16 < L ≤ 63	±0.4
L > 63	±0.5
UNSPECIFIED TOLERANCES	



DSND		SCALE: N/A	MODEL TYPE: RJ JACK		
DWN		VIEW:	PART NO.:		
CHKD		UNIT: mm/in	DWG NO.:		
APPD		SIZE: A4	X01AQ070HWAD		
		WEIGHT	SHEET	REVISIOI	
			1/1	A0	

XKB INDUSTRIAL PRECISION CO.,LIMITED

文件工程章